



Designated according to The Construction Products (Amendment etc.) (EU Exit) Regulations 2020

UK Technical Assessment	UKTA-0836-22/6337 of 9/11/2022
Technical Assessment Body issuing the UK Technical Assessment:	British Board of Agrément
Trade name of the construction product:	TFIX-8M Insulation Support
Product family to which the construction product belongs:	Area Code 33, Nailed-in plastic anchor for fixing of external thermal insulation composite systems with rendering in concrete and masonry
Manufacturer:	RAWLPLUG S.A. Kwidzynska 6 51-416 WROCLAW POLEN
Manufacturing plant(s):	RAWLPLUG S.A. Kwidzynska 6 51-416 WROCLAW POLEN
This UK Technical Assessment contains:	15 pages including 3 annexes which form an integral part of this assessment
This UK Technical Assessment is issued in accordance with The Construction Products (Amendment etc.) (EU Exit) Regulations 2020 on the basis of:	UKAD 330196-01-0604 <i>Plastic anchors made of virgin or non-virgin material for fixing of external thermal insulation composite systems with rendering</i>

Communication of this UK Technical Assessment, including transmission by electronic means, shall be in full. However, partial reproduction may be made with the written consent of the issuing British Board of Agrément. Any partial reproduction must be identified as such.

1 Technical description of the product

The TFIX 8M Insulation Support is a nailed in anchor which consists of a plastic part manufactured of polypropylene and an accompanying specific nail of galvanised steel. The head of the nail has an additional plastic coating.

The anchor may in addition be combined with the anchor plates KWL 90, KWL 110 and KWL 140.

The description of the product is given in Annex A.

2 Specification of the intended use(s) in accordance with the applicable UK Assessment Document (hereinafter UKAD)

The performances given in Section 3 are only valid if the anchor is used in compliance with the specifications and conditions given in Annex B.

The verifications and assessment methods on which this UK Technical Assessment is based lead to the assumption of a working life of the anchor of at least 25 years. The indications given on the working life cannot be interpreted as a guarantee given by the producer but are to be regarded only as a means for choosing the right products in relation to the expected economically reasonable working life of the works.

3 Performance of the product and references to the methods used for its assessment

3.1 Mechanical resistance and stability (BWR 1)

The essential characteristics regarding mechanical resistance and stability are included under the Basic Works Requirement Safety and accessibility in use.

3.2 Safety in case of fire (BWR 2)

Not relevant.

3.3 Health, hygiene and the environment (BWR 3)

Regarding dangerous substances, there may be additional legislative requirements falling outside of the scope of this document. These requirements must be complied with as appropriate.

3.4 Safety and accessibility in use (BWR 4)

Essential characteristic	Performance
Characteristic resistance	See Annex C 1
Edge distances and spacing	See Annex B 2
Point thermal transmittance	See Annex C 2
Displacements	See Annex C 2

3.5 Protection against noise (BWR 5)

Not relevant.

3.6 Energy economy and heat retention (BWR 6)

Not relevant.

3.7 Sustainable use of natural resources (BWR 7)

No performance assessed.

4 Assessment and verification of constancy of performance (hereinafter AVCP) system applied

4.1 System of assessment and verification of constancy of performance

According to UKAD No. 330196-01-0604 and Annex V of the Construction Products Regulation (Regulation (EU) 305/2011 as brought into UK law and amended, the system of assessment and verification of constancy of performance (AVCP) 2+ applies.

5 Technical details necessary for the implementation of the AVCP system, as provided for in the applicable UKAD

Technical details necessary for the implementation of the AVCP system are laid down in the control plan deposited with the British Board of Agrément and made available to the UK Approved Bodies involved in the conformity attestation process.

5.1 UKCA marking for the product/ system must contain the following information:

- Identification number of the Approved Body
- Name/address of the manufacturer of the product/ system
- Marking with intention of clarification of intended use
- Date of marking
- Number of certificate of constancy of performance
- UKTA number.

On behalf of the British Board of Agrément



Date of Issue: 9 November 2022

Hardy Giesler
Chief Executive Officer



British Board of Agrément,
1st Floor Building 3
Hatters Lane
Croxley Park
Watford
WD18 8YG

ANNEXES

This annex applies to the product described in the main body of the UK Technical Assessment.

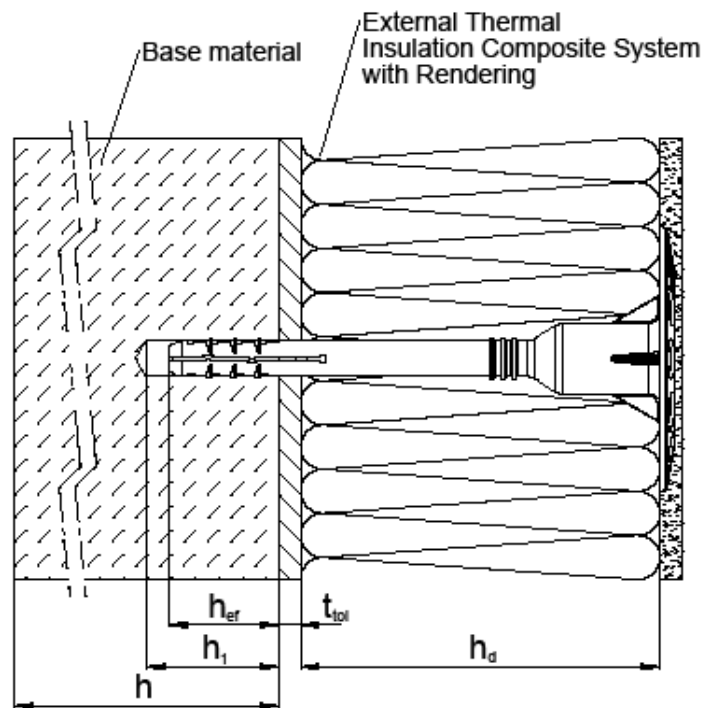

Legend

- h_{ef} = effective anchorage depth
- h = thickness of member (wall)
- h_1 = depth of drilled hole to deepest point
- h_d = thickness of insulation material
- t_{tot} = thickness of equalizing layer or non-load-bearing coating

Insulation support TFIX-8M

Product description
Installed condition

Annex A 1

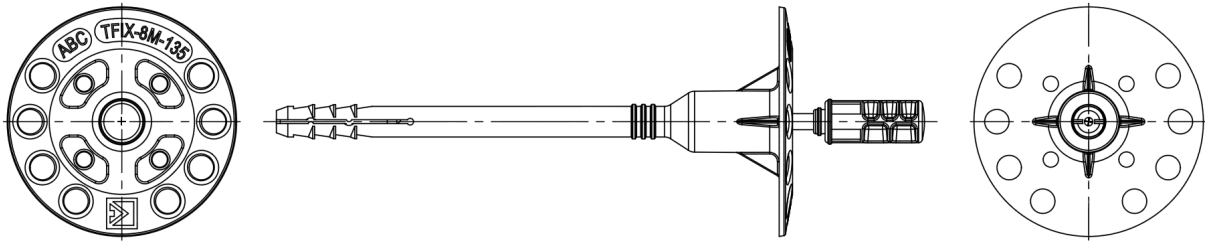

Marking identifying: mark of plant
 Anchor type (TFIX-8M)
 Length of anchor (z.B. 135)

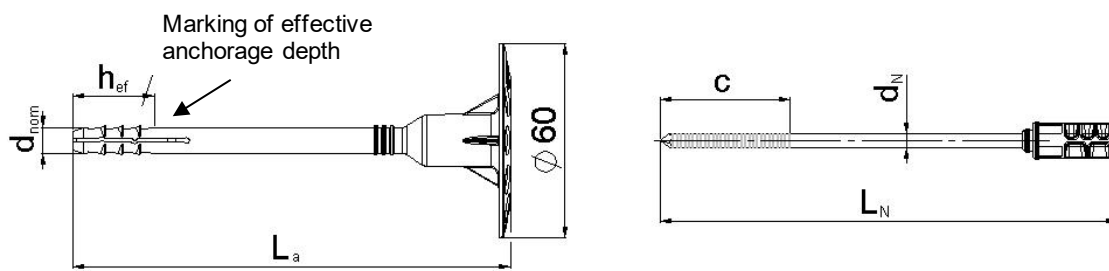

Insulation support TFIX-8M

Product description
 Anchor sleeve and expansion element

Annex A 2

Table A1: Dimension [mm]

Anchor type	Anchor sleeve		Accompanying expansion nail	
	d_{nom}	h_{ef}	d_N	c
TFIX-8M	8	25	4.2	45

Various lengths of the anchor are permissible:

$$L_{a \min} = 75\text{mm}; L_{a \max} = 295\text{mm}$$

Determination of max. thickness of insulation:

$$h_d = L_a - t_{tol} - h_{ef}$$

$$\text{e.g. } L_a = 135\text{mm}$$

$$t_{tol} = 10\text{mm}$$

$$h_d = 135\text{mm} - 10\text{mm} - 25\text{mm}$$

$$h_d = 100\text{mm}$$

Table A2: Materials

Name	Materials
Anchor sleeve	Polypropylene Colour natural
Expansion nail	Steel $\geq 5\mu\text{m}$ according to EN ISO 4042:2018 Head of nail: Coating of polyamide with glass fiber reinforced, colour natural

Insulation support TFIX-8M

Product description
Dimension, materials

Annex A 3

KWL - 90

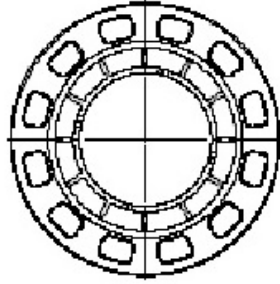

KWL - 110

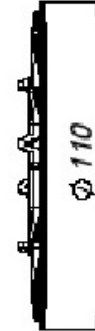
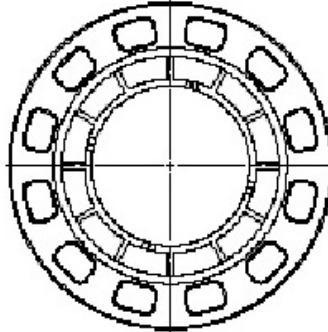

KWL - 140

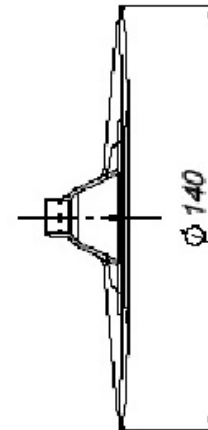
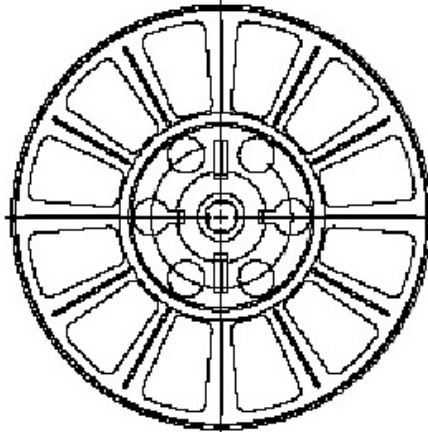

Table A3: Additional plates, diameter and materials

Plate	Diameter	Colour	Materials
KWL-90	90	nature	PA6 + GF, PP
KWL-110	110	nature	
KWL-140	140	nature	

Insulation support TFIX-8M

Product description
Slip-on plates combined with TFIX-8M

Annex A 4

Specifications of intended use

Anchorage subject to:

- The anchor may only be used for transmission of wind suction loads and shall not be used for the transmission of dead loads of the thermal insulation composite system.

Base materials:

- Normal weight concrete (use category A) according to Annex C 1.
- Solid masonry (use category B), according to Annex C 1.
- Hollow or perforated masonry (use category C), according to Annex C 1.
- For other base materials of the use categories B or C the characteristic resistance of the anchor may be determined by on-site tests according to EOTA TR051.

Temperature Range:

- 0°C to +40°C (max. short term temperature +40°C and max. long term temperature +24°C)

Design:

- The anchorages are designed in accordance with the UKAD 330-196-00-0604 under the responsibility of an engineer experienced in anchorages and masonry work.
- Verifiable calculation notes and drawings are prepared taking account of the loads to be anchored. The position of the anchor is indicated on the design drawings.
- Fasteners are only to be used for multiple fixings of thermal insulation composite systems.

Installation:

- Hole drilling by the drill modes according to Annex B.3
- Anchor installation carried out by appropriately qualified personnel and under the supervision of the person responsible for technical matters of the site.
- Installation temperature from 0°C to +40°C
- Exposure to UV due to solar radiation of the anchor not protected by rendering ≤ 6 weeks

Insulation support TFIX-8M	Annex B 1
Intended use Specifications	

Table B1: Installation parameters

Anchor type		TFIX-8M
Drill hole diameter	$d_o = [\text{mm}]$	8
Cutting diameter of drill bit	$d_{cut} < [\text{mm}]$	8.45
Depth of drilled hole to deepest point	$h_1 > [\text{mm}]$	35
Effective anchorage depth	$h_{ef} \geq [\text{mm}]$	25

Table B2: Anchor distances and dimensions of members

Anchor type		TFIX-8M
Minimum spacing	$s_{min} = [\text{mm}]$	100
Minimum edge distance	$c_{min} = [\text{mm}]$	100
Minimum thickness of member	$h = [\text{mm}]$	100

Scheme of distances and spacing

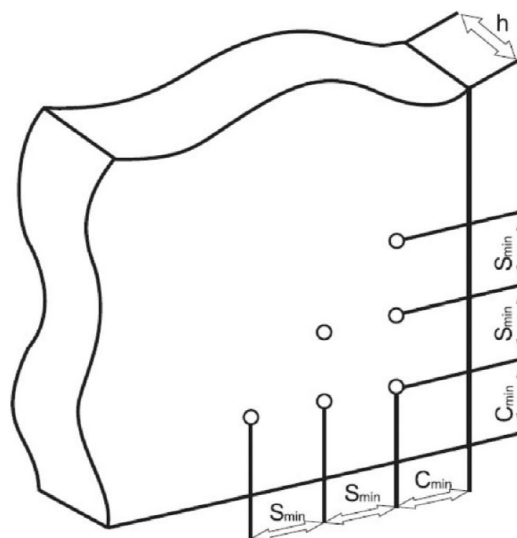

Insulation support TFIX-8M

Intended use
Installation parameters, Edge distances and spacing

Annex B 2

Installation instructions

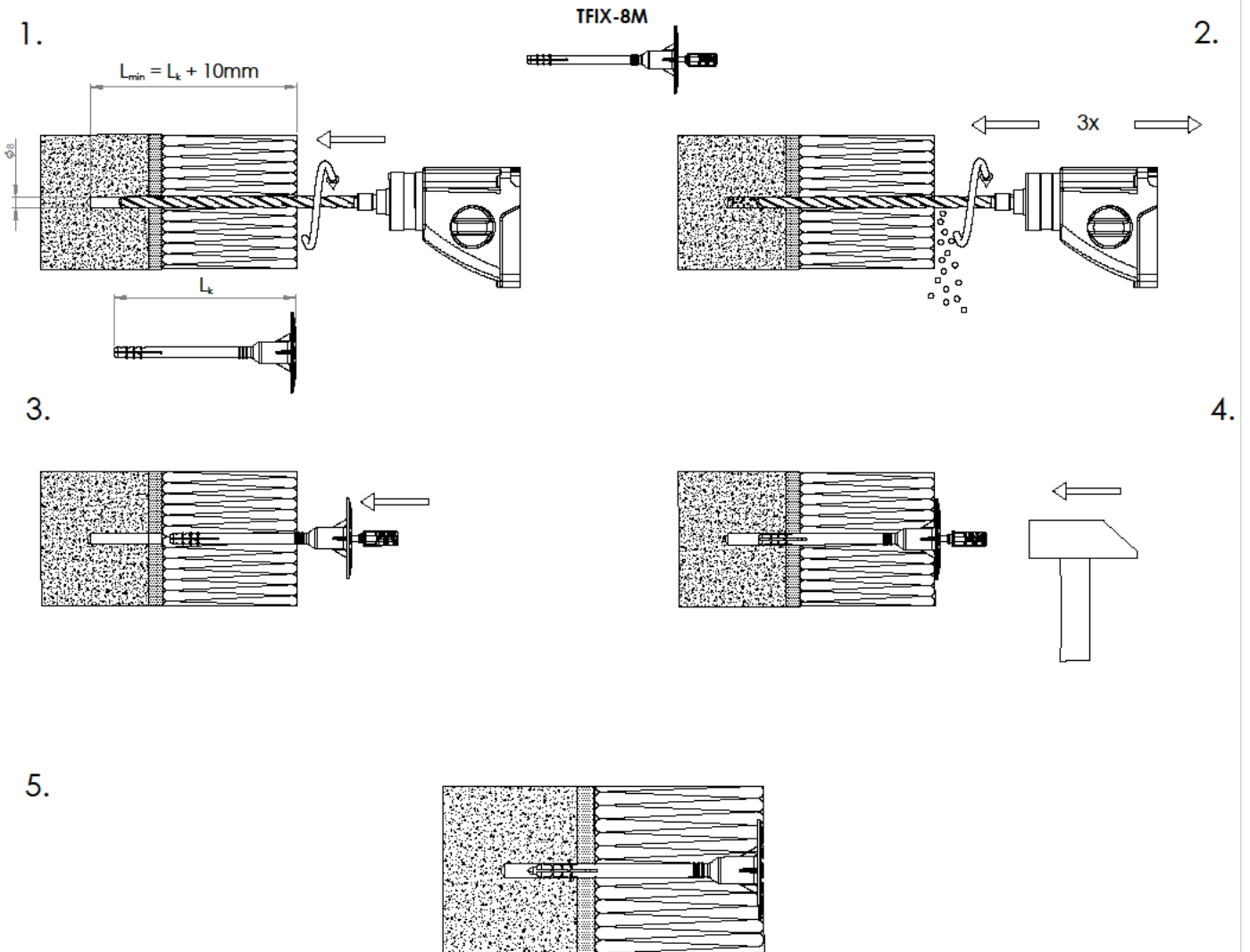

- 1) Drill hole perpendicular to the substrate surface
- 2) Clean the drill hole 3x
- 3) Put TFIX-8M into hole
- 4) Drive in the anchor with the hammer
- 5) The bottom side of the plate must be flush with the ETICS
Installed condition of the TFIX-8M

Insulation support TFIX-8M

Intended use
Installation instructions

Annex B 3

Table C1: Characteristic resistance to tension loads N_{Rk} [kN] in concrete and masonry for single anchor

Anchor type					TFIX-8M
Base material	Bulk density class ρ [kg/dm ³]	Minimum compressive strength f_b [N/mm ²]	General remarks	Drilling method ⁽³⁾	N_{Rk} [kN]
Concrete C12/15 – C50/60 EN 206:2013				H	1.2
Clay brick, Mz e.g. according to EN 771-1: 2011	≥ 2.0	12	Vertical perforation up to 15%	H	1.2
Sand-lime solid bricks (calcium silicate), KS e.g. according to EN 771-2:2011	≥ 1.8	12	Vertical perforation up to 15%	H	1.2
Sand-lime solid bricks (calcium silicate), KSL e.g. according to EN 771-2:2011	≥ 1.6	12	Vertical perforation up to 15%, with outer web thickness of ≥ 20 mm	H	0.9
Perforated clay bricks, HLZ e.g. according to EN 771-1: 2011	≥ 1.0	12	Vertical perforation more than 15%, and less than 50% ⁽¹⁾	D	0.6
Lightweight concrete solid block, Vbl e.g. according to EN 771-3:2011	≥ 0.7	4	Proportion of handle hole to resting area up to 10%, maximum size of handle hole: 110x45mm	D	0.3
Lightweight concrete hollow block, Hbl, e.g., according to EN 771-3:2011	≥ 0.9	2	According to annex C 3 ⁽²⁾	D	0.5
Lightweight concrete solid brick, V e.g., according to EN 771-3:2011	≥ 1.2	6	Proportion of handle hole to resting area up to 10%, maximum size of handle hole: 110x45mm	H	0.5
Partial safety factor ⁽⁴⁾					2.0

- (1) With outer web thickness ≥ 14 mm
 (2) Exterior web thickness ≥ 35 mm
 (3) H = hammer drill, D = rotary drill
 (4) In absence of national regulations

Insulation support TFIX-8M

Performances
 Characteristic bending resistance of the anchor

Annex C 1

Table C2: Point thermal transmittance according EOTA Technical Report TR 025:2007-06

Anchor type	Insulation thickness h_d [mm]	Point thermal transmittance χ [W/K]
TFIX-8M	50 – 270	0.002

Table C3: Plate stiffness according EOTA TR 026:2007-06

Anchor type	Diameter of the anchor plate [mm]	Load resistance of the anchor plate [kN]	Plate stiffness [kN/mm]
TFIX-8M	60	1.75	1.0

Table C4: Displacements

Anchor type	Bulk density class ρ [kg/dm ³]	Minimum compressive strength f_b [N/mm ²]	Tension load N [kN]	Displacements $\delta_m(N)$ [mm]
Concrete C12/15 - C50/60 EN 206:2013			0.40	0.5
Clay brick, Mz e.g. according to EN 771-1: 2011	≥ 2.0	12	0.40	0.7
Sand-lime solid bricks (calcium silikate), KS e.g. according to EN 771-2:2011	≥ 1.8	12	0.40	0.8
Sand-lime solid bricks (calcium silikate), KSL e.g. according to EN 771-2:2011	≥ 1.4	12	0.30	0.4
Perforated clay bricks, HLz e.g. according to EN 771-1: 2011	≥ 1.0	12	0.20	0.6
Lightweight concrete solid block, Vbl e.g. according to EN 771-3:2011	≥ 0.7	4	0.10	0.2
Lightweight concrete hollow block, Hbl, e.g. according to EN 771-3:2011	≥ 0.9	2	0.15	0.3
Lightweight concrete solid brick, V e.g. according to EN 771-3:2011	≥ 1.2	6	0.15	0.3

Insulation support TFIX-8M

Performances

Point thermal transmittance, plate stiffness and displacements, displacements

Annex C 2

Table C5: Assignment type of anchor and geometry of bricks for lightweight-concrete hollow blocks

The anchor shall be placed in a way that spreading part is anchored in the web of the brick

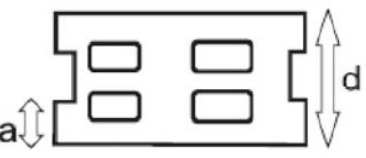
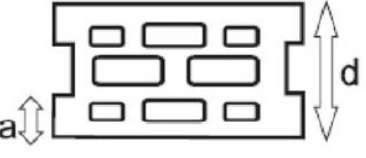
Geometry	Thickness of bricks d [mm]	Outer web in longitudinal direction a [mm]
	175	50
	240 300	50
	365	35
	240 300 365	35
	240 300 365	35

Insulation support TFIX-8M

Intended use
Geometry and dimensions of hollow or perforated brick

Annex C 3

FINAL ACCEPTED DRAFT



British Board of Agrément,
1st Floor Building 3
Hatters Lane
Croxley Park
Watford
WD18 8YG