

LOADS

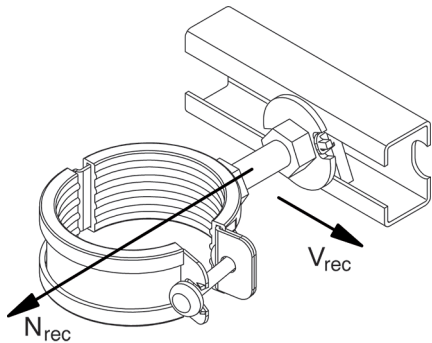

Item	Art.-No.	max. recommended tension load for MS 38/40	max. recommended tension load for MS 40/60	max. recommended shear load	Tightening torque
		N_{rec} [kN]	N_{rec} [kN]	V_{rec} [kN]	T_{inst} [Nm]
FHS CLIX S 8 x 30	020914	5.0	6.5	1.0	5
FHS CLIX S 8 x 40	020915	5.0	6.5	1.0	5
FHS CLIX S 8 x 60	020916	5.0	6.5	1.0	5
FHS CLIX S 10 x 30	020917	5.0	7.5	1.2	10
FHS CLIX S 10 x 40	020918	5.0	7.5	1.2	10
FHS CLIX S 10 x 60	020919	5.0	7.5	1.2	10
FHS CLIX S 12 x 30	020969	5.0	8.5	1.5	10
FHS CLIX S 12 x 40	047316	5.0	8.5	1.5	10
FHS CLIX S 12 x 60	504320	5.0	8.5	1.5	10