



DECLARATION OF PERFORMANCE



DoP: 0131

for fischer TERMOZ 8 SV (Plastic anchors for use in concrete and masonry) – EN

1. Unique identification code of the product-type: **DoP: 0131**
2. Intended use/es: **For use in external thermal insulation composite systems (ETICS) with rendering for the transmission of wind suction loads, see appendix, especially Annexes B 1 to B 3**
3. Manufacturer: **fischerwerke GmbH & Co. KG, Klaus-Fischer-Straße 1, 72178 Waldachtal, Germany**
4. Authorised representative: --
5. System/s of AVCP: **2+**
6. European Assessment Document: **EAD 330196-01-0604**
European Technical Assessment: **ETA-06/0180; 2017-12-04**
Technical Assessment Body: **DIBt**
Notified body/ies: **1343 – MPA Darmstadt**
7. Declared performance/s:

Safety and accessibility (BWR 4)

- **Characteristic resistance :See appendix, especially Annex C 1**
- **Edge distances and spacing: See appendix, especially Annex B 2**
- **Plate stiffness: See appendix, especially Annex C 2**
- **Displacements: See appendix, especially Annex C 2**

Energy economy and heat retention (BWR 6)

- **Point thermal transmittance: See appendix, especially Annex C 2**

8. Appropriate Technical Documentation and/or Specific Technical Documentation: ---

The performance of the product identified above is in conformity with the set of declared performance/s. This declaration of performance is issued, in accordance with Regulation (EU) No 305/2011, under the sole responsibility of the manufacturer identified above.

Signed for and on behalf of the manufacturer by:

Andreas Bucher, Dipl.-Ing.

Wolfgang Hengesbach, Dipl.-Ing., Dipl.-Wirtsch.-Ing.

Tumlingen, 2017-12-11

- This DoP has been prepared in different languages. In case there is a dispute on the interpretation the english version shall always prevail.
- The Appendix includes voluntary and complementary information in English language exceeding the (language-neutrally specified) legal requirements.

Specific Part

1 Technical description of the product

The fischer screwed-in anchor TERMOZ 8 SV consists of a two part anchor sleeve made of polyamide (virgin material), an accompanying specific screw of galvanised steel or of galvanised steel with an additional Duplex-coating or of stainless steel and an accompanying insulation cover.

The serrated expanding part of the anchor sleeve is slotted.

The product description is given in Annex A.

2 Specification of the intended use in accordance with the applicable European Assessment Document

The performances given in Section 3 are only valid if the anchor is used in compliance with the specifications and conditions given in Annex B.

The verification and assessment methods on which this European Technical Assessment is based lead to the assumption of a working life of the anchor of at least 25 years. The indications given on the working life cannot be interpreted as a guarantee given by the producer, but are to be regarded only as a means for choosing the right products in relation to the expected economically reasonable working life of the works.

3 Performance of the product and references to the methods used for its assessment

3.1 Safety and accessibility in use (BWR 4)

Essential characteristic	Performance
Characteristic tension resistance	See Annex C 1
Edge distances and spacing	See Annex B 2
Plate stiffness	See Annex C 2
Displacements	See Annex C 2

3.2 Energy economy and heat retention (BWR 6)

Essential characteristic	Performance
Point thermal transmittance	See Annex C 2

4 Assessment and verification of constancy of performance (AVCP) system applied, with reference to its legal base

In accordance with EAD No.330196-01-0604, the applicable European legal act is: [97/463/EC].

The system to be applied is: 2+

TERMOZ 8 SV

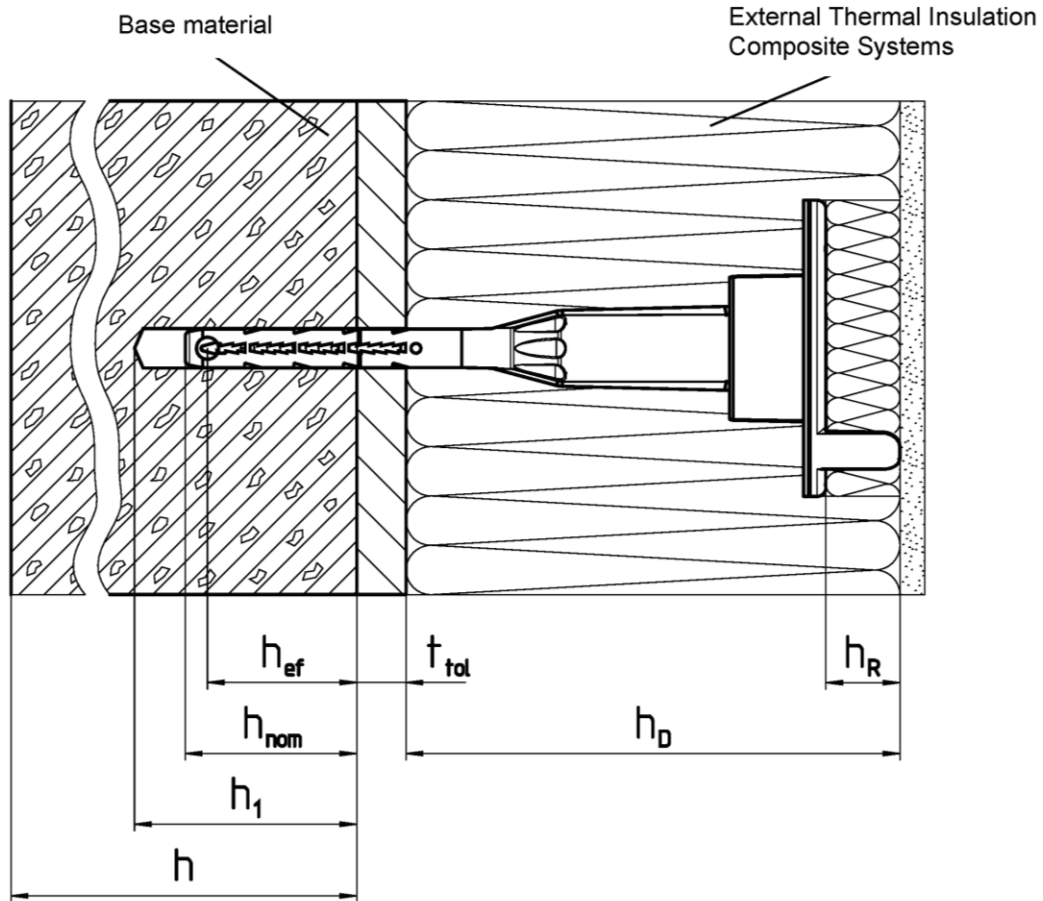

Legend

- h_{ef} = Effective anchorage depth
- h_{nom} = Overall embedment depth
- h_1 = Depth of drill hole in base material
- h = Thickness of base material
- h_D = Thickness of insulation material
- t_{tol} = Thickness of equalizing layer or non-load bearing coating
- h_R = Thickness of insulation cover

fischer screwed-in anchor TERMOZ 8 SV

Product description
Installed anchor

Annex A1

TERMOZ 8 SV

Screw

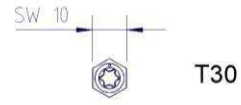
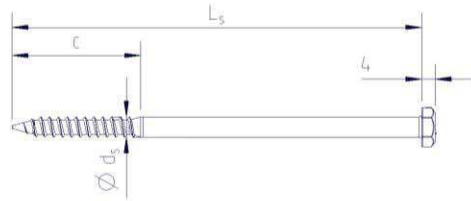
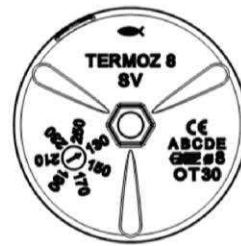
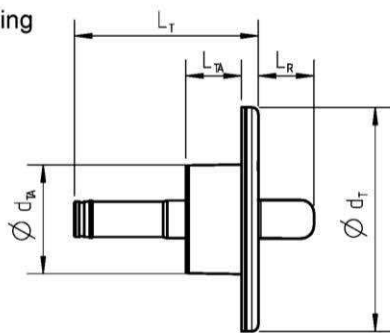
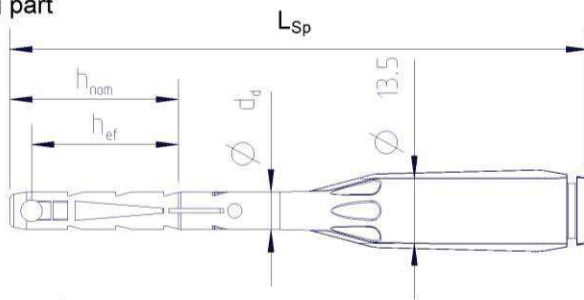

Plate and Marking



Expanding part



Assembling part

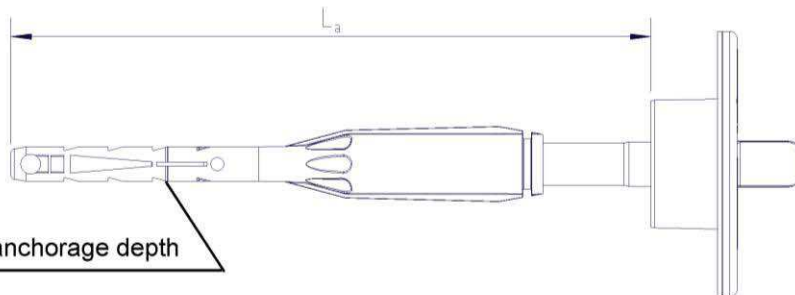

Insulation cover

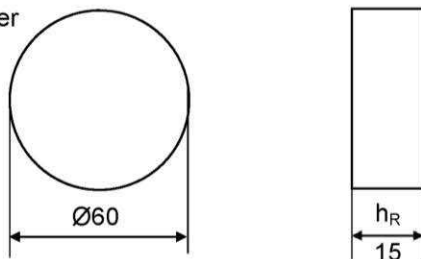

fischer screwed-in anchor TERMOZ 8 SV

Product description
Anchor type and parts

Annex A2

Table A3.1 : Anchor type, parts and dimensions [mm]

Anchor Type	Expanding part		Screw			Plate part				
	\varnothing_{d_d}	L_{Sp}	L_S	d_S	c	L_T	L_R	\varnothing_{d_T}	$\varnothing_{d_{TA}}$	L_{TA}
TERMOZ 8 SV x 130	8	120	120	6	40	64,5	15	60	30	15
TERMOZ 8 SV x 150			140			84,5				
TERMOZ 8 SV x 170			160			104,5				
TERMOZ 8 SV x 190			180			124,5				
TERMOZ 8 SV x 210			200			144,5				
TERMOZ 8 SV x 230			220			164,5				
TERMOZ 8 SV x 250			240			184,5				

$$h_D = L_a - t_{tol} - h_{nom}$$

$$L_a = L_S + 25 \text{ mm}$$

Table A3.2: Materials

Name	Material
Expanding part	Polyamide 6 (virgin material); colour grey
Plate part	Polyamide 6 (virgin material), GF; colour grey
Insulation cover	Polystyrol PS ≥ 15 Mineral wool Type HD
Screw	<ul style="list-style-type: none"> - Steel ($f_{uk} \geq 420 \text{ N/mm}^2$; $f_{yk} \geq 520 \text{ N/mm}^2$) gvz A2F acc. to EN ISO 4042:1999 <li style="text-align: center;">or - Steel gvz A2F acc. to EN ISO 4042:1999 + Duplex-coating type Delta-Seal in three layers (overall thickness $\geq 6\mu\text{m}$) <li style="text-align: center;">or - Stainless steel material No. 1.4401 or 1.4571 ($f_{uk} \geq 700 \text{ N/mm}^2$; $f_{yk} \geq 350 \text{ N/mm}^2$)

fischer screwed-in anchor TERMOZ 8 SV

Product description

Anchor types, dimensions and material

Annex A3

Specifications of intended use

Anchorage subject to:

- The anchor may only be used for transmission of wind suction loads and shall not be used for the transmission of dead loads of the external thermal insulation composite system (ETICS).

Base materials:

- Normal weight concrete (use category A), according to Annex C1.
- Solid masonry (use category B), according to Annex C1.
- Hollow or perforated masonry (use category C), according to Annex C1.
- Lightweight aggregate concrete (use category D), according to Annex C1.
- Autoclaved aerated concrete (use category E), according to Annex C1.
- For other base materials of the use categories A, B, C, D and E the characteristic resistance of the anchor may be determined by job site tests acc. to EOTA Technical Report TR 051 Edition December 2016.

Temperature Range:

- 0°C to +40°C (max. short term temperature +40°C and max. long term temperature +24°C).

Design:

- The anchorages are designed under the responsibility of an engineer experienced in anchorages and masonry work with the partial safety factors $\gamma_M = 2,0$ and $\gamma_F = 1,5$ in absence of other national regulations.
- Verifiable calculation notes and drawings are prepared taking account of the loads to be anchored. The position of the anchors is indicated on the design drawings.
- Fasteners are only to be used for multiple fixings of ETICS.

Installation:

- Drillmethod according to Annex C1.
- Anchor installation carried out by appropriately qualified personnel and under the supervision of the person responsible for technical matters on the site.
- Installation temperature from 0°C to +40°C
- Exposure to UV due to solar radiation of the anchor not protected by rendering ≤ 6 weeks.

<p>fischer screwed-in anchor TERMOZ 8 SV</p>	
<p>Intended use Specification</p>	<p>Annex B1</p>

Table B2.1: Installation parameters

Drill hole diameter	d_0	=	[mm] 8
Cutting diameter of drill bit	d_{cut}	≤	[mm] 8,45
Depth of drill hole	h_1	≥	[mm] 45
Effective anchorage depth	h_{ef}	≥	[mm] 30
Nominal anchorage depth	h_{nom}	≥	[mm] 35

Table B2.2: Minimum distances and spacing

Minimum thickness of member	h	=	[mm] 100
Minimum spacing	s_{min}	=	[mm] 100
Minimum edge distance	c_{min}	=	[mm] 100

Scheme of distance and spacing

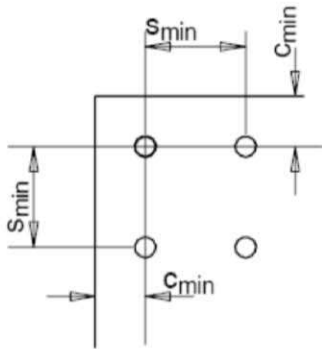

fischer screwed-in anchor TERMOZ 8 SV

Intended use
 Installation parameters
 Minimum distances and spacing

Annex B2

Installation instructions

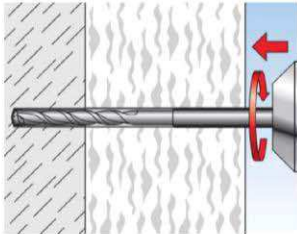

1. Drill the bore hole acc. to Table B2.1 using the drill method described in the corresponding Annex C1.

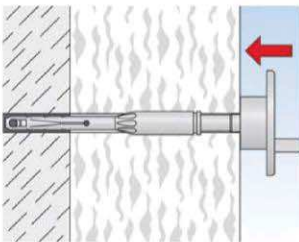

2. Insert anchor manually. Setting is finished when the surface of the ring is flush with the surface of the insulation material.

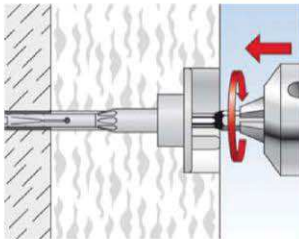

3. Set anchor by screwdriver with the correct bit until the plastic element at the plate part is flat with the insulation surface.

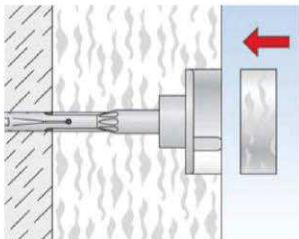

4. Put on polystyrene or mineral wool cap.

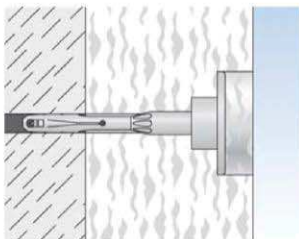

5. Correctly installed anchor.

fischer screwed-in anchor TERMOZ 8 SV

Intended use
Installation instructions

Annex B3

Table C1.1: Characteristic resistance N_{Rk} in [kN] to tension load for a single anchor

Base material	Use cat. ¹⁾	Bulk density [kg/dm ³]	Min. compressive strength β [N/mm ²]	Remarks	Drill method ²⁾	N_{Rk} [kN]
Normal weight concrete C12/15 - C50/60 acc. to EN 206-1:2000	A	-	-	-	H	1,5
Solid clay bricks, acc. to EN 771-1:2011, Mz	B	$\geq 2,0$	12	Cross section reduced up to 15 % perforation vertically to the resting area	H	1,5
Calcium silicate solid bricks, acc. to EN 771-2:2011, KS	B	$\geq 1,8$	12	Cross section reduced up to 15 % perforation vertically to the resting area	H	1,5
Lightweight concrete solid blocks, acc. to EN 771-3:2011, Vbl	B	$\geq 0,7$	4	Cross section reduced up to 15% by perforation vertically to the resting area	R	0,3
Hollow calcium silicate brick, acc. to EN 771-2:2011, KSL	C	$\geq 1,4$	12	Cross section reduced more than 15% and less than 50% by perforation vertically to the resting area. Exterior web thickness ≥ 24 mm	H	1,5
Vertically perforated clay bricks, acc. to EN 771-1:2011, HLz	C	$\geq 1,0$	12	Cross section reduced more than 15% and less than 50% by perforation vertically to the resting area. Exterior web thickness ≥ 14 mm	R	1,2
Lightweight concrete hollow blocks, acc. to EN 771-3:2011, Hbl	C	$\geq 0,9$	2	Cross section reduced more than 15% and less than 50% by perforation vertically to the resting area. Exterior web thickness ≥ 38 mm	R	0,4
Lightweight aggregate concrete, acc. to EN 1520:2011, LAC2	D	$\geq 0,8$	2	-	R	0,2
Autoclaved aerated concrete blocks, acc. to EN 771-4:2011, AAC	E	$\geq 0,5$	4	-	R	0,4

¹⁾ See Annex B1

²⁾ R = Rotary drilling | H = Hammer drilling

fischer screwed-in anchor TERMOZ 8 SV

Performance
Characteristic resistance

Annex C1

Table C2.1: Point thermal transmittance acc. to EOTA Technical Report TR 025 : 2016 – 05

Anchor type	Thickness of insulation material h_D [mm]	Point thermal transmittance χ [W/K]
TERMOZ 8 SV	80 - 220	0,002

Table C2.2: Plate stiffness acc. to EOTA Technical Report TR 026 : 2016 – 05

Anchor type	Diameter of the anchor plate [mm]	Load resistance of the anchor plate [kN]	Plate stiffness [kN/mm]
TERMOZ 8 SV	60	2,13	1,1

Table C2.3: Displacements

Base material	Tension load F [kN]	Displacements δ [mm]
Concrete C12/15 – C50/60, acc. to EN 206-1:2000	0,5	< 0,5
Lightweight concrete hollow blocks, acc. to EN 771-3:2011, Hbl	0,13	< 0,3
Lightweight concrete solid blocks, acc. to EN 771-3:2011, Vbl	0,1	< 0,2
Lightweight aggregate concrete, acc. to EN 1520:2011, LAC2	0,07	< 0,2
Autoclaved aerated concrete blocks, acc. to EN 771-4:2011, AAC	0,13	< 0,2
Solid clay bricks, acc. to EN 771-1:2011, Mz	0,5	< 0,5
Calcium silicate solid bricks, acc. to EN 771-2:2011, KS	0,5	< 0,5
Vertically perforated clay bricks, acc. to EN 771-1:2011, HLz	0,4	< 0,4
Hollow calcium silicate brick, acc. to EN 771-2:2011, KSL	0,5	< 0,5

fischer screwed-in anchor TERMOZ 8 SV

Performance
Point thermal transmittance, plate stiffness and displacements

Annex C2