



## DECLARATION OF PERFORMANCE



DoP: 0126

for fischer injection system FIS V for use in masonry: (Metal injection anchors for use in masonry) – EN

1. Unique identification code of the product-type: **DoP: 0126**
2. Intended use/es: **Anchorage in masonry for which requirements for mechanical resistance and stability and safety in use shall be fulfilled. They are for fixing and/or supporting structural elements (which contribute to the stability of the works) or heavy units, see appendix, especially Annexes B 1 to B 15**
3. Manufacturer: **fischerwerke GmbH & Co. KG, Otto-Hahn-Straße 15, 79211 Denzlingen, Germany**
4. Authorised representative: --
5. System/s of AVCP: **1**
6. European Assessment Document: **ETAG 029; 2013-04**  
European Technical Assessment: **ETA-10/0383; 2017-10-06**  
Technical Assessment Body: **DIBt**  
Notified body/ies: **1343 – MPA Darmstadt**

7. Declared performance/s:

**Mechanical resistance and stability (BWR 1), Safety and accessibility (BWR 4)**

- **Characteristic resistance for tension and shear loads: See appendix, especially Annexes C 1 to C 109**
- **Displacements under shear and tension loads: See appendix, especially Annex C 110**
- **Reduction Factor for job site tests ( $\beta$ -Factor): See appendix, especially Annex C 110**
- **Edge distances and spacing: See appendix, especially Annexes C 3 to C 109**

**Safety in case of fire (BWR 2)**

- **Reaction to fire: Anchorages satisfy requirements for Class A 1**
- **Resistance to fire: NPD**

8. Appropriate Technical Documentation and/or Specific Technical Documentation: ---

The performance of the product identified above is in conformity with the set of declared performance/s. This declaration of performance is issued, in accordance with Regulation (EU) No 305/2011, under the sole responsibility of the manufacturer identified above.

Signed for and on behalf of the manufacturer by:

Andreas Bucher, Dipl.-Ing.

Wolfgang Hengesbach, Dipl.-Ing., Dipl.-Wirtsch.-Ing.

Tumlingen, 2017-10-16

- This DoP has been prepared in different languages. In case there is a dispute on the interpretation the english version shall always prevail.
- The Appendix includes voluntary and complementary information in English language exceeding the (language-neutrally specified) legal requirements.

**Specific part****1 Technical description of the product**

The fischer injection system FIS V for masonry is a bonded anchor (injection type) consisting of a mortar cartridge with injection mortar fischer FIS V, FIS VS and FIS VW, a perforated sieve sleeve and an anchor rod with hexagon nut and washer or an internal threaded rod in the range of M6 to M16. The steel elements are made of zinc coated steel, stainless steel or high corrosion resistant steel.

The anchor rod is placed into a drilled hole filled with injection mortar and is anchored via the bond between steel element, injection mortar and masonry and mechanical interlock.

The product description is given in Annex A.

**2 Specification of the intended use in accordance with the applicable European Assessment Document**

The performances given in Section 3 are only valid if the anchor is used in compliance with the specifications and conditions given in Annex B.

The verifications and assessment methods on which this European Technical Assessment is based lead to the assumption of a working life of the anchor of at least 50 years. The indications given on the working life cannot be interpreted as a guarantee given by the producer, but are to be regarded only as a means for choosing the right products in relation to the expected economically reasonable working life of the works.

**3 Performance of the product and references to the methods used for its assessment****3.1 Mechanical resistance and stability (BWR 1)**

Essential characteristic	Performance
Characteristic resistance for tension and shear loads	See Annex C 1 – C 109
Displacements under shear and tension loads	See Annex C 110
Reduction Factor for job site tests ( $\beta$ -Factor)	See Annex C 110
Edge distances and spacing	See Annex C 3 – C 109

**3.2 Safety in case of fire (BWR 2)**

Essential characteristic	Performance
Reaction to fire	Anchorage satisfy requirements for Class A1
Resistance to fire	No performance assessed

**3.3 Hygiene, health and the environment (BWR 3)**

Regarding dangerous substances there may be requirements (e.g. transposed European legislation and national laws, regulations and administrative provisions) applicable to the products falling within the scope of this European Technical Assessment. In order to meet the provisions of Regulation (EU) No 305/2011, these requirements need also to be complied with, when and where they apply.

**3.4 Safety and accessibility in use (BWR 4)**

The essential characteristics regarding Safety in use are included under the Basic Works Requirement Mechanical resistance and stability.

**4 Assessment and verification of constancy of performance (AVCP) system applied, with reference to its legal base**

In accordance with guideline for European technical approval ETAG 029, April 2013 used as European Assessment Document (EAD) according to Article 66 Paragraph 3 of Regulation (EU) No 305/2011 the applicable European legal act is: [97/177/EC].

The system to be applied is: 1

**Installation conditions part 1**

**Anchor rods with perforated sleeve FIS H K; Installation in perforated and solid brick masonry**

**Pre-positioned anchorage:**

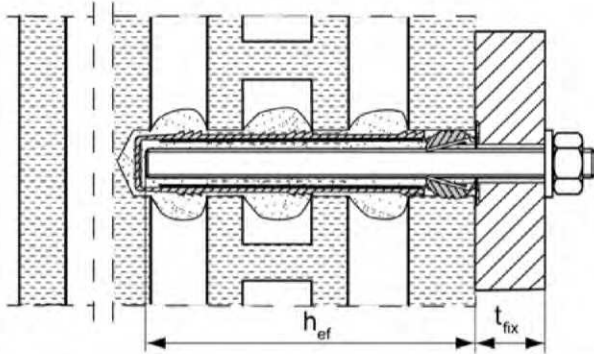

**Installation with render bridge**

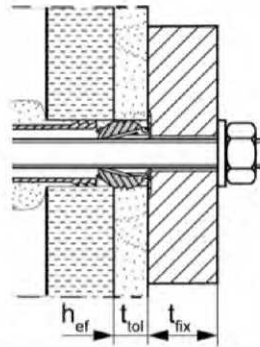

**Size of the perforated sleeve:** FIS H 12x50 K    FIS H 16x85 K    FIS H 20x85 K    FIS H 20x200 K  
 FIS H 12x85 K    FIS H 16x130 K    FIS H 20x130 K

**Push through anchorage:**

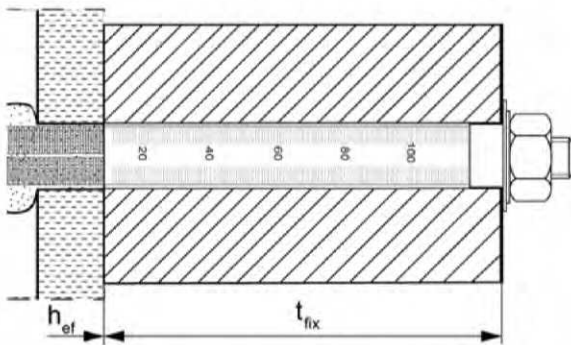

**Installation with render bridge**

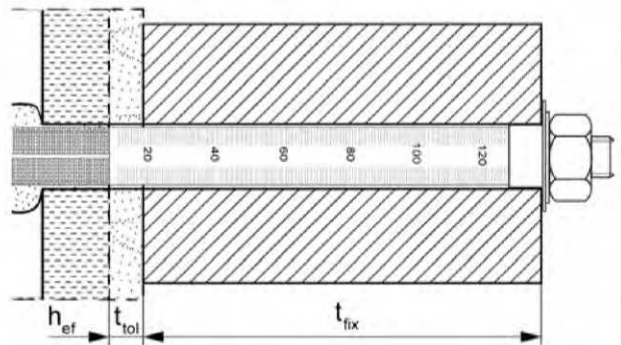

**Size of the perforated sleeve:** FIS H 18x130/200 K    FIS H 22x130/200 K

**Internal threaded anchor FIS E with perforated sleeve FIS H K; Installation in perforated and solid brick masonry**

**Pre-positioned anchorage:**

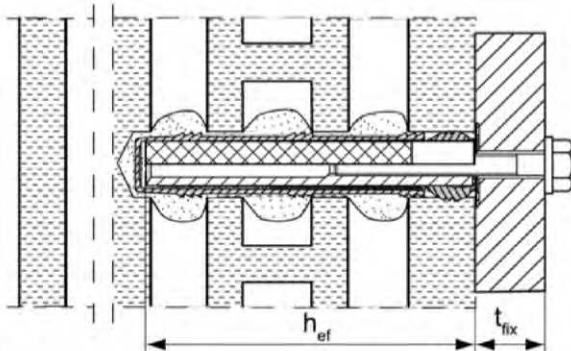

**Installation with render bridge**

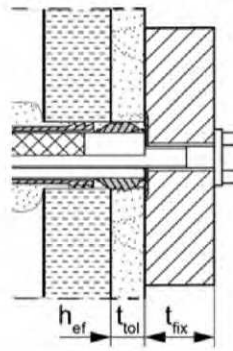

Pictures not to scale

$h_{ef}$  = effective anchorage depth

$t_{tol}$  = thickness of unbearing layer (e.g. plaster)

$t_{fix}$  = thickness of fixture

fischer injektion system FIS V masonry

**Product description**

Installation conditions part 1,  
 Anchor rods and internal threaded anchor with perforated sleeve

**Annex A 1**

**Installation conditions part 2**

**Anchor rods without perforated sleeve FIS H K;  
installation in solid brick masonry and autoclaved aerated concrete**

**Pre-positioned anchorage:**

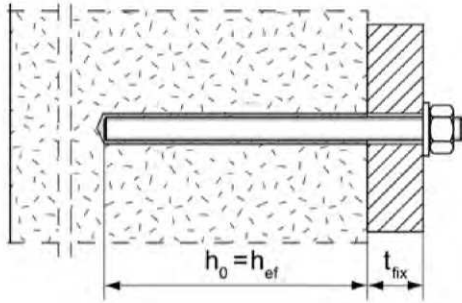

**Push through anchorage:** Annular gap filled with mortar

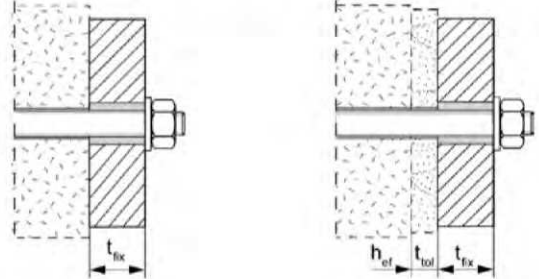

Installation with render bridge

**Internal threaded anchors FIS E without perforated sleeve FIS H K;  
installation in solid brick masonry and autoclaved aerated concrete**

**Pre-positioned anchorage:**

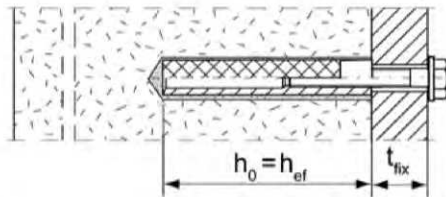

Installation with render bridge

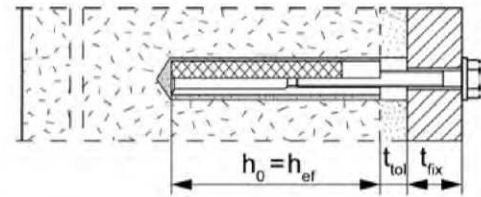

**Anchor rods and internal threaded anchors FIS E without perforated sleeve FIS H K; installation in autoclaved aerated concrete with conical drill hole (installation with special conic drill bit PBB)**

**Pre-positioned anchorage:**

anchor rods M8, M10, M12

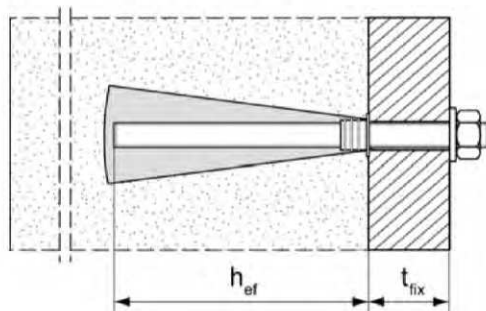

**Pre-positioned anchorage:**

Internal threaded anchor FIS E 11x85 M6 / M8

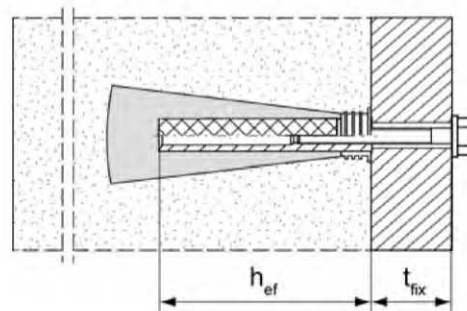

Pictures not to scale

$h_0$  = depth of drill hole

$t_{tol}$  = thickness of unbearing layer (e.g. plaster)

$h_{ef}$  = effective anchorage depth

$t_{fix}$  = thickness of fixture

fischer injektion system FIS V masonry

**Product description**

Installation conditions part 2,  
Anchor rods and internal threaded anchor without perforated sleeve

**Annex A 2**

**Overview system components part 1**

**Mortar cartridge (shuttle cartridge) with sealing cap**

①

Size: 360 ml, 585 ml, 950 ml

**Imprint:** fischer FIS V or FIS VS or FIS VW, processing notes, shelf-life, hazard code, piston travel scale (optional), curing time and processing time (depending on temperature), size, volume

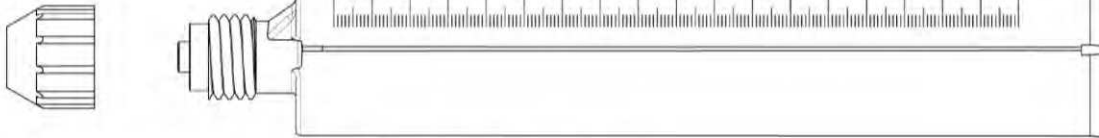

**Mortar cartridge (coaxial cartridge) with sealing cap**

①

Size: 100 ml, 150 ml, 300 ml, 380 ml, 400 ml, 410 ml

**Imprint:** fischer FIS V or FIS VS or FIS VW, processing notes, shelf-life, hazard code, piston travel scale (optional), curing time and processing time (depending on temperature), size, volume

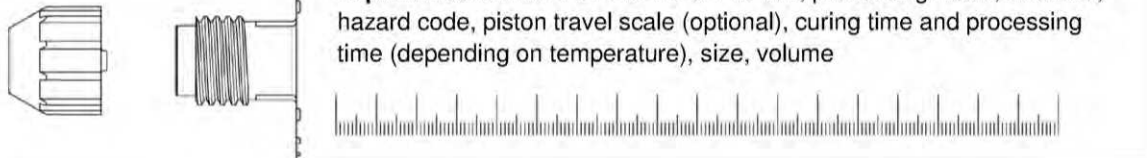

**Static mixer ME / MR with injection adapter and center sleeve for aerated concrete**

center sleeve

Injection adapter

Static mixer



**Cleaning brush BS / BSB**



**Blow-out pump ABG or ABP**







Pictures not to scale

fischer injektion system FIS V masonry

**System description**

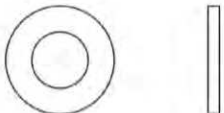
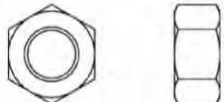

Overview system components part 1: cartridge / static mixer / cleaning brush

**Annex A 3**

Overview system components part 2	
<p>fischer anchor rod</p> <p>②  Size: M6, M8, M10, M12, M16</p>	
<p>Internal threaded anchor FIS E</p> <p>⑤  Size: 11x85 M6 / M8 15x85 M10 / M12</p>	
<p>Perforated sleeve FIS H K</p> <p>⑦  Size: FIS H 12x50 K FIS H 12x85 K FIS H 16x85 K FIS H 20x85 K</p> <p>⑦  Size: FIS H 16x130 K FIS H 20x130 K FIS H 20x200 K</p>	
<p>Perforated sleeve FIS H K (push through anchorage)</p> <p>⑦  Size: FIS H 18x130/200 K FIS H 22x130/200 K</p>	
<p>Washer</p> <p>③ </p>	
<p>Hexagon nut</p> <p>④ </p>	
Pictures not to scale	
<p>fischer injektion system FIS V masonry</p>	<b>Annex A 4</b>
<p><b>System description</b> Overview system components part 2: steel parts / perforated sleeve</p>	

<b>Table A5.1: Materials</b>				
<b>Part</b>	<b>Designation</b>	<b>Material</b>		
1	Mortar cartridge	Mortar, hardener; filler		
		Steel, zinc plated	Stainless steel A4	High corrosion-resistant steel C
2	Anchor rod	Property class 4.6; 4.8; 5.8 oder 8.8; EN ISO 898-1: 2013 zinc plated $\geq 5\mu\text{m}$ , EN ISO 4042:1999 A2K or hot-dip galvanised EN ISO 10684:2004 $f_{uk} \leq 1000 \text{ N/mm}^2$ $A_5 > 8\%$ fracture elongation	Property class 50, 70 or 80 EN ISO 3506-1:2009 1.4401; 1.4404; 1.4578; 1.4571; 1.4439; 1.4362; 1.4062 EN 10088-1:2014 $f_{uk} \leq 1000 \text{ N/mm}^2$ $A_5 > 8\%$ fracture elongation	Property class 50 or 80 EN ISO 3506-1:2009 or property class 70 with $f_{yk} = 560 \text{ N/mm}^2$ 1.4565; 1.4529 EN 10088-1:2014 $f_{uk} \leq 1000 \text{ N/mm}^2$ $A_5 > 8\%$ fracture elongation
3	Washer ISO 7089:2000	zinc plated $\geq 5\mu\text{m}$ , EN ISO 4042:1999 A2K or hot-dip galvanised EN ISO 10684:2004	1.4401; 1.4404; 1.4578; 1.4571; 1.4439; 1.4362 EN 10088-1:2014	1.4565; 1.4529 EN 10088-1:2014
4	Hexagon nut	Property class 5 or 8; EN ISO 898-2:2012 zinc plated $\geq 5\mu\text{m}$ , ISO 4042:1999 A2K or hot-dip galvanised ISO 10684:2004	Property class 50, 70 or 80 EN ISO 3506-1:2009 1.4401; 1.4404; 1.4578; 1.4571; 1.4439; 1.4362 EN 10088-1:2014	Property class 50, 70 or 80 EN ISO 3506-1:2009 1.4565; 1.4529 EN 10088-1:2014
5	Internal threaded anchor FIS E	Property class 5.8; EN 10277-1:2008-06 zinc plated $\geq 5\mu\text{m}$ , ISO 4042:1999 A2K	Property class 70 EN ISO 3506-1:2009 1.4401; 1.4404; 1.4578; 1.4571; 1.4439; 1.4362 EN 10088-1:2014	Property class 70 EN ISO 3506-1:2009 1.4565; 1.4529 EN 10088-1:2014
6	Commercial standard screw or threaded / anchor rod for internal threaded anchor FIS E	Property class 5.8 or 8.8; EN ISO 898-1:2013 zinc plated $\geq 5\mu\text{m}$ , ISO 4042:1999 A2K	Property class 70 EN ISO 3506-1:2009 1.4401; 1.4404; 1.4578; 1.4571; 1.4439; 1.4362 EN 10088-1:2014	Property class 70 EN ISO 3506-1:2009 1.4565; 1.4529 EN 10088-1:2014
7	Perforated sleeve	PP / PE		
fischer injektion system FIS V masonry				<b>Annex A 5</b>
<b>Product description</b> Materials				



<b>Specifications of intended use (part 1)</b>		
<b>Table B1.1: Overview use and performance categories</b>		
Anchorage subject to	<b>fischer injection system FIS V masonry</b>	
Hole drilling with hammer drill mode 	all bricks; without C26 to C45, C73 to C76	
Hole drilling with rotary drill mode 	all bricks	
Static and quasi static load, in masonry	all bricks	
Use category    dry or wet masonry	all bricks	
Installation	Pre-positioned anchorage	Anchor rod (in solid brick masonry and autoclaved aerated concrete)  Perforated sleeve (in perforated and solid brick masonry)  Size:    FIS H 12x50 K FIS H 12x85 K FIS H 16x85 K FIS H 16x130 K FIS H 20x85 K FIS H 20x130 K FIS H 20x200 K
	Push through anchorage	Anchor rod (in solid brick masonry and autoclaved aerated concrete)  Perforated sleeve (in perforated and solid brick masonry)  Size:    FIS H 18x130/200 K FIS H 22x130/200 K
Installation conditions	category d/d category w/d category w/w	all bricks
Installation temperature	-10°C to +40°C	
In-service temperature	-40°C to +80°C	max. short term temperature +80 °C and max. long term temperature +50 °C
	-40°C to +120°C	max. short term temperature +120 °C and max. long term temperature +72 °C
fischer injektion system FIS V masonry		<b>Annex B 1</b>
<b>Intended Use</b> Specifications (part 1)		

**Specifications of intended use (part 2)****Anchorage subject to:**

- Static and quasi-static loads

**Base materials:**

- Solid brick masonry (Use category b) and autoclaved aerated concrete (Use category d), acc. to Annex B 13 / B 14
- Hollow brick masonry (use category c), according to Annex B 13 / B 14
- For minimum thickness of masonry member is  $h_{ef}+30\text{mm}$
- Mortar strength class of the masonry M2,5 at minimum according to EN 998-2:2010
- For other bricks in solid masonry, hollow or perforated masonry and autoclaved aerated concrete, the characteristic resistance of the anchor may be determined by job site tests according to ETAG 029, Annex B under consideration of the  $\beta$ -factor according to Annex C 110, Table C110.1

Note (only applies to solid bricks and autoclaved aerated concrete):

The characteristic resistance is also valid for larger brick sizes, higher compressive strength and higher raw density of the masonry unit.

**Temperature Range:**

- **I:** From - 40°C to +80°C (max. short term temperature +80°C and max. long term temperature +50°C)
- **II:** From -40°C to +120°C (max. short term temperature +120°C and max. long term temperature +72°C)

**Use conditions (Environmental conditions):**

- Dry and wet structure (regarding injection mortar)
- Structures subject to dry internal conditions exist  
(zinc coated steel, stainless steel or high corrosion resistant steel)
- Structures subject to external atmospheric exposure including industrial and marine environment or exposure to permanently damp internal condition, if no particular aggressive conditions exist exist  
(stainless steel or high corrosion resistant steel)
- Structures subject to external atmospheric exposure and to permanently damp internal condition, if other particular aggressive conditions exist (high corrosion resistant steel)

Note: Particular aggressive conditions are e.g. permanent, alternating immersion in seawater or the splash zone of seawater, chloride atmosphere of indoor swimming pools or atmosphere with extreme chemical pollution (e.g. in desulphurization plants or road tunnels where de-icing materials are used)

fischer injektion system FIS V masonry

**Intended Use**  
Specifications (part2)

**Annex B 2**

**Specifications of intended use (part 2)****Design:**

- The anchorages have to be designed in accordance with the ETAG 029, Annex C, Design method A under the responsibility of an engineer experienced in anchorages and masonry work.

Applies to all bricks, if no other values are specified:

$$N_{Rk} = N_{Rk,b} = N_{Rk,p}$$

$$V_{Rk} = V_{Rk,b} = V_{Rk,c}$$

For the Calculation of pulling out a brick under tensile load  $N_{Rk,pb}$  or pushing out a brick under shear load  $V_{Rk,pb}$  see ETAG 029, Annex C.

$N_{Rk,s}$ ,  $V_{Rk,s}$  and  $M_{Rk,s}$  see annex C1-C3

Factors for job site tests and displacements see Annex C110

- Verifiable calculation notes and drawings have to be prepared taking account the relevant masonry in the region of the anchorage, the loads to be transmitted and their transmission to the supports of the structure. The position of the anchor is indicated on the design drawings.

**Installation:**

- Category d/d: - Installation and use in dry structures
- Category w/w: - Installation and use in dry and wet structures
- Category w/d: - Installation in wet structures and use in dry structures
- Hole drilling see Annex C (drilling method)
- In case of aborted hole: The hole shall be filled with mortar
- Bridging of unbearing layer (e.g. plaster) see Annex B 6, Table B6.1
- Anchor installation carried out by appropriately qualified personnel and under the supervision of the person responsible for technical matters of the site
- Fastening screws or anchor rods (including nut and washer) must comply with the appropriate material and property class of the fischer internal threaded anchor FIS E.
- minimum curing time see Annex B 8, Table B8.2

Commercial standard threaded rods, washers and hexagon nuts may also be used if the following requirements are fulfilled:

Material dimensions and mechanical properties of the metal parts according to the specifications are given in Annex A 5, Table 5.1

Conformation of material and mechanical properties of the metal parts by inspection certificate 3.1 according to EN 10204:2004, the documents shall be stored

Marking of the anchor rod with the envisage embedment depth. This may be done by the manufacturer of the rod or by a person on job site

fischer injektion system FIS V masonry

**Intended Use**  
Specifications (part2)

**Annex B 3**

**Table B4.1:** Installation parameters for anchor rods in solid bricks and autoclaved aerated concrete without perforated sleeves

Anchor rod	Thread	M6	M8	M10	M12	M16
Nominal drill hole diameter	$d_0$ [mm]	8	10	12	14	18
Effective anchorage depth $h_{ef}^{1)}$ in AAC cylindrical drill hole	$h_0 = h_{ef, min}$ [mm]	100				
Effective anchorage depth $h_{ef}^{1)}$ in AAC conical drill hole	$h_{0, min}$ [mm]	-	80			-
	$h_{ef, min}$ [mm]		75			
	$h_{ef, max}$ [mm]		95			
Effective anchorage depth $h_{ef}^{1)}$ in solid brick (depth of drill hole $h_0 = h_{ef}$ )	$h_{ef, min}$ [mm]	50				
	$h_{ef, max}$ [mm]	$h-30, \leq 200$				
Diameter of clearance hole in the fixture	pre-position $d_f \leq$ [mm]	7	9	12	14	18
	push through $d_f \leq$ [mm]	9	11	14	16	20
Diameter of cleaning brush	$d_b \geq$ [mm]	see Table B8.1				
Maximum installation torque	$T_{inst, max}$ [Nm]	see parameters of brick				

<sup>1)</sup>  $h_{ef, min} \leq h_{ef} \leq h_{ef, max}$  is possible.

**fischer anchor rods FIS A M6, M8, M10, M12, M16**

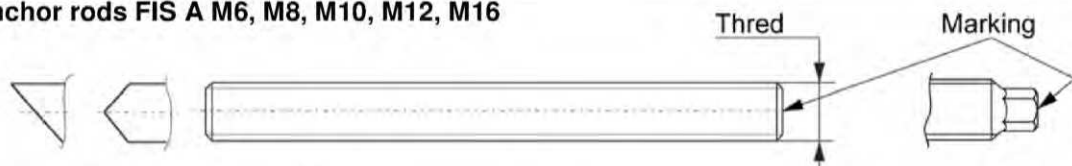

**Marking:**

Property class 8.8, stainless steel A4 property class 80 and high corrosion resistant steel C property class 80: •  
 Stainless steel A4 property class 50 and high corrosion resistant steel C property class 50: ••  
 Or colour coding according to DIN 976-1:2016-09, property class 4.6 marking according to EN ISO 898-1:2013

**Installation conditions:**

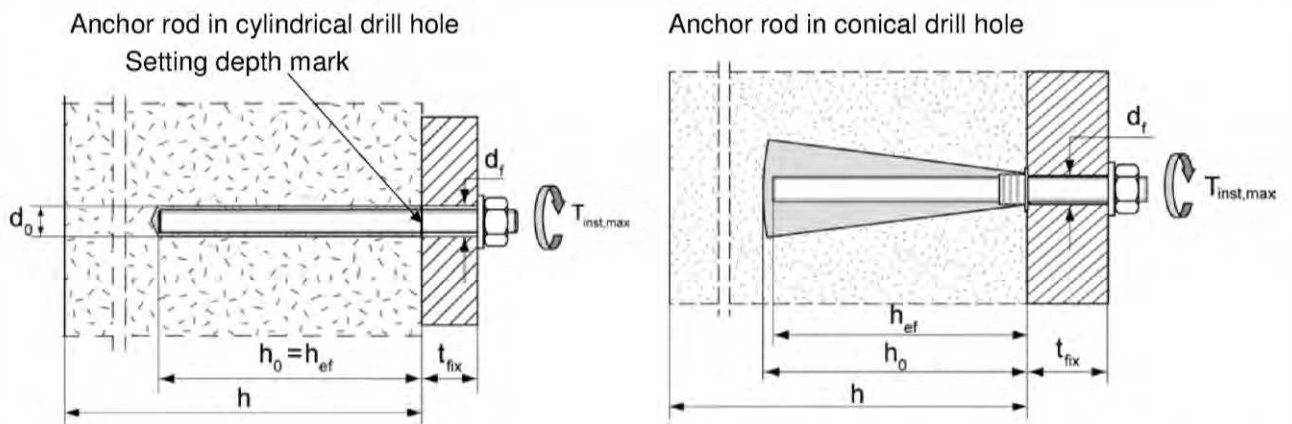

Pictures not to scale

fischer injektion system FIS V masonry

**Intended Use**

Installation parameters for anchor rods without perforated sleeve

**Annex B 4**

**Table B5.1:** Installation parameters for internal threaded anchors FIS E in solid bricks and autoclaved aerated concrete without perforated sleeves

Internal threaded anchor FIS E		11x85 M6	11x85 M8	15x85 M10	15x85 M12
Diameter of anchor	$d_H$ [mm]	11		15	
Nominal drill hole diameter	$d_0$ [mm]	14		18	
Length of anchor	$L_H$ [mm]	85			
Effective anchorage depth	$h_0 = h_{ef}$ [mm]	85			
Effective anchorage depth $h_{ef}$ in AAC (conical drill hole)	$h_0$ [mm]	100		-	
	$h_{ef}$ [mm]	85			
Diameter of cleaning brush	$d_b \geq$ [mm]	see Table B8.1			
Maximum installation torque	$T_{inst,max}$ [Nm]	see parameters of brick			
Diameter of clearance hole in the fixture	$d_f$ [mm]	7	9	12	14
Screw-in depth	$l_{E,min}$ [mm]	6	8	10	12
	$l_{E,max}$ [mm]	60			

**fischer Internal threaded anchor FIS E**

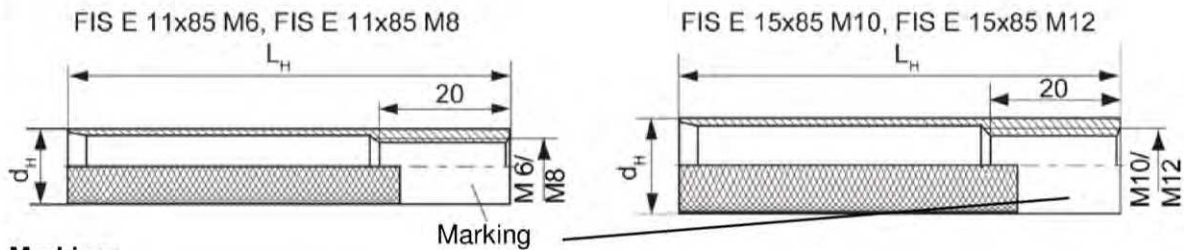

**Marking:**

Size, e.g. **M8**, Stainless steel: A4, e.g. **M8 A4**, High corrosion-resistant steel: C, e.g. **M8 C**

**Installation conditions:**

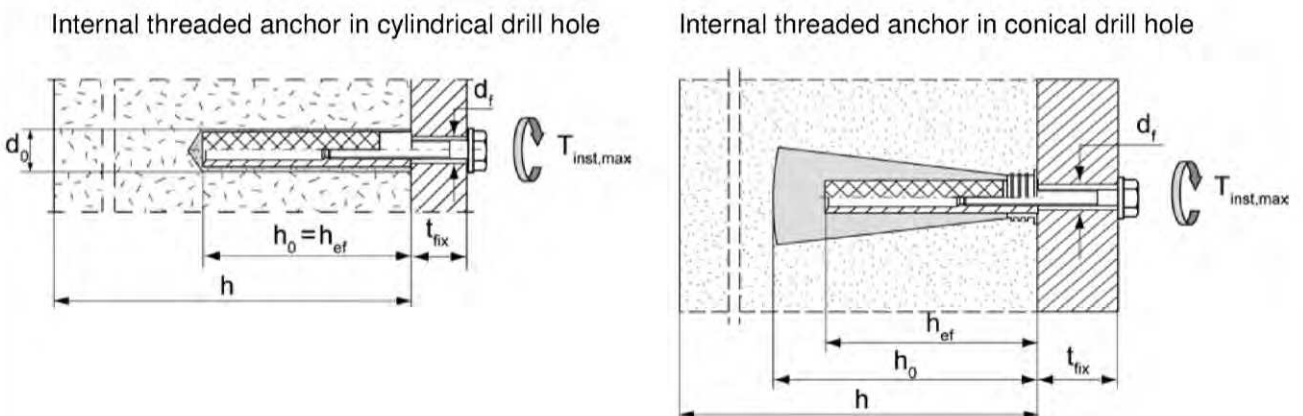

Pictures not to scale

fischer injektion system FIS V masonry

**Intended Use**

Installation parameters for internal threaded rods FIS E without perforated sleeve

**Annex B 5**

**Table B6.1:** Installation parameters for anchor rods and internal threaded anchors FIS E with perforated sleeves (pre-positioned anchorage)

perforated sleeve FIS H K		12x50	12x85 <sup>2)</sup>	16x85	16x130 <sup>2)</sup>	20x85	20x130 <sup>2)</sup>	20x200 <sup>2)</sup>
Nominal drill hole diameter $d_0 = D_{\text{sleeve, nom}}$	$d_0$ [mm]	12		16		20		
Depth of drill hole	$h_0$ [mm]	55	90	90	135	90	135	205
Effective anchorage depth	$h_{\text{ef, min}}$ [mm]	50	65	85	110	85	110	180
	$h_{\text{ef, max}}$ [mm]	50	85	85	130	85	130	200
Size of threaded rod	[-]	M6 und M8		M8 und M10		M12 und M16		
Size of internal threaded anchor FIS E		-	-	11x85	-	15x85	-	-
Diameter of cleaning brush <sup>1)</sup>	$d_b \geq$ [mm]	see Table B8.1						
Maximum installation torque	$T_{\text{inst, max}}$ [Nm]	see parameters of brick						

<sup>1)</sup> Only for solid areas in hollow bricks and solid bricks.

<sup>2)</sup> Bridging of unbearing layer (e.g. plaster) is possible. When reducing the effective anchorage depth  $h_{\text{ef, min}}$ , the values of the next shorter perforated sleeve of the same diameter must be used. The smaller value of characteristic resistance must be taken.

**Perforated sleeve**

FIS H 12x50 K; FIS H 12x85 K; FIS H 16x85 K; FIS H 16x130 K;  
FIS H 20x85 K; FIS H 20x130 K; FIS H 20x200 K

**Marking:**

Size  $D_{\text{sleeve, nom}} \times L_{\text{sleeve}}$   
(e.g.: 16x85)

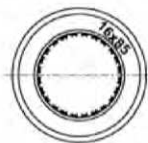

$D_{\text{sleeve, nom}}$

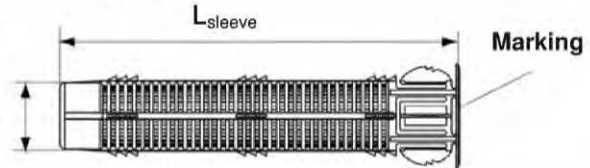

**fischer Internal threaded anchor FIS E**

FIS E 11x85 M6, FIS E 11x85 M8

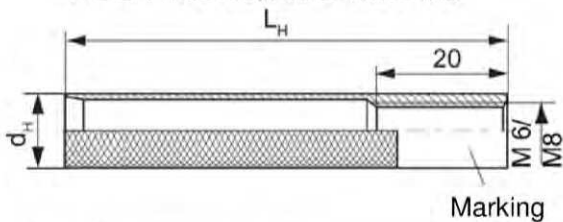

FIS E 15x85 M10, FIS E 15x85 M12

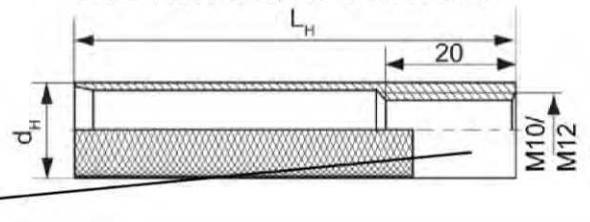

**Installation conditions:**

Anchor rod with perforated sleeve

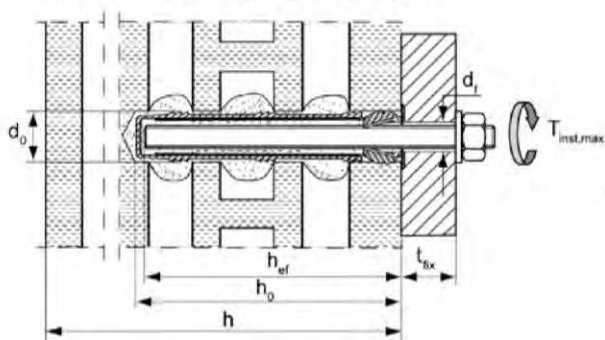

Internal threaded anchor with perforated sleeve

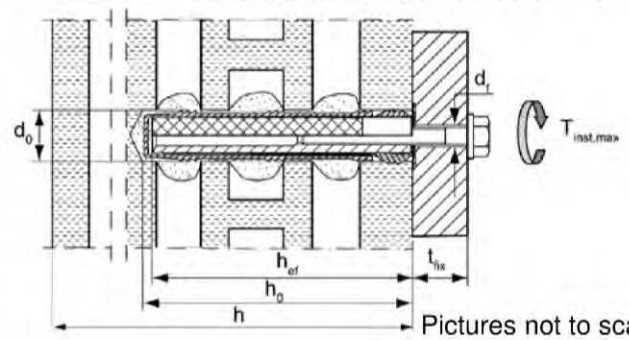

Pictures not to scale

fischer injektion system FIS V masonry

**Intended Use**

Installation parameters for anchor rods and internal threaded anchors FIS E with perforated sleeve (pre-positioned anchorage)

**Annex B 6**

**Table B7.1:** Installation parameters for anchor rods with perforated sleeves (push through anchorage)

Perforated sleeve FIS H K		18x130/200	22x130/200
Nominal sleeve diameter	$D_{\text{sleeve,nom}}$ [mm]	16	20
Nominal drill hole diameter	$d_0$ [mm]	18	22
Depth of drill hole	$h_0$ [mm]	135 + $t_{\text{fix}}$	
Effective anchorage depth	$h_{\text{ef}}$ [mm]	≥130	
Diameter of cleaning brush <sup>1)</sup>	$d_b \geq$ [mm]	Siehe Tabelle B8.1	
Size of threaded rod	[-]	M10	M12
Maximum installation torque	$T_{\text{inst,max}}$ [Nm]	see parameters of brick	
Thickness of fixture	$t_{\text{fix,max}}$ [mm]	200	

<sup>1)</sup> Only for solid areas in hollow bricks and solid bricks.

**Perforated sleeve**

FIS H 18x130/200 K; FIS H 22x130/200 K

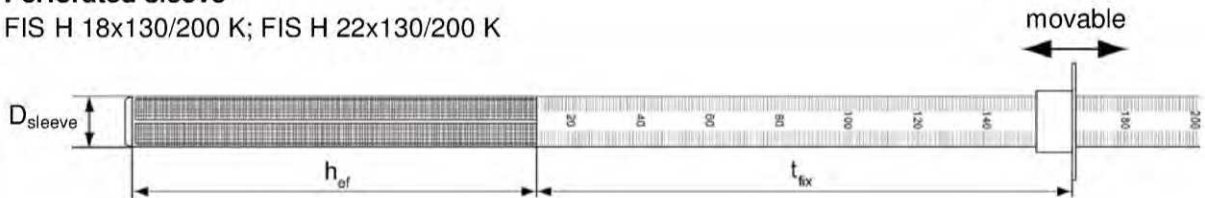

**Installation conditions:**

Anchor rod with perforated sleeve

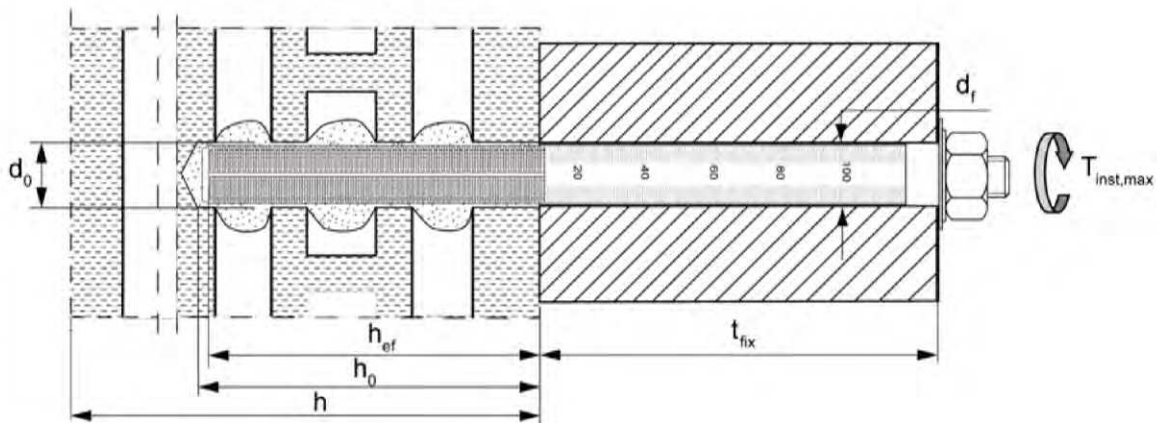

Pictures not to scale

fischer injektion system FIS V masonry

**Intended Use**

Installation parameters for anchor rods with perforated sleeves (push through anchorage)

**Annex B 7**

**Tabelle B8.1:** Parameters of the cleaning brush BS (steel brush)

The size of the cleaning brush refers to the drill hole diameter

Drill hole diameter	$d_0$ [mm]	8	10	12	14	16	18	20	22
Brush diameter	$d_b$ [mm]	9	11	14	16	20	20	25	25

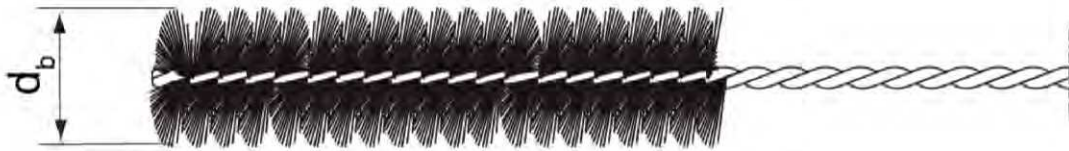

Only for solid bricks and autoclaved aerated concrete

**Table B8.2:** Maximum processing times and minimum curing times  
(During the curing time of the mortar the masonry temperature may not fall below the listed minimum temperature)

Temperature at anchoring base [°C]	Minimum curing time <sup>1)</sup> $t_{cure}$		
	FIS VW High Speed <sup>3)</sup>	FIS V <sup>2)</sup>	FIS VS Low Speed <sup>2)</sup>
-10 to -5	12 h	-	-
>-5 to ±0	3 h	24 h	-
±0 to +5	3 h	3 h	6 h
>+5 to +10	50 min	90 min	3 h
>+10 to +20	30 min	60 min	2 h
>+20 to +30	-	45 min	60 min
>+30 to +40	-	35 min	30 min

System-temperature (mortar) [°C]	Maximum processing time $t_{work}$		
	FIS VW High Speed <sup>3)</sup>	FIS V <sup>2)</sup>	FIS VS Low Speed <sup>2)</sup>
-	-	-	-
±0	5 min	-	-
+5	5 min	13 min	20 min
+10	3 min	9 min	20 min
+20	1 min	5 min	10 min
+30	-	4 min	6 min
+40	-	2 min	4 min

<sup>1)</sup> For wet bricks the curing time must be doubled

<sup>2)</sup> Minimum cartridge temperature +5°C

<sup>3)</sup> Minimum cartridge temperature ±0°C

Pictures not to scale

fischer injektion system FIS V masonry





**Intended use**  
Cleaning brush (steel brush)  
Maximum processing times and minimum curing times

**Annex B 8**

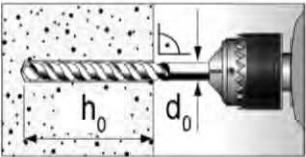
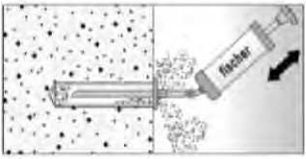
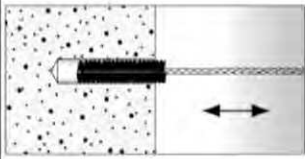
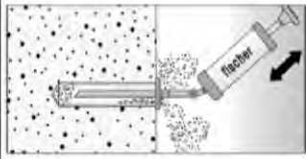
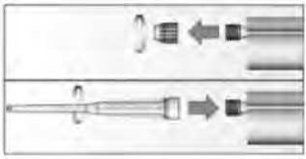

**Installation instruction part 1**

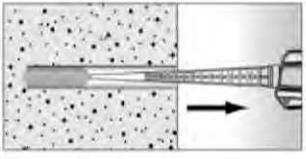
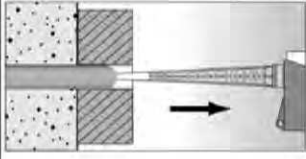
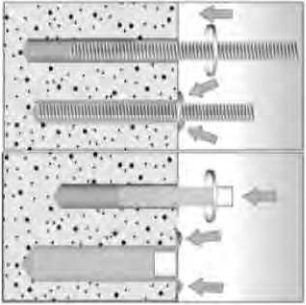
Installation in solid brick and autoclaved aerated concrete (without perforated sleeve)

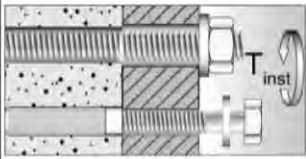



1		<p>Drill the hole (drilling method see Annex C of the respective brick) depth of drill hole <math>h_0</math> and drill hole diameter <math>d_0</math> see <b>Table B4.1; B5.1</b></p>		
2				<p>Blow out the drill hole twice. Brush twice and blow out twice again.</p>
3		<p>Remove the sealing cap. Screw on the static mixer. (the spiral in the static mixer must be clearly visible)</p>		
4		<p>Place the cartridge into a suitable dispenser</p>		<p>Press out approximately 10 cm of mortar until the resin is permanently grey in colour. Mortar which is not grey in colour will not cure and must be disposed of.</p>
5		<p>Fill approximately 2/3 of the drill hole with mortar beginning from the bottom of the hole<sup>1)</sup>. Avoid bubbles!</p>		<p>For push through anchorage fill the annular clearance with mortar.</p>
6		<p>Only use clean and oil-free anchor elements. Mark the anchor rod for setting depth. Insert the anchor rod or internal threaded anchor FIS E by hand using light turning motions. When reaching the setting depth marking, excess mortar must emerge from the mouth of the drill hole.</p>		
7		<p>Do not touch. Minimum curing time see <b>Table B8.2</b></p>		<p>Mounting the fixture. <math>T_{inst,max}</math> see parameter of brick.</p>

<sup>1)</sup> Exact volume of mortar see manufacturer's specification.

fischer injektion system FIS V masonry

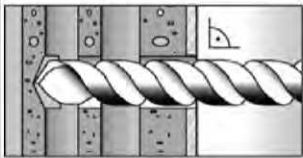
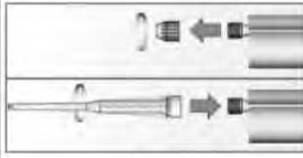

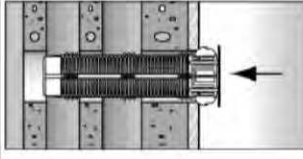
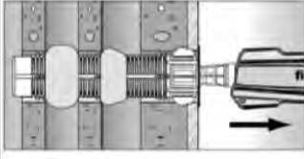
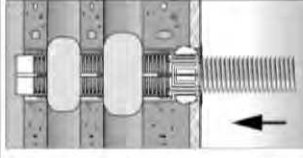
**Intended use**  
Installation instruction (without perforated sleeve) part 1

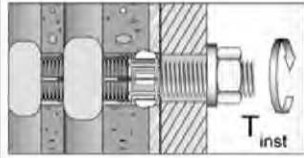
**Annex B 9**

<b>Installation instruction part 2</b>				
<b>Installation in perforated or solid brick with perforated sleeve (pre-positioned anchorage)</b>				
<b>1</b>		Drill the hole (drilling method see Annex C of the respective brick). depth of drill hole $h_0$ and drill hole diameter $d_0$ see <b>Table B6.1</b>	When install perforated sleeves in solid bricks or solid areas of hollow bricks, also clean the hole by blowing out and brushing.	
<b>2</b>		Remove the sealing cap. Screw on the static mixer. (the spiral in the static mixer must be clearly visible)		
<b>3</b>		Place the cartridge into a suitable dispenser.		Press out approximately 10 cm of mortar until the resin is permanently grey in colour. Mortar which is not grey in colour will not cure and must be disposed of.
<b>4</b>		Insert the perforated sleeve flush with the surface of the masonry or plaster.		Fill the perforated sleeve completely with mortar beginning from the bottom of the hole <sup>1)</sup> .
<b>5</b>		Only use clean and oil-free anchor elements. Mark the anchor rod for setting depth. Insert the anchor rod or the internal threaded anchor FIS E by hand using light turning motions until reaching the setting depth marking (anchor rod) or flush with the surface (internal threaded anchor).		
<b>6</b>		Do not touch. Minimum curing time see <b>Table B8.2</b>		Mounting the fixture. $T_{inst,max}$ see parameter of brick.
<sup>1)</sup> Exact volume of mortar see manufacturer's specification.				
fischer injektion system FIS V masonry			<b>Annex B 10</b>	
<b>Intended use</b> Installation instruction (with perforated sleeve) part 2				

**Installation instruction part 3**

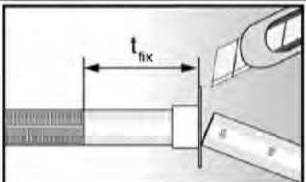
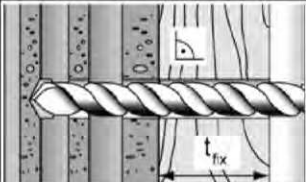
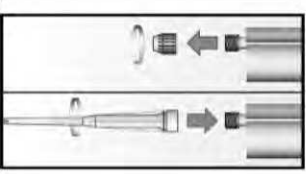
Installation in perforated or solid brick with perforated sleeve (push through anchorage)

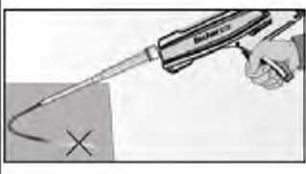
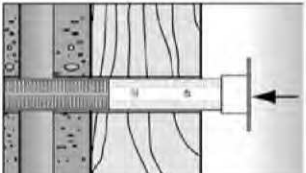
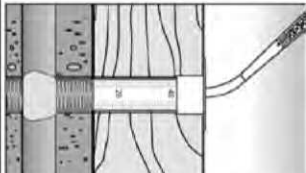
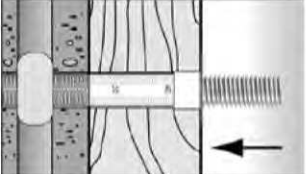
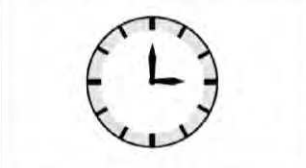
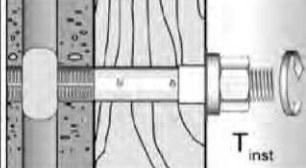
1		<p>Push the movable stop up to the correct thickness of fixture and cut the overlap.</p>		<p>Drill the hole through the fixture. Depth of drill hole (<math>h_0 + t_{fix}</math>) and drill hole diameter see <b>Table B7.1</b></p>
2		<p>Remove the sealing cap. Screw on the static mixer. (the spiral in the static mixer must be clearly visible)</p>		
3		<p>Place the cartridge into a suitable dispenser.</p>		<p>Press out approximately 10 cm of mortar until the resin is permanently grey in colour. Mortar which is not grey in colour will not cure and must be disposed of.</p>
4		<p>Insert the perforated sleeve flush with the surface of the fixture into the drill hole.</p>		<p>Fill the sleeve with mortar beginning from the bottom of the hole.<sup>1)</sup> For deep drill holes use an extension tube.</p>
5		<p>Only use clean and oil-free anchor elements. Mark the anchor rod for setting depth. Insert the anchor rod or the internal threaded anchor FIS E by hand using light turning motions until reaching the setting depth marking (anchor rod) or flush with the surface (internal threaded anchor).</p>		
6		<p>Do not touch. Minimum curing time see <b>Table B8.2</b></p>		<p>Mounting the fixture. <math>T_{inst,max}</math> see parameter of brick.</p>

<sup>1)</sup> Exact volume of mortar see manufacturer's specification.







fischer injektion system FIS V masonry

**Intended use**  
Installation instruction (with perforated sleeve) part 3

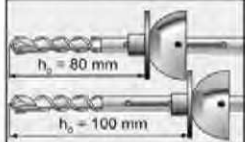
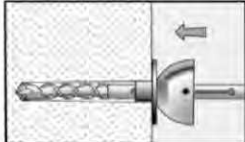
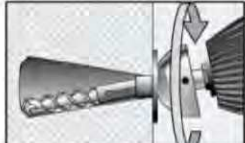
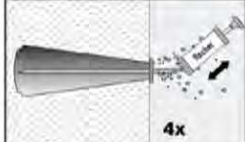
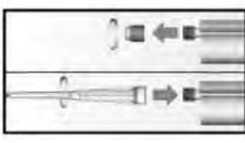
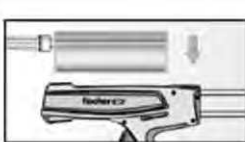
**Annex B 11**

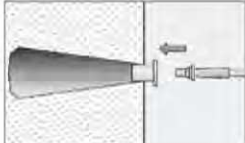
**Installation instruction part 4**

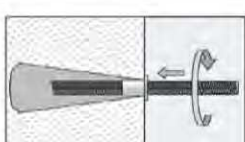
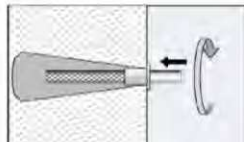
Installation in autoclaved aerated concrete with special conic drill bit PBB  
(pre-positioned anchorage)

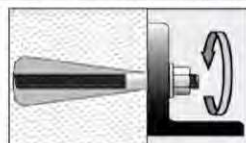
1		<p>Position the movable drill bit arrester on the used drill hole depth. For this, unlock the clamp screw and slide the arrester. Now fix the clamp screw.</p>	
2		<p>Drill the cylindrical hole with rotating drill until the arrester contact the material surface. (drilling method see Annex C of the respective brick)</p>	
3		<p>Deviate the working power drill circulate to generate an conic undercut in the material.</p>	
4		<p>Blow out the drill hole four times.</p>	
5		<p>Remove the sealing cap. Screw on the static mixer. (the spiral in the static mixer must be clearly visible)</p>	
6		<p>Place the cartridge into a suitable dispenser.</p>	 <p>Press out approximately 10 cm of mortar until the resin is permanently grey in colour. Mortar which is not grey in colour will not cure and must be disposed of.</p>
7		<p>Put the center sleeve into the drill hole and adapt the injection adapter onto the static mixer.</p>	 <p>Fill the drill hole with injection mortar.</p>
8			<p>Only use clean and oil-free anchor elements. Mark the anchor rod for setting depth. Insert the anchor rod or internal threaded anchor FIS E by hand using light turning motions. When reaching the setting depth marking, excess mortar must emerge from the mouth of the drill hole.</p>
9		<p>Do not touch. Minimum curing time see <b>Table B8.2</b></p>	 <p>Mounting the fixture. <math>T_{inst,max}</math> see parameter of brick.</p>

fischer injektion system FIS V masonry

**Intended use**

Installation instruction for autoclaved aerated concrete with special conic drill bit PBB  
(pre-positioned anchorage) part 4

**Annex B 12**

<b>Table B13.1: Overview of controlled bricks (part 1)</b>					
<b>Kind of masonry</b>	<b>Brick format [mm]</b>	<b>Compressive strength <math>f_b</math> N/mm<sup>2</sup></b>	<b>Producing country</b>	<b>Density <math>\rho</math> [kg/dm<sup>3</sup>]</b>	<b>Annex</b>
<b>Solid brick Mz</b>					
<b>Solid brick Mz</b>	<b>NF</b> ≥240x115x71	12 - 20	Germany	≥1,8	C4 - C7
	<b>2DF</b> ≥240x115x113	10 - 16	Germany	≥1,8	C8/C9
	≥ 245x118x54	10 - 20	Italy	≥1,8	C10/C11
	≥ 230x108x55	10 - 20	Denmark	≥1,8	C12/C13
<b>Solid sand- lime brick KS / perforated Sand- lime brick KSL</b>					
<b>Solid sand- lime brick KS</b>	<b>NF</b> ≥240x115x71	12 - 28	Germany	≥2,0	C14/C15
<b>Solid sand- lime brick KS</b>	<b>8DF</b> ≥ 250x240x240	10 - 28	Germany	≥2,0	C16/C17
<b>Solid sand- lime brick KS</b>	≥ 997x214x538	10 - 36	Netherlands	≥1,8	C18/C19
<b>Perforated Sand- lime brick KSL</b>	<b>3DF</b> 240x175x113	8 - 20	Germany	≥1,4	C20 - C23
<b>Vertical perforated brick HLz</b>					
<b>Vertical perforated brick HLz</b>	375x240x237	4 - 12	Germany	≥1,0	C24/C25
	500x175x237	4 - 12	Germany	≥1,0	C24/C25
	<b>2DF</b> 240x115x113	6 - 28	Germany	≥1,4	C26/C27
	248x365x248	4 - 8	Germany	≥0,6	C28 - C31
	248x365x249	8 - 12	Germany	≥0,7	C32 - C35
	248x365x249	4 - 6	Germany	≥0,5	C36 - C39
	248x425x248	4 - 8	Germany	≥0,8	C40 - C43
	248x425x248	4 - 8	Germany	≥0,6	C44 - C47
	500x200x315	4 - 8	France	≥0,6	C48 - C51
	500x200x300	4 - 10	France	≥0,7	C52 - C55
	500x200x315	2 - 8	France	≥0,7	C56 - C59
	560x200x275	4 - 8	France	≥0,7	C60/C61
	255x120x118	2 - 12	Italy	≥1,0	C62 - C64
	275x130x94	6 - 20	Spain	≥0,8	C65/C66
	220x190x290	6 - 10	Portugal	≥0,7	C67 - C70
	253x300x240	2 - 6	Austria	≥0,8	C71 - C74
	250x440x250	6 - 10	Austria	≥0,7	C75 - C78
230x108x55	2 - 8	Denmark	≥1,4	C79/C80	
<b>Horizontal perforated brick LLz</b>					
<b>Horizontal perforated brick LLz</b>	248x78x250	2 - 6	Italy	≥0,7	C81/C82
	128x88x275	2	Spain	≥0,8	C83/C84
<b>Light-weight concrete hollow block Hbl</b>					
<b>Light-weight concrete hollow block Hbl</b>	362x240x240	2 - 4	Germany	≥1,0	C85 - C88
	500x200x200	2 - 6	France	≥1,0	C89/C90
	440x215x215	4 - 10	Ireland	≥1,2	C91 - C94
fischer injektion system FIS V masonry				<b>Annex B 13</b>	
<b>Intended use</b> Overview of controlled bricks (part 1)					

**Table B14.1:** Overview of controlled bricks (part 2)

Kind of masonry	Brick format [mm]	Compressive strength $f_b$ N/mm <sup>2</sup>	Producing country	Density $\rho$ [kg/dm <sup>3</sup> ]	Annex
<b>Light-weight concrete solid block Vbl</b>					
<b>Light-weight concrete solid block Vbl</b>	≥ 372x300x254	2	Germany	≥0,6	C95/C96
	≥ 250x240x239	4 - 8	Germany	≥1,6	C97 - C100
	≥ 440x100x215	4 - 10	Ireland	≥2,0	C101/C102
	≥ 440x95x215	6 - 12	England	≥2,0	C103/C104
<b>Autoclaved aerated concrete (AAC)</b>					
<b>PP2 / AAC</b>	-	2	Germany	0,35	C105 - C109
<b>PP4 / AAC</b>	-	4	Germany	0,5	C105 - C109
<b>PP6 / AAC</b>	-	6	Germany	0,65	C105 - C109
fischer injektion system FIS V masonry					<b>Annex B 14</b>
<b>Intended use</b> Overview of controlled bricks (part 2)					

**Spacing and edge distance**

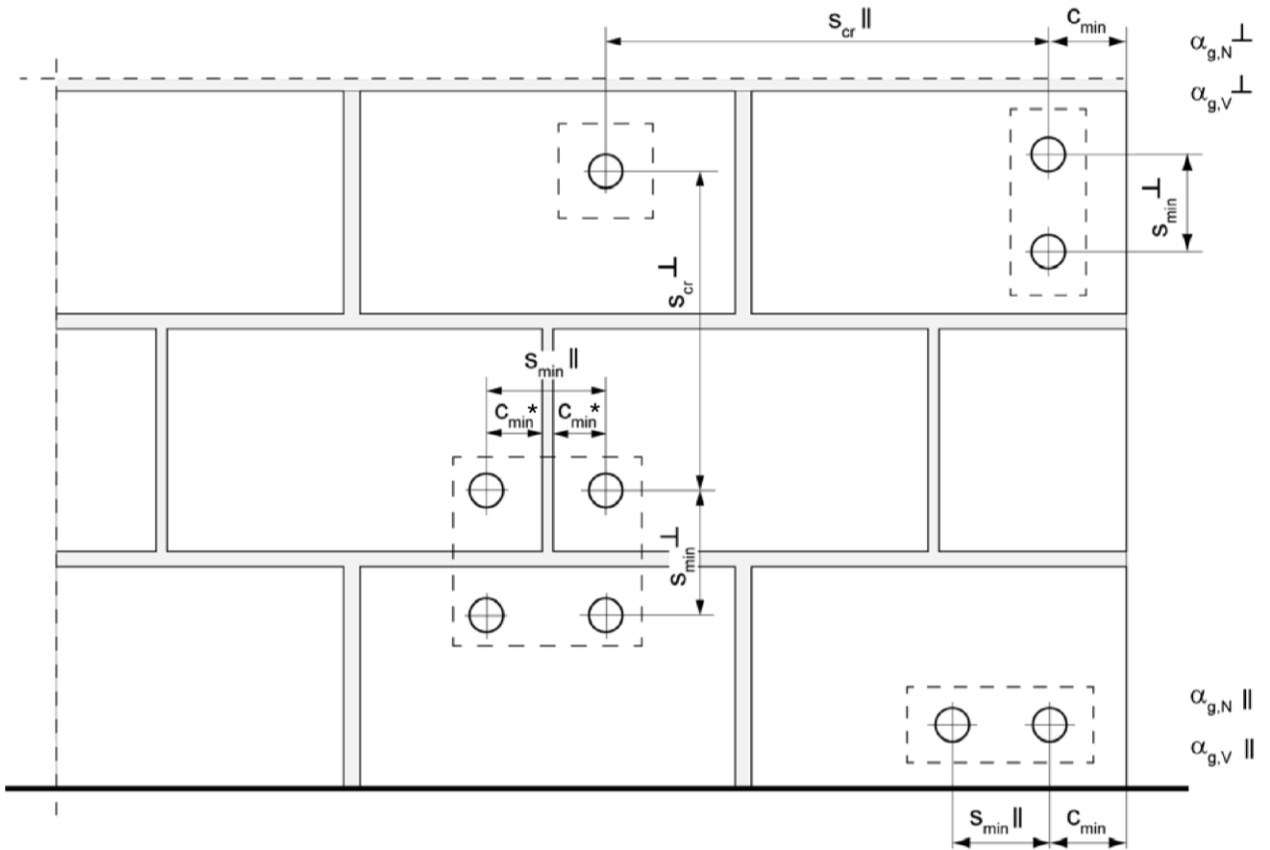

\* Only, if vertical joints are not completely filled with mortar

- $s_{min \parallel}$  = Minimum spacing parallel to bed joint
- $s_{min \perp}$  = Minimum spacing vertical to bed joint
- $s_{cr \parallel}$  = Characteristic spacing parallel to bed joint
- $s_{cr \perp}$  = Characteristic spacing vertical to bed joint
- $c_{cr} = c_{min}$  = Edge distance
- $\alpha_{g,N \parallel}$  = Group factor for tensile load, anchor group parallel to bed joint
- $\alpha_{g,V \parallel}$  = Group factor for shear load, anchor group parallel to bed joint
- $\alpha_{g,N \perp}$  = Group factor for tensile load, anchor group vertical to bed joint
- $\alpha_{g,V \perp}$  = Group factor for shear load, anchor group vertical to bed joint

For  $s \geq s_{cr}$   $\alpha_g = 2$

For  $s_{min} \leq s < s_{cr}$   $\alpha_g$  according to installation parameters of brick

$$N_{Rk}^g = \alpha_{g,N} \cdot N_{Rk}; \quad V_{Rk}^g = \alpha_{g,V} \cdot V_{Rk} \quad (\text{Group of 2 anchors})$$

$$N_{Rk}^g = \alpha_{g,N \parallel} \cdot \alpha_{g,N \perp} \cdot N_{Rk}; \quad V_{Rk}^g = \alpha_{g,V \parallel} \cdot \alpha_{g,V \perp} \cdot V_{Rk} \quad (\text{Group of 4 anchors})$$

fischer injektion system FIS V masonry

**Intended use**  
Spacing and edge distance

**Annex B 15**

<b>Table C1.1:</b> Characteristic values for the <b>steel bearing capacity of anchor rods</b> under tensile load									
<b>Anchor rod</b>			<b>M6</b>	<b>M8</b>	<b>M10</b>	<b>M12</b>	<b>M16</b>		
<b>Bearing capacity under tensile load, steel failure</b>									
Characteristic resistance $N_{Rk,s}$	Steel zinc plated	Property class	4.6	[kN]	8	15	23	34	63
			4.8		8	15	23	34	63
			5.8		10	18	29	42	78
			8.8		16	29	46	67	125
	Stainless steel A4 and High corrosion resistant steel C		50		10	18	29	42	78
			70		14	26	41	59	110
			80		16	29	46	67	125
			<b>Partial safety factors <sup>1)</sup></b>						
Partial safety factor $\gamma_{Ms,N}$	Steel zinc plated	Property class	4.6	[-]	2				
			4.8		1,5				
			5.8		1,50				
			8.8		1,50				
	Stainless steel A4 and High corrosion resistant steel C		50		2,86				
			70		1,50 <sup>2)</sup> / 1,87				
			80		1,60				
			<sup>1)</sup> In absence of other national regulations <sup>2)</sup> Only for fischer FIS A made of high corrosion-resistant steel C						
fischer injektion system FIS V masonry						<b>Annex C 1</b>			
<b>Performances</b> Characteristic steel bearing capacity of anchor rods									



<b>Table C2.1:</b> Characteristic values for the <b>steel bearing capacity</b> of <b>anchor rods</b> under shear load									
Anchor rod			M6	M8	M10	M12	M16		
<b>Bearing capacity under shear load, steel failure</b>									
<b>without lever arm</b>									
Characteristic resistance $V_{Rk,s}$	Steel zinc plated	Property class	4.6	[kN]	4	7	12	17	31
			4.8		4	7	12	17	31
			5.8		5	9	15	21	39
			8.8		8	15	23	34	63
	Stainless steel A4 and High corrosion resistant steel C	Property class	50		5	9	15	21	39
			70		7	13	20	30	55
			80		8	15	23	34	63
<b>with lever arm</b>									
Characteristic bending moment $M_{Rk,s}$	Steel zinc plated	Property class	4.6	[Nm]	6	15	30	52	133
			4.8		6	15	30	52	133
			5.8		8	19	37	65	166
			8.8		12	30	60	105	266
	Stainless steel A4 and High corrosion resistant steel C	Property class	50		7	19	37	65	166
			70		10	26	52	92	232
			80		12	30	60	105	266
<b>Partial safety factors<sup>1)</sup></b>									
Partial safety factor $\gamma_{Ms,V}$	Steel zinc plated	Property class	4.6	[-]	1,67				
			4.8		1,25				
			5.8		1,25				
			8.8		1,25				
	Stainless steel A4 and High corrosion resistant steel C		Property class		50	2,38			
					70	1,25 <sup>2)</sup> / 1,56			
					80	1,33			
<sup>1)</sup> In absence of other national regulations <sup>2)</sup> Only for fischer FIS A made of high corrosion-resistant steel C									
fischer injektion system FIS V masonry							<b>Annex C 2</b>		
<b>Performances</b> Characteristic steel bearing capacity of anchor rods									

<b>Table C3.1: Characteristic values for the steel bearing capacity of internal threaded anchors FIS E under tensile / shear load</b>								
<b>fischer internal threaded anchor FIS E</b>				<b>M6</b>	<b>M8</b>	<b>M10</b>	<b>M12</b>	
<b>Bearing capacity under tensile load, steel failure</b>								
Characteristic resistance with screw	$N_{Rk,s}$	Property class	5.8	[kN]	10	18	29	42
		Property class 70	A4		14	26	41	59
			C		14	26	41	59
<b>Partial safety factors<sup>1)</sup></b>								
Partial safety factor	$\gamma_{Ms,N}$	Property class	5.8	[-]	1,50			
		Property class 70	A4		1,87			
			C		1,87			
<b>Bearing capacity under shear load, steel failure</b>								
<b>without lever arm</b>								
Characteristic resistance with screw	$V_{Rk,s}$	Property class	5.8	[kN]	5	9	15	21
		Property class 70	A4		7	13	20	30
			C		7	13	20	30
<b>with lever arm</b>								
Characteristic bending moment	$M_{Rk,s}$	Property class	5.8	[Nm]	8	19	37	65
		Property class 70	A4		11	26	52	92
			C		11	26	52	92
<b>Partial safety factors<sup>1)</sup></b>								
Partial safety factor	$\gamma_{Ms,V}$	Property class	5.8	[-]	1,25			
		Property class 70	A4		1,56			
			C		1,56			
<sup>1)</sup> In absence of other national regulations								
fischer injektion system FIS V masonry							<b>Annex C 3</b>	
<b>Performances</b> Characteristic steel bearing capacity of fischer internal threaded anchor RG MI								

**Solid brick Mz, NF, EN 771-1**

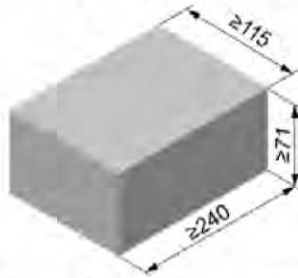

Solid brick Mz, NF, EN 771-1			
Producer	e.g. Wienerberger		
Nominal dimensions [mm]	length L	width W	height H
	≥ 240	≥ 115	≥ 71
Density $\rho$ [kg/dm <sup>3</sup> ]	≥ 1,8		
Compressive strength $f_b$ [N/mm <sup>2</sup> ]	12 / 20		
Standard or annex	EN 771-1		

**Table C4.1:** Installation parameters for edge distance  $c=100\text{mm}$

Anchor rod		M6	M8	M10	M12	-		-		
Internal threaded anchor FIS E		-	-	-	-	M6	M8	M10	M12	
						11x85		15x85		
<b>Anchor rod and internal threaded anchor FIS E without perforated sleeve</b>										
Effective anchorage depth	$h_{ef}$	[mm]	50	50	50	50	85			
			80	80	80	80				
			200	200	200	200				
Max. installation torque	$T_{inst,max}$	[Nm]	4	10			4	10		
<b>General installation parameters</b>										
Edge distance	$c_{min}$	[mm]	100				100			
Edge distance $h_{ef}=200$	$c_{min}$		150				-			
Spacing	$s_{min \parallel, N}$		60				60			
	$h_{ef}=200 s_{min \parallel, N}$		240				-			
	$s_{min \parallel, V}$		240				240			
	$s_{cr \parallel}$		240				240			
	$s_{cr \perp} = s_{min \perp}$		75				75			
<b>Drilling method</b>										
Hammer drilling with hard metal hammer drill										

**Table C4.2:** Group factors

Anchor rods		M6	M8	M10	M12	-		-	
Internal threaded anchor FIS E		-	-	-	-	M6	M8	M10	M12
						11x85		15x85	
Edge distance	$c_{min}$	[mm]	100						
Group factor	$\alpha_{g,N \parallel}$	[-]	1,5						
	$\alpha_{g,V \parallel}$		2,0						
	$h_{ef}=200 \alpha_{g,N \parallel}$		1,5						
	$h_{ef}=200 \alpha_{g,V \parallel}$		2,0						
	$\alpha_{g,N \perp}$		2,0						
	$\alpha_{g,V \perp}$		2,0						
	$h_{ef}=200 \alpha_{g,N \perp}$		2,0						
	$h_{ef}=200 \alpha_{g,V \perp}$		2,0						

fischer injektion system FIS V masonry

**Performances**  
Solid brick Mz, NF, dimensions, installation parameters  $c=100\text{mm}$

**Annex C 4**

**Solid brick Mz, NF, EN 771-1****Table C5.1:** Characteristic resistance under tensile load for edge distance 100mm

Anchor rod		M6	M8	M10			M12			-		-	
Internal threaded anchor FIS E		-	-	-			-			M6	M8	M10	M12
										11x85		15x85	
Tensile load $N_{Rk}$ [kN] depending on the compressive strength $f_b$ (temperature range 50/80°C)													
compressive strength $f_b$	Use categorie	Effective anchorage depth $h_{ef}$ [mm]											
		$\geq 50$	$\geq 50$	50	80	200	50	80	200	85			
12N/mm <sup>2</sup>	w/w   w/d	2,5	2,5	2	3	7,5	2	3,5	5	3,5			
	d/d	4	4	3,5	5	12	3	5,5	8	5,5			
20N/mm <sup>2</sup>	w/w   w/d	3,5	3,5	3	4,5	11	3	5	7	5			
	d/d	5,5	5,5	5	7	12	4,5	8	11,5	8			

Factor for temperature range 72/120°C: 0,83

**Table C5.2:** Characteristic resistance under shear load for edge distance 100mm

Anchor rod		M6	M8	M10			M12			-		-	
Internal threaded anchor FIS E		-	-	-			-			M6	M8	M10	M12
										11x85		15x85	
Shear load $V_{Rk}$ [kN] depending on the compressive strength $f_b$ (temperature range 50/80°C and 72/120°C)													
compressive strength $f_b$	Use categorie	Effective anchorage depth $h_{ef}$ [mm]											
		$\geq 50$	$\geq 50$	$\geq 50$	200	$\geq 50$	200	85					
12N/mm <sup>2</sup>	w/w   w/d	2,5	2,5	4	8,5	4	11,5	2,5					
	d/d												
20N/mm <sup>2</sup>	w/w   w/d	4,0	4,0	6	12	5,5	12	4					
	d/d												

Factor for job site tests and displacements see annex C110

fischer injektion system FIS V masonry

**Performances**

Solid brick Mz, NF, Characteristic resistance under tensile and shear load c=100mm

**Annex C 5**

<b>Solid brick Mz, NF, EN 771-1</b>											
<b>Table C6.1: Installation parameters for edge distance <math>c=60\text{mm}</math></b>											
<b>Anchor rod</b>		<b>M6</b>	<b>M8</b>	<b>M10</b>	<b>M12</b>	<b>M16</b>	-	-	-	-	
<b>Internal threaded anchor FIS E</b>		-	-	-	-	-	<b>M6</b>	<b>M8</b>	<b>M10</b>	<b>M12</b>	
							11x85		15x85		
<b>Anchor rod and internal threaded anchor FIS E without perforated sleeve</b>											
Effective anchorage depth $h_{ef}$	[mm]		50	50	50	50	50	85			
			100	100	100	100	100				
			200	200	200	200	200				
Max. installation torque $T_{inst,max}$	[Nm]	4	10				4	10			
<b>General installation parameters</b>											
Edge distance $c_{min}$						60					
Edge distance $h_{ef}=200$	$c_{min}$					60					
Spacing	$s_{min, II, N}$	[mm]					80				
	$h_{ef}=200$ $s_{min, II, N}$						80				
	$s_{min, II, V}$						80				
	$s_{cr, II}$						$3x h_{ef}$				
	$s_{min, \perp}$						80				
	$s_{cr, \perp}$						$3x h_{ef}$				
<b>Drilling method</b>											
Hammer drilling with hard metal hammer drill											
<b>Table C6.2: Group factors</b>											
<b>Anchor rods</b>		<b>M6</b>	<b>M8</b>	<b>M10</b>	<b>M12</b>	<b>M16</b>	-	-	-	-	
<b>Internal threaded anchor FIS E</b>		-	-	-	-	-	<b>M6</b>	<b>M8</b>	<b>M10</b>	<b>M12</b>	
							11x85		15x85		
Edge distance $c_{min}$	[mm]					60					
Group factor	$\alpha_{q, N, II}$	[-]					0,6				
	$\alpha_{q, V, II}$						1,3				
	$h_{ef}=200$ $\alpha_{q, N, II}$						1,4				
	$h_{ef}=200$ $\alpha_{q, V, II}$						1,5				
	$\alpha_{q, N, \perp}$						0,3				
	$\alpha_{q, V, \perp}$						1,3				
	$h_{ef}=200$ $\alpha_{q, N, \perp}$						2,0				
	$h_{ef}=200$ $\alpha_{q, V, \perp}$						1,1				
fischer injektion system FIS V masonry							<b>Annex C 6</b>				
<b>Performances</b> Solid brick Mz, NF, dimensions, installation parameters $c=60\text{mm}$											

**Solid brick Mz, NF, EN 771-1**

**Table C7.1:** Characteristic resistance under tensile load for edge distance  $c=60$  mm

Anchor rod		M6		M8		M10			M12			M16			-		-	
Internal threaded anchor FIS E		-		-		-			-			-			M6	M8	M10	M12
															11x85		15x85	
Tensile load $N_{Rk}$ [kN] depending on the compressive strength $f_b$ (temperature range 50/80°C)																		
compressive strength $f_b$	use category	Effective anchorage depth $h_{ef}$ [mm]																
		50	100	50	100	50	100	200	50	100	200	50	100	200	85			
12N/mm <sup>2</sup>	w/w   w/d	1,5	2,0	2,0	2,0	2,5	-	2,0	2,5	-	2,0	5,5	-	-				
	d/d	2,5	3,0	4,0	3,0	4,0	9,5	3,0	4,0	9,5	3,0	8,5	9,5	-				
20N/mm <sup>2</sup>	w/w   w/d	2,0	2,5	3,0	2,5	3,5	-	3,0	3,5	-	3,0	7,5	-	-				
	d/d	3,5	4,5	5,5	4,5	5,5	12	4,5	5,5	12	4,5	12	12	-				
28N/mm <sup>2</sup>	w/w   w/d	2,5	3,0	4,0	3,0	4,0	-	3,5	4,0	-	3,5	9,0	-	-				
	d/d	4,0	5,5	6,5	5,5	6,5	12	5,5	6,5	12	5,5	12	12	-				

Factor for temperature range 72/120°C: 0,83

**Table C7.2:** Characteristic resistance under shear load for edge distance  $c=60$  mm

Anchor rod		M6		M8		M10			M12			M16			-		-	
Internal threaded anchor FIS E		-		-		-			-			-			M6	M8	M10	M12
															11x85		15x85	
Shear load $V_{Rk}$ [kN] depending on the compressive strength $f_b$ (temperature range 50/80°C and 72/120°C)																		
compressive strength $f_b$	use category	Effective anchorage depth $h_{ef}$ [mm]																
		50	100	50	100	50	100	200	50	100	200	50	100	200	85			
12N/mm <sup>2</sup>	w/w   w/d	1,2	2,5	1,2	3,0	2,0	3,0	1,5	1,5	3,0	3,0	0,6	3,0	4,5	-			
	d/d	1,2	2,5	1,2	3,0	2,0	3,0	1,5	1,5	3,0	3,0	0,6	3,0	4,5	-			
20N/mm <sup>2</sup>	w/w   w/d	1,5	3,5	1,5	4,5	3,0	4,5	2,5	2,0	4,5	4,5	0,9	4,5	6,0	-			
	d/d	1,5	3,5	1,5	4,5	3,0	4,5	2,5	2,0	4,5	4,5	0,9	4,5	6,0	-			
28N/mm <sup>2</sup>	w/w   w/d	2,0	4,0	2,0	5,0	3,5	5,0	3,0	2,5	5,0	5,0	1,2	5,0	7,5	-			
	d/d	2,0	4,0	2,0	5,0	3,5	5,0	3,0	2,5	5,0	5,0	1,2	5,0	7,5	-			

Factor for job site tests and displacements see annex C110

fischer injektion system FIS V masonry

**Performances**

Solid brick Mz, NF, Characteristic resistance under tensile and shear load  $c=60$

**Annex C 7**

**Solid brick Mz, 2DF, EN 771-1**

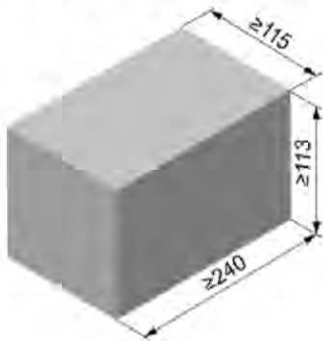

Solid brick Mz, 2DF, EN 771-1			
Producer	e.g. Wienerberger		
Nominal dimensions [mm]	length L	width W	height H
	≥ 240	≥ 115	≥ 113
Density $\rho$ [kg/dm <sup>3</sup> ]	≥ 1,8		
Compressive strength $f_b$ [N/mm <sup>2</sup> ]	10 / 16		
Standard or annex	EN 771-1		

**Table C8.1:** Installation parameters

Anchor rod	M6	M8	M10	M12	M16	-	-				
Internal threaded anchor FIS E	-	-	-	-	-	M6	M8	M10	M12		
	11x85		15x85								
<b>Anchor rod and internal threaded anchor FIS E without perforated sleeve</b>											
Effective anchorage depth $h_{ef}$ [mm]	50	100	50	100	50	100	50	100	50	100	85
Max. installation torque $T_{inst,max}$ [Nm]	4		10				4		10		
<b>Anchor rod and internal threaded anchor FIS E with perforated sleeve FIS H 16x85 K</b>											
Effective anchorage depth $h_{ef}$ [mm]	-		85				-		85		
Max. installation torque $T_{inst,max}$ [Nm]	-		10				-		4		10
<b>General installation parameters</b>											
Edge distance $c_{min}$	60										
Spacing	$s_{min} \parallel$	120									
	$s_{cr} \parallel$	240									
	$s_{cr} \perp = s_{min} \perp$	115									
<b>Drilling method</b>											
Hammer drilling with hard metal hammer drill											

**Table C8.2:** Group factors

Anchor rods	M6	M8	M10	M12	M16	-	-			
Internal threaded anchor FIS E	-	-	-	-	-	M6	M8	M10	M12	
	11x85		15x85							
Group factor	$\alpha_{q,N} \parallel$	1,5								
	$\alpha_{q,V} \parallel$	1,4								
	$\alpha_{q,N} \perp$	2								
	$\alpha_{q,V} \perp$	-								

fischer injektion system FIS V masonry

**Performances**  
Solid brick Mz, 2DF, dimensions, installation parameters

**Annex C 8**

**Solid brick Mz, 2DF, EN 771-1**

**Table C9.1:** Characteristic resistance under tensile load

Anchor rod	M6	M8	M10	M12	M16	-	-	M8	M10	-				
Internal threaded anchor FIS E	-	-	-	-	-	M6	M8	M10	M12	-	-	M6	M8	
						11x85		15x85				11x85		
Perforated sleeve FIS H K	-	-	-	-	-	-	-	16x85						
Tensile load $N_{Rk}$ [kN] depending on the compressive strength $f_b$ (temperature range 50/80°C)														
compressive strength $f_b$	use category	Effective anchorage depth $h_{ef}$ [mm]												
		50						85						
10N/mm <sup>2</sup>	w/w	1,5	2,5	1,5	2,5	1,5	3	2	3,5	2	3,5	2		1,5
	d/d	3	4,0	3,0	4,0	3,0	4,5	3	5,5	3	5,5	3		3
16N/mm <sup>2</sup>	w/w	2,5	4	2,5	4	2,5	4,5	3,5	5,5	3,5	5,5	3,5		2,5
	d/d	4,5	7,0	4,5	7,0	4,5	7,5	5,5	8	5,5	8	5,5		4,5

Factor for temperature range 72/120°C: 0,83

**Table C9.2:** Characteristic resistance under shear load

Anchor rod	M6	M8	M10	M12	M16	-	-	M8	M10	-				
Internal threaded anchor FIS E	-	-	-	-	-	M6	M8	M10	M12	-	-	M6	M8	
						11x85		15x85				11x85		
Perforated sleeve FIS H K	-	-	-	-	-	-	-	16x85						
Shear load $V_{Rk}$ [kN] depending on the compressive strength $f_b$ (temperature range 50/80°C and 72/120°C)														
compressive strength $f_b$	use category	Effective anchorage depth $h_{ef}$ [mm]												
		≥ 50						85						
10N/mm <sup>2</sup>	w/w	2,5	3,0	3,0	3,5	3,0	2,5	3,0	3,0	3,0	3,0	3,0	3,5	2,5
	d/d													
16N/mm <sup>2</sup>	w/w	4,0	5,0	5,5	5,5	5,0	4,0	5,0	5,0	5,0	5,0	5,0	6,0	4,0
	d/d													

Factor for job site tests and displacements see annex C110

fischer injektion system FIS V masonry

**Performances**

Solid brick Mz, 2DF, Characteristic resistance under tensile and shear load

**Annex C 9**



**Solid brick Mz, EN 771-1**

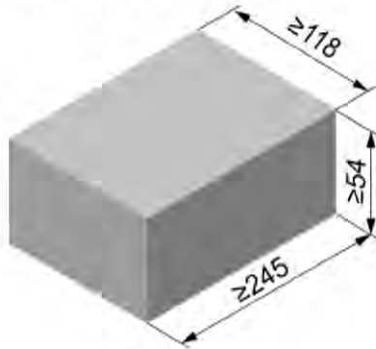

Solid brick Mz, EN 771-1			
Producer	e.g. Nigra		
Nominal dimensions [mm]	length L	width W	height H
	≥ 245	≥ 118	≥ 54
Density $\rho$ [kg/dm <sup>3</sup> ]	≥ 1,8		
Compressive strength $f_b$ [N/mm <sup>2</sup> ]	10 / 20		
Standard or annex	EN 771-1		

**Table C10.1:** Installation parameters

Anchor rod	M6	M8	M10	M12	M16	-	-		
Internal threaded anchor FIS E	-	-	-	-		M6	M8	M10	M12
						11x85		15x85	
<b>Anchor rod and internal threaded anchor FIS E without perforated sleeve</b>									
Effective anchorage depth $h_{ef}$ [mm]	50	100	50	100	50	100	50	100	85
Max. installation torque $T_{inst,max}$ [Nm]	4	10					4	10	
<b>General installation parameters</b>									
Edge distance $c_{min}$					60				
Spacing	$s_{cr \parallel} = s_{min \parallel}$ [mm]				245				
	$s_{cr \perp} = s_{min \perp}$				60				
<b>Drilling method</b>									
Hammer drilling with hard metal hammer drill									

**Table C10.2:** Group factors

Anchor rods	M6	M8	M10	M12	M16	-	-			
Internal threaded anchor FIS E	-	-	-	-	-	M6	M8	M10	M12	
						11x85		15x85		
Group factor	$\alpha_{g,N \parallel}$	[-]								
	$\alpha_{g,V \parallel}$									
	$\alpha_{g,N \perp}$									
	$\alpha_{g,V \perp}$						2			

fischer injektion system FIS V masonry

**Performances**  
Solid brick Mz, dimensions, installation parameters

**Annex C 10**

**Solid brick Mz, EN 771-1****Table C11.1:** Characteristic resistance under tensile load

Anchor rod		M6	M8	M10	M12	M16	-		-	
Internal threaded anchor FIS E		-	-	-	-	-	M6	M8	M10	M12
				11x85		15x85				
Tensile load $N_{Rk}$ [kN] depending on the compressive strength $f_b$ (temperature range 50/80°C)										
compressive strength $f_b$	use category	Effective anchorage depth $h_{ef}$ [mm]								
		≥ 50						85		
10N/mm <sup>2</sup>	w/w	w/d	0,6	0,9	0,75	0,75	0,75	0,6	0,75	
	d/d		1,2	1,5	1,2	1,2	1,2	1,2	1,2	1,2
20N/mm <sup>2</sup>	w/w	w/d	0,9	1,5	1,2	1,2	1,2	0,9	1,2	
	d/d		1,5	2,5	2,0	2,0	2,0	1,5	2,0	

Factor for temperature range 72/120°C: 0,83

**Table C11.2:** Characteristic resistance under shear load

Anchor rod		M6	M8	M10	M12	M16	-		-		
Internal threaded anchor FIS E		-	-	-	-	-	M6	M8	M10	M12	
				11x85		15x85					
Shear load $V_{Rk}$ [kN] depending on the compressive strength $f_b$ (temperature range 50/80°C and 72/120°C)											
compressive strength $f_b$	use category	Effective anchorage depth $h_{ef}$ [mm]									
		≥ 50						85			
10N/mm <sup>2</sup>	w/w	w/d	2,0	3,0	4,0	4,5	5,5	2,0	3,0	4,0	4,5
	d/d										
20N/mm <sup>2</sup>	w/w	w/d	2,5	4,0	5,5	6,0	8,0	2,5	4,0	5,5	6,0
	d/d										

Factor for job site tests and displacements see annex C110

fischer injektion system FIS V masonry

**Performances**

Solid brick Mz, Characteristic resistance under tensile and shear load

**Annex C 11**

**Solid brick Mz, EN 771-1**

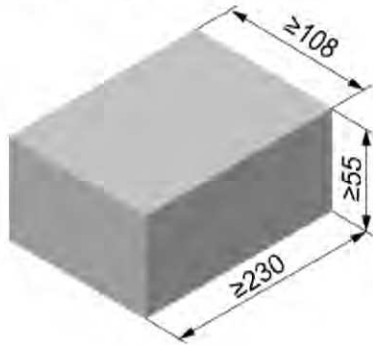

Solid brick Mz, EN 771-1			
Producer	e.g. Wienerberger		
Nominal dimensions [mm]	length L	width W	height H
	≥ 230	≥ 108	≥ 55
Density $\rho$ [kg/dm <sup>3</sup> ]	≥ 1,8		
Compressive strength $f_b$ [N/mm <sup>2</sup> ]	10 / 20		
Standard or annex	EN 771-1		

**Table C12.1:** Installation parameters

Anchor rod	M6	M8	M10	M12	M16	-	-		
Internal threaded anchor FIS E	-	-	-	-	-	M6	M8	M10	M12
							11x85		15x85
<b>Anchor rod and internal threaded anchor FIS E without perforated sleeve</b>									
Effective anchorage depth $h_{ef}$ [mm]	50	90	50	90	50	90	50	90	85
Max. installation torque $T_{inst,max}$ [Nm]	4		10				4		10
<b>General installation parameters</b>									
Edge distance $c_{min}$					60				
Spacing	$s_{cr \parallel} = s_{min \parallel}$ [mm]						230		
	$s_{cr \perp} = s_{min \perp}$						60		
<b>Drilling method</b>									
Hammer drilling with hard metal hammer drill									

**Table C12.2:** Group factors

Anchor rods	M6	M8	M10	M12	M16	-	-			
Internal threaded anchor FIS E	-	-	-	-	-	M6	M8	M10	M12	
							11x85		15x85	
Group factor	$\alpha_{g,N \parallel}$	[-]					2			
	$\alpha_{g,V \parallel}$									
	$\alpha_{g,N \perp}$									
	$\alpha_{g,V \perp}$									

fischer injektion system FIS V masonry

**Performances**  
Solid brick Mz, dimensions, installation parameters

**Annex C 12**

**Solid brick Mz, EN 771-1****Table C13.1:** Characteristic resistance under tensile load

Anchor rod		M6	M8	M10	M12	M16	-	-		
Internal threaded anchor FIS E		-	-	-	-	-	M6	M8	M10	M12
							11x85		15x85	
Tensile load $N_{Rk}$ [kN] depending on the compressive strength $f_b$ (temperature range 50/80°C)										
compressive strength $f_b$	use category	Effective anchorage depth $h_{ef}$ [mm]								
		≥ 50							85	
10N/mm <sup>2</sup>	w/w	0,6	0,9	0,75	0,75	0,75				0,75
	d/d	1,2	1,5	1,2	1,2	1,2				1,2
20N/mm <sup>2</sup>	w/w	0,9	1,5	1,2	1,2	1,2				1,2
	d/d	1,5	2,5	2,0	2,0	2,0				2,0

Factor for temperature range 72/120°C: 0,83

**Table C13.2:** Characteristic resistance under shear load

Anchor rod		M6	M8	M10	M12	M16	-	-		
Internal threaded anchor FIS E		-	-	-	-	-	M6	M8	M10	M12
							11x85		15x85	
Querlast $V_{Rk}$ [kN] in Abhängigkeit von der Druckfestigkeit $f_b$ (Temperaturbereich 50/80°C und 72/120°C)										
compressive strength $f_b$	use category	Effective anchorage depth $h_{ef}$ [mm]								
		≥ 50							85	
10N/mm <sup>2</sup>	w/w	2,0	3,0	4,0	4,5	5,5	2,0	3,0	4,0	4,5
	d/d									
20N/mm <sup>2</sup>	w/w	2,5	4,0	5,5	6,0	8,0	2,5	4,0	5,5	6,0
	d/d									

Factor for job site tests and displacements see annex C110

fischer injektion system FIS V masonry

**Performances**

Solid brick Mz, Characteristic resistance under tensile and shear load

**Annex C 13**

**Solid sand-lime brick KS, NF, EN 771-2**

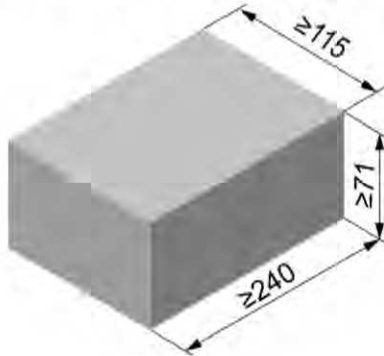

Solid sand-lime brick KS, NF, EN 771-2			
Producer			
Nominal dimensions [mm]	length L	width W	height H
	≥ 240	≥ 115	≥ 71
Density $\rho$ [kg/dm <sup>3</sup> ]			
Compressive strength $f_b$ [N/mm <sup>2</sup> ]	12 / 20 / 28		
Standard or annex	EN 771-2		

**Table C14.1:** Installation parameters

Anchor rod	M6	M8	M10	M12	M16	-		-		
Internal threaded anchor FIS E	-	-	-	-	-	M6	M8	M10	M12	
	11x85		15x85							
<b>Anchor rod and internal threaded anchor FIS E without perforated sleeve</b>										
Effective anchorage depth $h_{ef}$ [mm]	50	100	50	100	50	100	85		85	
	200		200		200					
Max. installation torque $T_{inst,max}$ [Nm]	3	5	15	15	25	3	5	15		
<b>General installation parameters</b>										
Edge distance $c_{min}$					60					
Spacing	$s_{min} \parallel$					80				
	$s_{cr} \parallel$ [mm]					80				
	$s_{min} \perp$					3x $h_{ef}$				
	$s_{cr} \perp$					3x $h_{ef}$				
	<b>Drilling method</b>									
Hammer drilling with hard metal hammer drill										

**Table C14.2:** Group factors

Anchor rod	M6	M8	M10	M12	M16	-		-		
Internal threaded anchor FIS E	-	-	-	-	-	M6	M8	M10	M12	
	11x85		15x85							
Group factor	$\alpha_{q,N} \parallel$					0,7				
	$\alpha_{q,V} \parallel$					1,3				
	$\alpha_{q,N} \perp$					2,0				
	$\alpha_{q,V} \perp$					2,0				

fischer injektion system FIS V masonry

**Performances**  
Solid sand-lime brick KS, NF, dimensions, installation parameters

**Annex C 14**

**Solid sand-lime brick KS, NF, EN 771-2****Table C15.1:** Characteristic resistance under tensile load

Anchor rod		M6		M8		M10			M12			M16			-		-	
Internal threaded anchor FIS E		-		-		-			-			-			M6	M8	M10	M12
															11x85		15x85	
Tensile load $N_{Rk}$ [kN] depending on the compressive strength $f_b$ (temperature range 50/80°C)																		
compressive strength $f_b$	use category		Effective anchorage depth $h_{ef}$ [mm]															
	w/w	w/d	50	100	50	100	50	100	200	50	100	200	50	100	200	85	85	
12N/mm <sup>2</sup>	w/w	w/d	2,0	3,0	2,5	4,5	2,5	3,5	7,0	2,5	3,0	6,5	2,5	3,5	8,0	2,5	2,5	
	d/d	d/d	4,0	5,5	4,0	8,0	4,0	5,5	12	4,0	4,5	12	4,5	5,5	12	4,0	4,0	
20N/mm <sup>2</sup>	w/w	w/d	3,0	4,5	3,5	6,5	3,5	4,5	10	3,5	4,0	9,5	4,0	5,0	11	3,5	3,5	
	d/d	d/d	5,5	7,5	6,0	11	6,0	8,0	12	6,0	6,5	12	6,5	8,0	12	6,0	6,0	
28N/mm <sup>2</sup>	w/w	w/d	3,5	5,0	4,0	8,0	4,5	5,5	12	4,5	5,0	11	4,5	5,5	12	4,5	4,5	
	d/d	d/d	6,5	9,0	7,0	12	7,0	9,0	12	7,0	7,5	12	7,5	9,5	12	7,0	7,0	

Factor for temperature range 72/120°C: 0,83

**Table C15.2:** Characteristic resistance under shear load

Anchor rod		M6		M8		M10			M12			M16			-		-	
Internal threaded anchor FIS E		-		-		-			-			-			M6	M8	M10	M12
															11x85		15x85	
Shear load $V_{Rk}$ [kN] depending on the compressive strength $f_b$ (temperature range 50/80°C and 72/120°C)																		
compressive strength $f_b$	use category		Effective anchorage depth $h_{ef}$ [mm]															
	w/w	w/d	50	100	50	100	50	≥100	50	≥100	50	≥100	85	85				
12N/mm <sup>2</sup>	w/w	w/d	1,5	3,0	1,5	3,0	1,2	2,0	1,2	2,0	1,2	2,0	1,2	1,2				
	d/d	d/d	1,5	3,0	1,5	3,0	1,2	2,0	1,2	2,0	1,2	2,0	1,2	1,2				
20N/mm <sup>2</sup>	w/w	w/d	2,5	4,0	2,5	4,0	1,5	3,0	1,5	3,0	1,5	3,0	1,5	1,5				
	d/d	d/d	2,5	4,0	2,5	4,0	1,5	3,0	1,5	3,0	1,5	3,0	1,5	1,5				
28N/mm <sup>2</sup>	w/w	w/d	3,0	4,5	3,0	4,5	1,5	3,5	1,5	3,5	1,5	3,5	1,5	1,5				
	d/d	d/d	3,0	4,5	3,0	4,5	1,5	3,5	1,5	3,5	1,5	3,5	1,5	1,5				

Factor for job site tests and displacements see annex C110

fischer injektion system FIS V masonry

**Performances**

Solid sand-lime brick KS, NF, Characteristic resistance under tensile and shear load

**Annex C 15**

**Solid sand-lime brick KS, 8DF, EN 771-2**

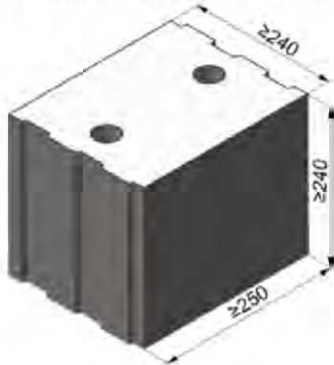

Solid sand-lime brick KS, 8DF, EN 771-2			
Producer	-		
Nominal dimensions [mm]	length L	width W	height H
	≥ 250	≥ 240	≥ 240
Density $\rho$ [kg/dm <sup>3</sup> ]	≥ 2,0		
Compressive strength $f_b$ [N/mm <sup>2</sup> ]	10 / 20 / 28		
Standard or annex	EN 771-2		

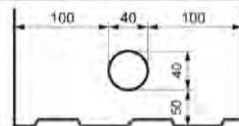

**Table C16.1:** Installation parameters

Anchor rod	M6	M8	M10	M12	M16	-	-				
Internal threaded anchor FIS E	-	-	-	-	-	M6	M8	M10	M12		
	11x85		15x85								
<b>Anchor rod and internal threaded anchor FIS E without perforated sleeve</b>											
Effective anchorage depth $h_{ef}$ [mm]	50	100	50	100	50	100	50	100	50	100	85
Max. installation torque $T_{inst,max}$ [Nm]	4		10				4		10		
<b>Anchor rod and internal threaded anchor FIS E with perforated sleeve FIS H 16x85 K</b>											
Effective anchorage depth $h_{ef}$ [mm]			85						85		
Max. installation torque $T_{inst,max}$ [Nm]			10						4		10
<b>General installation parameters</b>											
Edge distance $c_{min}$					60						
Spacing	$s_{min} \parallel$					80					
	$s_{cr} \parallel$					250					
	$s_{min} \perp$					80					
	$s_{cr} \perp$					240					
	<b>Drilling method</b>										
Hammer drilling with hard metal hammer drill											

**Table C16.2:** Group factors

Anchor rods	M6	M8	M10	M12	M16	-	-			
Internal threaded anchor FIS E	-	-	-	-	-	M6	M8	M10	M12	
	11x85		15x85							
Group factors	$\alpha_{q,N} \parallel$					1,5				
	$\alpha_{q,V} \parallel$					1,2				
	$\alpha_{q,N} \perp$					1,5				
	$\alpha_{q,V} \perp$					1,2				

fischer injektion system FIS V masonry

**Performances**

Solid sand-lime brick KS, 8DF, dimensions, installation parameters

**Annex C 16**

**Solid sand-lime brick KS, 8DF, EN 771-2****Table C17.1:** Characteristic resistance under tensile load

Anchor rod	M6	M8	M10	M12	M16	-		-		M8	M10	-		
Internal threaded anchor FIS E	-	-	-	-	-	M6	M8	M10	M12	-	-	M6	M8	
						11x85		15x85		11x85				
Perforated sleeve FIS H K	-												16x85	
Tensile load $N_{Rk}$ [kN] depending on the compressive strength $f_b$ (temperature range 50/80°C)														
compressive strength $f_b$	use category	Effective anchorage depth $h_{ef}$ [mm]												
		≥ 50						85						
10N/mm <sup>2</sup>	w/w	w/d	3,0	4,0	4,5	4,5	3,5	3,0	3,5	4,5	3,0	4,5		
	d/d	5,0	7,0	7,0	7,0	5,5	5,0	5,5	8,0	5,0	8,0			
20N/mm <sup>2</sup>	w/w	w/d	4,5	6,0	6,0	6,0	5,0	4,5	5,0	6,5	4,5	6,5		
	d/d	7,5	10,0	10,0	10,0	7,5	7,5	7,5	11,0	7,5	11,0			
28N/mm <sup>2</sup>	w/w	w/d	5,0	8,0	8,5	8,5	7,0	5,0	7,0	8,5	5,0	8,5		
	d/d	8,5	12,0	12,0	12,0	11,0	8,5	11,0	12,0	8,5	12,0			

Factor for temperature range 72/120°C: 0,83

**Table C17.2:** Characteristic resistance under shear load

Anchor rod	M6	M8	M10	M12	M16	-		-		M8	M10	-		
Internal threaded anchor FIS E	-	-	-	-	-	M6	M8	M10	M12	-	-	M6	M8	
						11x85		15x85		11x85				
Perforated sleeve FIS H K	-												16x85	
Shear load $V_{Rk}$ [kN] depending on the compressive strength $f_b$ (temperature range 50/80°C and 72/120°C)														
compressive strength $f_b$	use category	Effective anchorage depth $h_{ef}$ [mm]												
		≥ 50						85						
10N/mm <sup>2</sup>	w/w	w/d	2,5	4,5			2,5	4,5	4,5	2,5	4,5			
	d/d													
20N/mm <sup>2</sup>	w/w	w/d	4,0	6,5			4,0	6,5	6,5	4,0	6,5			
	d/d													
28N/mm <sup>2</sup>	w/w	w/d	5,0	9,0			5,0	9,0	9,0	5,0	9,0			
	d/d													

Factor for job site tests and displacements see annex C110

fischer injektion system FIS V masonry

**Performances**

Solid sand-lime brick KS, 8DF, Characteristic resistance under tensile and shear load

**Annex C 17**



**Solid sand-lime brick KS, EN 771-2**

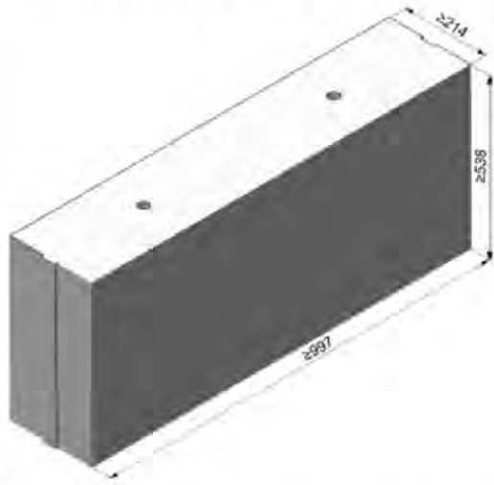

Solid sand-lime brick KS, EN 771-2			
Producer	e.g. Calduran		
Nominal dimensions [mm]	length L	width W	height H
	≥ 997	≥ 214	≥ 538
Density $\rho$ [kg/dm <sup>3</sup> ]	1,8		2,2
Compressive strength $f_b$ [N/mm <sup>2</sup> ]	10 / 20		36
Standard or annex	EN 771-2		



**Table C18.1:** Installation parameters

Anchor rod	M6	M8	M10	M12	M16	-	-		
Internal threaded anchor FIS E	-	-	-	-	-	M6	M8	M10	M12
					11x85		15x85		
<b>Anchor rod and internal threaded anchor FIS E without perforated sleeve</b>									
Effective anchorage depth $h_{ef}$ [mm]	50	100	50	100	50	100	50	100	85
Max. installation torque $T_{inst,max}$ [Nm]	4		10				4	10	
<b>General installation parameters</b>									
Edge distance $c_{min}$						75			
Spacing $s_{cr}$	$s_{cr} \parallel = s_{min} \parallel$					3x $h_{ef}$			
	$s_{cr} \perp = s_{min} \perp$					3x $h_{ef}$			
<b>Drilling method</b>									
Hammer drilling with hard metal hammer drill									

**Table C18.2:** Group factors

Anchor rod	M6	M8	M10	M12	M16	-	-			
Internal threaded anchor FIS E	-	-	-	-	-	M6	M8	M10	M12	
					11x85		15x85			
Group factors	$\alpha_{a,N} \parallel$	[-]								
	$\alpha_{a,V} \parallel$									
	$\alpha_{a,N} \perp$									
	$\alpha_{a,V} \perp$						2			

fischer injektion system FIS V masonry

**Performances**  
Solid sand-lime brick KS, dimensions, installation parameters

**Annex C 18**

**Solid sand-lime brick KS, EN 771-2****Table C19.1:** Characteristic resistance under tensile load

Anchor rod		M6	M8	M10	M12	M16	-		-			
Internal threaded anchor FIS E		-		-		-		-		-		
		-		-		-		-		M6	M8	M10
		11x85		15x85								
Tensile load $N_{Rk}$ [kN] depending on the compressive strength $f_b$ (temperature range 50/80°C)												
compressive strength $f_b$	use category	Effective anchorage depth $h_{ef}$ [mm]										
		50	100	50	100	50	100	50	100	50	100	85
10N/mm <sup>2</sup>	w/w	4,0	4,0	7,0	5,0	6,0	5,0	6,0	5,5	7,5	5,5	
	d/d	7,0	7,0	12,0	8,0	9,5	8,0	10,0	9,0	11,5	9,0	
20N/mm <sup>2</sup>	w/w	5,5	6,0	10,0	7,0	8,5	7,0	9,0	8,0	11,0	8,0	
	d/d	8,5	10,5	12,0	11,5	12,0	11,0	12,0	12,0	12,0	12,0	
36N/mm <sup>2</sup>	w/w	4,5	8,0	12,0	11,5	12,0	12,0	12,0	12,0	12,0	12,0	
	d/d	8,0	12,0	12,0	12,0	12,0	12,0	12,0	12,0	12,0	12,0	

Factor for temperature range 72/120°C: 0,83

**Table C19.2:** Characteristic resistance under shear load

Anchor rod		M6	M8	M10	M12	M16	-		-			
Internal threaded anchor FIS E		-		-		-		-		-		
		-		-		-		-		M6	M8	M10
		11x85		15x85								
Shear load $V_{Rk}$ [kN] depending on the compressive strength $f_b$ (temperature range 50/80°C and 72/120°C)												
compressive strength $f_b$	use category	Effective anchorage depth $h_{ef}$ [mm]										
		≥ 50									85	
10N/mm <sup>2</sup>	w/w	3,0	5,0	5,5	4,0	4,0	3,0	5,0	5,5	4,0		
	d/d	3,0	5,0	5,5	4,0	4,0	3,0	5,0	5,5	4,0		
20N/mm <sup>2</sup>	w/w	4,5	7,0	7,5	6,0	6,0	4,5	7,0	7,5	6,0		
	d/d	4,5	7,0	7,5	6,0	6,0	4,5	7,0	7,5	6,0		
36N/mm <sup>2</sup>	w/w	4,5	9,0	11,0	12,0	12,0	4,5	9,0	11,0	12,0		
	d/d	4,5	9,0	11,0	12,0	12,0	4,5	9,0	11,0	12,0		

Factor for job site tests and displacements see annex C110

fischer injektion system FIS V masonry

**Performances**

Solid sand-lime brick KS, Characteristic resistance under tensile and shear load

**Annex C 19**

**Perforated sand-lime brick KSL, 3DF, EN 771-2**

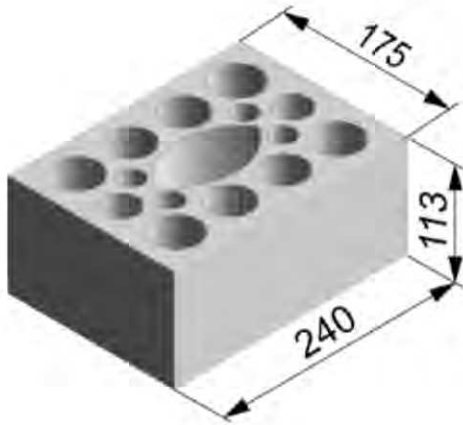

Perforated sand-lime brick KSL, 3DF, EN 771-2			
Producer	e.g. KS Wemding		
Nominal dimensions [mm]	length L	width W	height H
	240	175	113
Density $\rho$ [kg/dm <sup>3</sup> ]	≥ 1,4		
Compressive strength $f_b$ [N/mm <sup>2</sup> ]	8 / 10 / 12 / 16 / 20		
Standard or annex	EN 771-2		

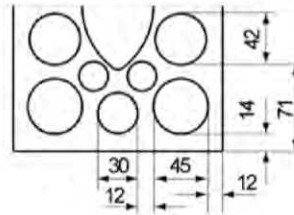

**Tabelle C20.1:** Installation parameters  
(Pre-positioned anchorage with perforated sleeve FIS HK)

Anchor rod	M6	M8	M6	M8	-	M8	M10	M8	M10	-	M12	M16	M12	M16
Internal threaded anchor FIS E	-	-	-	-	M6   M8 11x85	-	-	-	-	M10   M12 15x85	-	-	-	-
Perforated sleeve FIS H K	12x50		12x85		16x85			16x130		20x85			20x130	
<b>Anchor rod and internal threaded anchor FIS E with perforated sleeve FIS HK</b>														
Max. installation torque $T_{inst,max}$ [Nm]	2													
<b>General installation parameters</b>														
Edge distance $c_{min}$	60				80									
Spacing	$s_{min} \parallel$	100												
	$s_{cr} \parallel$	240												
	$s_{min} \perp$	115												
	$s_{cr} \perp$	115												
<b>Drilling method</b>														
Hammer drilling with hard metal hammer drill														

**Table C20.2:** Group factors

Anchor rod	M6	M8	M6	M8	-	M8	M10	M8	M10	-	M12	M16	M12	M16
Internal threaded anchor FIS E	-	-	-	-	M6   M8 11x85	-	-	-	-	M10   M12 15x85	-	-	-	-
Perforated sleeve FIS H K	12x50		12x85		16x85			16x130		20x85			20x130	
Group factors $\frac{\alpha_{q,N} \parallel = \alpha_{q,V} \parallel}{\alpha_{q,N} \perp = \alpha_{q,V} \perp}$ [-]	1,5													
	2,0													

fischer injektion system FIS V masonry

**Performances**  
Perforated sand-lime brick KSL, 3DF, dimensions, installation parameters

**Annex C 20**

**Perforated sand-lime brick KSL, 3DF, EN 771-2****Table C21.1:** Installation parameters  
(Push through anchorage with perforated sleeve FIS HK)

Anchor rod		M10	M12	M16
Perforated sleeve FIS H K		18x130/200		22x130/200
<b>Anchor rod with perforated sleeve FIS H K</b>				
Max. installation torque	$T_{inst,max}$ [Nm]	2		
<b>General installation parameters</b>				
Edge distance	$c_{min}$	80		
Spacing	$s_{min} \parallel$	100		
	$s_{cr} \parallel$	240		
	$s_{min} \perp$	115		
	$s_{cr} \perp$	115		
<b>Drilling method</b>				
Hammer drilling with hard metal hammer drill				

**Table C21.2:** Group factors

Anchor rod		M10	M12	M16
Perforated sleeve FIS H K		18x130/200		22x130/200
Group factors	$\alpha_{a,N} \parallel$	[-]	1,5	
	$\alpha_{a,V} \parallel$			
	$\alpha_{a,N} \perp$		2,0	
	$\alpha_{a,V} \perp$			

fischer injektion system FIS V masonry

**Performances**  
Perforated sand-lime brick KSL, 3DF, dimensions, installation parameters**Annex C 21**

**Perforated sand-lime brick KSL, 3DF, EN 771-2****Table C22.1:** Characteristic resistance under tensile load (Pre-positioned anchorage)

Anchor rod	M6	M8	M6	M8	-	M8	M10	M8	M10	-	M12	M16	M12	M16	
Internal threaded anchor FIS E	-	-	-	-	M6	M8	-	-	-	M10	M12	-	-	-	
					11x85					15x85					
Perforated sleeve FIS H K	12x50		12x85		16x85			16x130		20x85			20x130		
<b>Tensile load <math>N_{Rk}</math> [kN] depending on the compressive strength <math>f_b</math> (temperature range 50/80°C)</b>															
compressive strength $f_b$	use category														
8 N/mm <sup>2</sup>	w/w	w/d	1,5			2,0			2,0		2,0			2,0	
	d/d		1,5			2,0			2,5		2,5			2,5	
10 N/mm <sup>2</sup>	w/w	w/d	2,0			2,0			2,5		2,5			2,5	
	d/d		2,0			2,5			3,0		3,0			3,0	
12 N/mm <sup>2</sup>	w/w	w/d	2,5			2,5			3,0		3,0			3,0	
	d/d		2,5			3,0			3,5		3,5			3,5	
16 N/mm <sup>2</sup>	w/w	w/d	3,0			3,5			4,5		4,5			4,5	
	d/d		3,5			4,0			4,5		4,5			4,5	
20 N/mm <sup>2</sup>	w/w	w/d	4,0			4,5			5,5		5,5			5,5	
	d/d		4,5			5,0			6,0		6,0			6,0	

**Table C22.2:** Characteristic resistance under tensile load (Push through anchorage)

Anchor rod	M10		M12		M16	
Perforated sleeve FIS H K	18x130/200				22x130/200	
<b>Tensile load <math>N_{Rk}</math> [kN] depending on the compressive strength <math>f_b</math> (temperature range 50/80°C)</b>						
compressive strength $f_b$	use category					
8 N/mm <sup>2</sup>	w/w	w/d	2,0			
	d/d		2,5			
10 N/mm <sup>2</sup>	w/w	w/d	2,5			
	d/d		3,0			
12 N/mm <sup>2</sup>	w/w	w/d	3,0			
	d/d		3,5			
16 N/mm <sup>2</sup>	w/w	w/d	4,5			
	d/d		4,5			
20 N/mm <sup>2</sup>	w/w	w/d	5,5			
	d/d		6,0			

Factor for job site tests and displacements see annex C110

Factor for temperature range 72/120°C: 0,83

fischer injektion system FIS V masonry

**Performances**  
Perforated sand-lime brick KSL, 3DF, Characteristic resistance under tensile load

**Annex C 22**

**Perforated sand-lime brick KSL, 3DF, EN 771-2****Table C23.1:** Characteristic resistance under shear load (Pre-positioned anchorage)

Anchor rod	M6	M8	M6	M8	-	M8	M10	M8	M10	-	M12	M16	M12	M16			
Internal threaded anchor FIS E	-	-	M6	M8	11x85	-	-	-	-	M10	M12	-	-	-			
Perforated sleeve FIS H K	12x50	12x85	16x85			16x130			20x85			20x130					
<b>Shear load <math>V_{RK}</math> [kN] depending on the compressive strength <math>f_b</math> (temperature range 50/80°C and 72/120°C)</b>																	
compressive strength $f_b$	use category																
8 N/mm <sup>2</sup>	w/w	w/d	1,5						3,0						2,5	3,0	2,5
	d/d																
10 N/mm <sup>2</sup>	w/w	w/d	2,0						3,5								
	d/d																
12 N/mm <sup>2</sup>	w/w	w/d	2,5						4,5						4,0	4,5	4,0
	d/d																
16 N/mm <sup>2</sup>	w/w	w/d	3,0	3,5	3,0	3,5	3,0	6,0						5,5	6,0	5,5	
	d/d																
20 N/mm <sup>2</sup>	w/w	w/d	4,0	4,5	4,0	4,5	4,0	7,5						6,5	7,5	6,5	
	d/d																

**Table C23.2:** Characteristic resistance under shear load (Push through anchorage)

Anchor rod	M10			M12			M16				
Perforated sleeve FIS H K	18x130/200						22x130/200				
<b>Shear load <math>V_{RK}</math> [kN] depending on the compressive strength <math>f_b</math> (temperature range 50/80°C and 72/120°C)</b>											
compressive strength $f_b$	use category										
8 N/mm <sup>2</sup>	w/w	w/d	3,0						2,5		
	d/d										
10 N/mm <sup>2</sup>	w/w	w/d	3,5						3,5		
	d/d										
12 N/mm <sup>2</sup>	w/w	w/d	4,5						4,0		
	d/d										
16 N/mm <sup>2</sup>	w/w	w/d	6,0						5,5		
	d/d										
20 N/mm <sup>2</sup>	w/w	w/d	7,5						6,5		
	d/d										

Factor for job site tests and displacements see annex C110

fischer injektion system FIS V masonry

**Performances**

Perforated sand-lime brick KSL, 3DF, Characteristic resistance under shear load

**Annex C 23**

**Vertical perforated brick HLz, form B, EN 771-1**

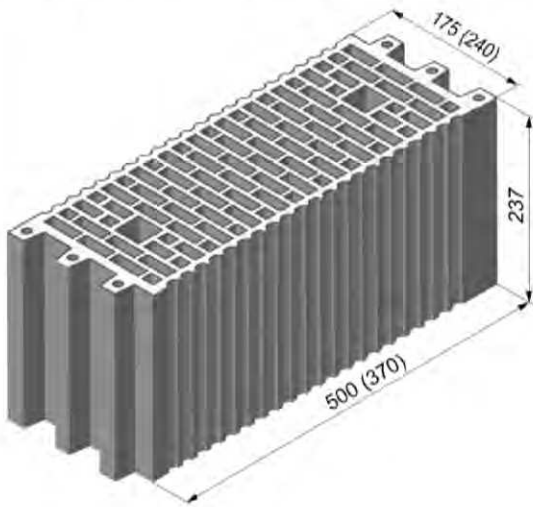

Vertical perforated brick HLz, form B, EN 771-1			
Producer	e.g. Wienerberger, Poroton		
Nominal dimensions [mm]	length L	width W	height H
	500	175	237
Density $\rho$ [kg/dm <sup>3</sup> ]	370	240	237
	$\geq 1,0$		
Compressive strength $f_b$ [N/mm <sup>2</sup> ]	4 / 6 / 8 / 10 / 12		
Standard or annex	EN 771-1		

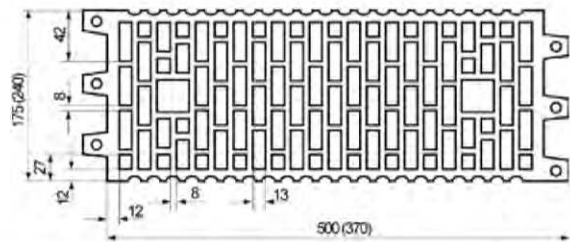

**Table C24.1:** Installation parameters

<b>Anchor rod</b>	M6	M8	M6	M8	-	M8	M10	M8	M10	-	M12	M16	M12	M16
<b>Internal threaded anchor FIS E</b>	-	-	M6	M8	11x85	-	-	-	M10	M12	15x85	-	-	-
<b>Perforated sleeve FIS H K</b>	12x50	12x85	16x85	16x130	20x85	20x130								
<b>Anchor rod and internal threaded anchor FIS E with perforated sleeve FIS H K</b>														
Max. installation torque $T_{inst,max}$ [Nm]	2													
<b>General installation parameters</b>														
Edge distance $c_{min}$	100													
Spacing	$s_{min \parallel}$	100												
	$s_{cr \parallel}$	500 (370)												
	$s_{min \perp}$	100												
	$s_{cr \perp}$	240												
<b>Drilling method</b>														
Hammer drilling with hard metal hammer drill														

**Table C24.2:** Group factors

<b>Anchor rod</b>	M6	M8	M6	M8	-	M8	M10	M8	M10	-	M12	M16	M12	M16
<b>Internal threaded anchor FIS E</b>	-	-	M6	M8	11x85	-	-	-	M10	M12	15x85	-	-	-
<b>Perforated sleeve FIS H K</b>	12x50	12x85	16x85	16x130	20x85	20x130								
Group factors $\frac{\alpha_{q,N \parallel} = \alpha_{q,V \parallel}}{\alpha_{q,N \perp} = \alpha_{q,V \perp}}$ [-]	1													

fischer injektion system FIS V masonry

**Performances**

Vertical perforated brick HLz, form B, dimensions, installation parameters

**Annex C 24**

**Vertical perforated brick HLz, form B, EN 771-1****Table C25.1:** Characteristic resistance under tensile load

Anchor rod		M6	M8	M6	M8	-	M8	M10	M8	M10	-	M12	M16	M12	M16
Internal threaded anchor FIS E		-		-		M6	M8	-		-		M10	M12	-	
				11x85						15x85					
Perforated sleeve FIS H K		12x50		12x85		16x85			16x130		20x85			20x130	
<b>Tensile load <math>N_{Rk}</math> [kN] depending on the compressive strength <math>f_b</math> (temperature range 50/80°C)</b>															
compressive strength $f_b$		use category													
4 N/mm <sup>2</sup>	w/w	w/d	0,3						0,9			1,2			
	d/d		0,4						0,9			1,2			
6 N/mm <sup>2</sup>	w/w	w/d	0,5						1,5			2,0			
	d/d		0,6						1,5			2,0			
8 N/mm <sup>2</sup>	w/w	w/d	0,75						2,0			2,5			
	d/d		0,75						2,0			2,5			
10 N/mm <sup>2</sup>	w/w	w/d	0,9						2,5			3,0			
	d/d		0,9						2,5			3,5			
12 N/mm <sup>2</sup>	w/w	w/d	0,9						3,0			3,5			
	d/d		1,2						3,0			4,0			

Factor for temperature range 72/120°C: 0,83

**Table C25.2:** Characteristic resistance under shear load

Anchor rod		M6	M8	M6	M8	-	M8	M10	M8	M10	-	M12	M16	M12	M16
Internal threaded anchor FIS E		-		-		M6	M8	-		-		M10	M12	-	
				11x85						15x85					
Perforated sleeve FIS H K		12x50		12x85		16x85			16x130		20x85			20x130	
<b>Shear load <math>V_{Rk}</math> [kN] depending on the compressive strength <math>f_b</math> (temperature range 50/80°C and 72/120°C)</b>															
compressive strength $f_b$		use category													
4 N/mm <sup>2</sup>	w/w	w/d	0,5			0,6			0,5			0,6			
	d/d														
6 N/mm <sup>2</sup>	w/w	w/d	0,75			0,9			0,75			0,9			
	d/d														
8 N/mm <sup>2</sup>	w/w	w/d	0,9			1,2			0,9			1,2			
	d/d														
10 N/mm <sup>2</sup>	w/w	w/d	1,2			1,5			1,2			1,5			
	d/d														
12 N/mm <sup>2</sup>	w/w	w/d	1,5			2,0			1,5			2,0			
	d/d														

Factor for job site tests and displacements see annex C110

fischer injektion system FIS V masonry

**Performances**Vertical perforated brick HLz, form B,  
Characteristic resistance under tensile and shear load**Annex C 25**



**Vertical perforated brick HLz, 2DF, EN 771-1**

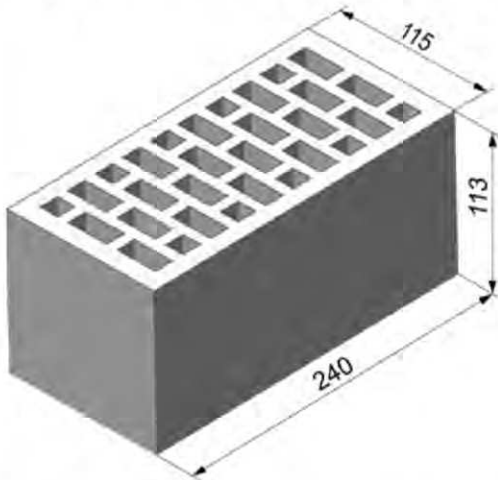

Vertical perforated brick HLz, 2DF, EN 771-1			
Producer	e.g. Wienerberger		
Nominal dimensions [mm]	length L	width W	height H
	240	115	113
Density $\rho$ [kg/dm <sup>3</sup> ]	≥ 1,4		
Compressive strength $f_b$ [N/mm <sup>2</sup> ]	6 / 10 / 16 / 20 / 28		
Standard or annex	EN 771-1		

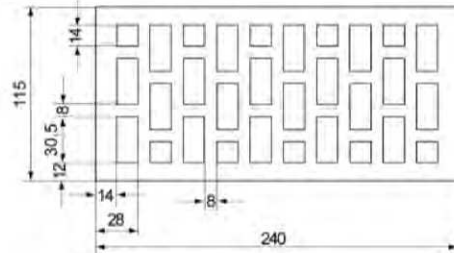

**Table C26.1:** Installation parameters

<b>Anchor rod</b>	M6	M8	M6	M8	-	M8	M10	-	M12	M16
<b>Internal threaded anchor FIS E</b>	-		-		M6	M8	-		M10	M12
	-		-		11x85		-		15x85	
<b>Perforated sleeve FIS H K</b>	12x50		12x85		16x85			20x85		
<b>Anchor rod and internal threaded anchor FIS E with perforated sleeve FIS H K</b>										
Max. installation torque $T_{inst,max}$ [Nm]	2									
<b>General installation parameters</b>										
Edge distance $c_{min}$	80									
Spacing $s_{cr \parallel} = s_{min \parallel}$ [mm]	240									
	$s_{cr \perp} = s_{min \perp}$	115								
<b>Drilling method</b>										
Hammer drilling with hard metal hammer drill										

**Table C26.2:** Group factors

<b>Anchor rod</b>	M6	M8	M6	M8	-	M8	M10	-	M12	M16
<b>Internal threaded anchor FIS E</b>	-		-		M6	M8	-		M10	M12
	-		-		11x85		-		15x85	
<b>Perforated sleeve FIS H K</b>	12x50		12x85		16x85			20x85		
Group factors $\alpha_{q,N \parallel}$ [-]	$\alpha_{q,N \parallel}$	2								
	$\alpha_{q,V \parallel}$	2								
	$\alpha_{q,N \perp}$	2								
	$\alpha_{q,V \perp}$	2								

fischer injektion system FIS V masonry

**Performances**

Vertical perforated brick HLz, 2DF, dimensions, installation parameters

**Annex C 26**

<b>Vertical perforated brick HLz, 2DF, EN 771-1</b>													
<b>Table C27.1: Characteristic resistance under tensile load</b>													
Anchor rod		M6	M8	M6	M8	-		M8	M10	-		M12	M16
Internal threaded anchor FIS E		-		-		M6	M8	-		M10	M12	-	
						11x85				15x85			
Perforated sleeve FIS H K		12x50		12x85		16x85				20x85			
<b>Tensile load <math>N_{Rk}</math> [kN] depending on the compressive strength <math>f_b</math> (temperature range 50/80°C)</b>													
compressive strength $f_b$		use category											
6 N/mm <sup>2</sup>	w/w	w/d	0,75	0,9	0,75				0,9				
	d/d		0,75	1,2	0,75				0,9				
10 N/mm <sup>2</sup>	w/w	w/d	1,2	1,5	1,2				1,5				
	d/d		1,2	2,0	1,2				1,5				
16 N/mm <sup>2</sup>	w/w	w/d	2,0	2,5	2,0				2,0				
	d/d		2,0	3,0	2,0				2,5				
20 N/mm <sup>2</sup>	w/w	w/d	2,5	3,5	2,5				3,0				
	d/d		2,5	4,0	2,5				3,0				
28 N/mm <sup>2</sup>	w/w	w/d	3,0	5,0	3,5				4,0				
	d/d		3,5	5,5	3,5				4,5				
Factor for temperature range 72/120°C: 0,83													
<b>Table C27.2: Characteristic resistance under shear load</b>													
Anchor rod		M6	M8	M6	M8	-		M8	M10	-		M12	M16
Internal threaded anchor FIS E		-		-		M6	M8	-		M10	M12	-	
						11x85				15x85			
Perforated sleeve FIS H K		12x50		12x85		16x85				20x85			
<b>Shear load <math>V_{Rk}</math> [kN] depending on the compressive strength <math>f_b</math> (temperature range 50/80°C and 72/120°C)</b>													
compressive strength $f_b$		use category											
6 N/mm <sup>2</sup>	w/w	w/d	1,2	1,5	1,2	2,0	1,2	1,5		2,5			
	d/d		1,2	1,5	1,2	2,0	1,2	1,5		2,5			
10 N/mm <sup>2</sup>	w/w	w/d	2,0	2,5	2,0	4,0	2,0	2,5		4,5			
	d/d		2,0	2,5	2,0	4,0	2,0	2,5		4,5			
16 N/mm <sup>2</sup>	w/w	w/d	3,0	3,5	3,0	6,0	3,0	3,5		7,0			
	d/d		3,0	3,5	3,0	6,0	3,0	3,5		7,0			
20 N/mm <sup>2</sup>	w/w	w/d	4,0	4,5	4,0	7,5	4,0	4,5		8,5			
	d/d		4,0	4,5	4,0	7,5	4,0	4,5		8,5			
28 N/mm <sup>2</sup>	w/w	w/d	5,0	6,5	5,0	9,5	5,0	6,5		12,0			
	d/d		5,0	6,5	5,0	9,5	5,0	6,5		12,0			
Factor for job site tests and displacements see annex C110													
fischer injektion system FIS V masonry										<b>Annex C 27</b>			
<b>Performances</b> Vertical perforated brick HLz, 2DF, Characteristic resistance under tensile and shear load													

**Vertical perforated brick HLz, U8, EN 771-1**

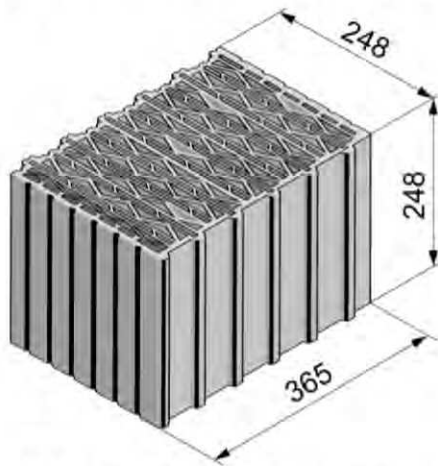

Vertical perforated brick HLz, U8, EN 771-1			
Producer	-		
Nominal dimensions [mm]	length L	width W	height H
	248	365	248
Density $\rho$ [kg/dm <sup>3</sup> ]	0,6		
Compressive strength $f_b$ [N/mm <sup>2</sup> ]	4 / 6 / 8		
Standard or annex	EN 771-1		

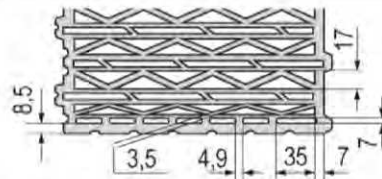

**Table C28.1:** Installation parameters  
(Pre-positioned anchorage with perforated sleeve FIS HK)

Anchor rod	M6	M8	M6	M8	-	M8	M10	M8	M10	-	M12	M16	M12	M16	M12	M16	
Internal threaded anchor FIS E	-	-	-	-	M6	M8	-	-	M10	M12	-	-	-	-	-	-	
					11x85				15x85								
Perforated sleeve FIS H K	12x50		12x85		16x85			16x130		20x85			20x130		20x200		
<b>Anchor rod and internal threaded anchor FIS E with perforated sleeve FIS H K</b>																	
Max. installation torque $T_{inst,max}$ [Nm]	3	5	3	5	3	5	5										
<b>General installation parameters</b>																	
Edge distance $c_{min}$							60										
Spacing	$s_{min} \parallel$							80									
	$s_{cr} \parallel$							250									
	$s_{min} \perp$							80									
	$s_{cr} \perp$							250									
	<b>Drilling method</b>																
Rotary drilling with carbide drill																	

**Table C28.2:** Group factors

Anchor rod	M6	M8	M6	M8	-	M8	M10	M8	M10	-	M12	M16	M12	M16	M12	M16
Internal threaded anchor FIS E	-	-	-	-	M6	M8	-	-	M10	M12	-	-	-	-	-	-
					11x85				15x85							
Perforated sleeve FIS H K	12x50		12x85		16x85			16x130		20x85			20x130		20x200	
Group factors	$\alpha_{a,N} \parallel$							1,3								
	$\alpha_{a,V} \parallel$							1,2								
	$\alpha_{a,N} \perp$							1,3								
	$\alpha_{a,V} \perp$							1,0								

fischer injektion system FIS V masonry

**Performances**  
Vertical perforated brick HLz, U8, dimensions, installation parameters

**Annex C 28**

**Vertical perforated brick HLz, U8, EN 771-1****Table C29.1:** Installation parameters  
(Push through anchorage with perforated sleeve FIS HK)

Anchor rod		M10	M12	M16
Perforated sleeve FIS H K		18x130/200		22x130/200
<b>Anchor rod with perforated sleeve FIS H K</b>				
Max. installation torque	$T_{inst,max}$ [Nm]	5		
<b>General installation parameters</b>				
Edge distance	$c_{min}$	60		
Spacing	$s_{min} \parallel$	80		
	$s_{cr} \parallel$	250		
	$s_{min} \perp$	80		
	$s_{cr} \perp$	250		
<b>Drilling method</b>				
Rotary drilling with carbide drill				

**Table C29.2:** Group factors

Anchor rod		M10	M12	M16
Perforated sleeve FIS H K		18x130/200		22x130/200
Group factors	$\alpha_{q,N} \parallel$	1,3		
	$\alpha_{q,V} \parallel$	1,2		
	$\alpha_{q,N} \perp$	1,3		
	$\alpha_{q,V} \perp$	1,0		

fischer injektion system FIS V masonry

**Performances**  
Vertical perforated brick HLz, U8, dimensions, installation parameters**Annex C 29**

**Vertical perforated brick HLz, U8, EN 771-1****Table C30.1:** Characteristic resistance under tensile load (Pre-positioned anchorage)

Anchor rod	M6	M8	M6	M8	-	M8	M10	M8	M10	-	M12	M16	M12	M16	M12	M16
Internal threaded anchor FIS E	-	-	-	-	M6	M8	-	-	-	M10	M12	-	-	-	-	-
					11x85					15x85						
Perforated sleeve FIS H K	12x50		12x85		16x85			16x130		20x85			20x130		20x200	

**Tensile load  $N_{Rk}$  [kN] depending on the compressive strength  $f_b$  (temperature range 50/80°C)**

compressive strength $f_b$	use category															
	4 N/mm <sup>2</sup>	w/w	w/d	1,2				1,2								
d/d		1,2				1,5										
6 N/mm <sup>2</sup>	w/w	w/d	1,5				1,5									
	d/d		1,5				1,5									
8 N/mm <sup>2</sup>	w/w	w/d	1,5				2,0									
	d/d		2,0				2,0									

**Table C30.2:** Characteristic resistance under tensile load (Push through anchorage)

Anchor rod	M10		M12		M16	
Perforated sleeve FIS H K	18x130/200				22x130/200	

**Tensile load  $N_{Rk}$  [kN] depending on the compressive strength  $f_b$  (temperature range 50/80°C)**

compressive strength $f_b$	use category															
	4 N/mm <sup>2</sup>	w/w	w/d	1,2												
d/d		1,5														
6 N/mm <sup>2</sup>	w/w	w/d	1,5													
	d/d		1,5													
8 N/mm <sup>2</sup>	w/w	w/d	2,0													
	d/d		2,0													

Factor for job site tests and displacements see annex C110.

Factor for temperature range 72/120°C: 0,83

fischer injektion system FIS V masonry

**Performances**

Vertical perforated brick HLz, U8, Characteristic resistance under tensile load

**Annex C 30**

**Vertical perforated brick HLz, U8, EN 771-1****Table C31.1:** Characteristic resistance under shear load (Pre-positioned anchorage)

<b>Anchor rod</b>	<b>M6</b>	<b>M8</b>	<b>M6</b>	<b>M8</b>	-	<b>M8</b>	<b>M10</b>	<b>M8</b>	<b>M10</b>	-	<b>M12</b>	<b>M16</b>	<b>M12</b>	<b>M16</b>	<b>M12</b>	<b>M16</b>
<b>Internal threaded anchor FIS E</b>	-	-	<b>M6</b>	<b>M8</b>	<b>11x85</b>	-	-	<b>M10</b>	<b>M12</b>	<b>15x85</b>	-	-	-	-	-	-
<b>Perforated sleeve FIS H K</b>	<b>12x50</b>	<b>12x85</b>	<b>16x85</b>		<b>16x130</b>		<b>20x85</b>		<b>20x130</b>		<b>20x200</b>					

**Shear load  $V_{RK}$  [kN] depending on the compressive strength  $f_b$  (temperature range 50/80°C and 72/120°C)**

compressive strength $f_b$	use category		
<b>4 N/mm<sup>2</sup></b>	w/w	w/d	1,2
	d/d		
<b>6 N/mm<sup>2</sup></b>	w/w	w/d	1,5
	d/d		
<b>8 N/mm<sup>2</sup></b>	w/w	w/d	1,5
	d/d		

**Table C31.2:** Characteristic resistance under shear load (Push through anchorage)

<b>Anchor rod</b>	<b>M10</b>	<b>M12</b>	<b>M16</b>
<b>Perforated sleeve FIS H K</b>	<b>18x130/200</b>		<b>22x130/200</b>

**Shear load  $V_{RK}$  [kN] depending on the compressive strength  $f_b$  (temperature range 50/80°C and 72/120°C)**

compressive strength $f_b$	use category		
<b>4 N/mm<sup>2</sup></b>	w/w	w/d	1,2
	d/d		
<b>6 N/mm<sup>2</sup></b>	w/w	w/d	1,5
	d/d		
<b>8 N/mm<sup>2</sup></b>	w/w	w/d	1,5
	d/d		

Factor for job site tests and displacements see annex C108.

fischer injektion system FIS V masonry

**Performances**

Vertical perforated brick HLz, U8, Characteristic resistance under shear load

**Annex C 31**

**Vertical perforated brick HLz, T10, T11, EN 771-1**

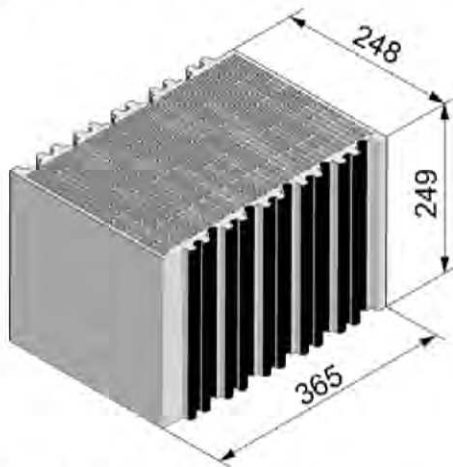

Vertical perforated brick HLz, T10, T11, EN 771-1			
Producer	-		
Nominal dimensions [mm]	length L	width W	height H
	248	365	249
Density $\rho$ [kg/dm <sup>3</sup> ]	0,7		
Compressive strength $f_b$ [N/mm <sup>2</sup> ]	8 / 10 / 12		
Standard or annex	EN 771-1		

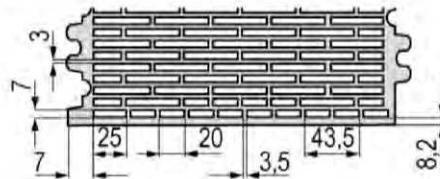

**Table C32.1:** Installation parameters  
(Pre-positioned anchorage with perforated sleeve FIS HK)

Anchor rod	M6	M8	M6	M8	-	M8	M10	M8	M10	-	M12	M16	M12	M16	M12	M16
Internal threaded anchor FIS E	-	-	-	-	M6	M8	-	-	M10	M12	-	-	-	-	-	-
Perforated sleeve FIS H K	12x50		12x85		16x85			16x130		20x85		20x130		20x200		
<b>Anchor rod and internal threaded anchor FIS E with perforated sleeve FIS H K</b>																
Max. installation torque $T_{inst,max}$ [Nm]	3				5		3		5							
<b>General installation parameters</b>																
Edge distance $c_{min}$	60															
Spacing	$s_{min} \parallel$	80														
	$s_{cr} \parallel$	250														
	$s_{min} \perp$	80														
	$s_{cr} \perp$	250														
<b>Drilling method</b>																
Rotary drilling with carbide drill																

**Table C32.2:** Group factors

Anchor rod	M6	M8	M6	M8	-	M8	M10	M8	M10	-	M12	M16	M12	M16	M12	M16
Internal threaded anchor FIS E	-	-	-	-	M6	M8	-	-	M10	M12	-	-	-	-	-	-
Perforated sleeve FIS H K	12x50		12x85		16x85			16x130		20x85		20x130		20x200		
Group factors	$\alpha_{q,N} \parallel$	1,7														
	$\alpha_{q,V} \parallel$	0,5														
	$\alpha_{q,N} \perp$	1,3														
	$\alpha_{q,V} \perp$	0,5														

fischer injektion system FIS V masonry

**Performances**  
Vertical perforated brick HLz, T10, T11, dimensions, installation parameters

**Annex C 32**

**Vertical perforated brick HLz, T10, T11, EN 771-1****Table C33.1:** Installation parameters  
(Push through anchorage with perforated sleeve FIS HK)

Anchor rod		M10	M12	M16
Perforated sleeve FIS H K		18x130/200		22x130/200
<b>Anchor rod with perforated sleeve FIS H K</b>				
Max. installation torque	$T_{inst,max}$ [Nm]	5		
<b>General installation parameters</b>				
Edge distance	$c_{min}$	60		
Spacing	$s_{min} \parallel$	80		
	$s_{cr} \parallel$	250		
	$s_{min} \perp$	80		
	$s_{cr} \perp$	250		
<b>Drilling method</b>				
Rotary drilling with carbide drill				

**Table C33.2:** Group factors

Anchor rod		M10	M12	M16
Perforated sleeve FIS H K		18x130/200		22x130/200
Group factors	$\alpha_{q,N} \parallel$	1,7		
	$\alpha_{q,V} \parallel$	0,5		
	$\alpha_{q,N} \perp$	1,3		
	$\alpha_{q,V} \perp$	0,5		

fischer injektion system FIS V masonry

**Performances**  
Vertical perforated brick HLz, T10, T11, dimensions, installation parameters**Annex C 33**



**Vertical perforated brick HLz, T10, T11, EN 771-1****Table C34.1:** Characteristic resistance under tensile load (Pre-positioned anchorage)

Anchor rod	M6	M8	M6	M8	-	M8	M10	M8	M10	-	M12	M16	M12	M16	M12	M16
Internal threaded anchor FIS E	-	-	-	-	M6	M8	-	-	-	M10	M12	-	-	-	-	-
					11x85					15x85						
Perforated sleeve FIS H K	12x50		12x85		16x85			16x130		20x85			20x130		20x200	

**Tensile load  $N_{Rk}$  [kN] depending on the compressive strength  $f_b$  (temperature range 50/80°C)**

compressive strength $f_b$	use category															
	8 N/mm <sup>2</sup>	w/w	w/d	1,5				1,5								
d/d		1,5				2,0										
10 N/mm <sup>2</sup>	w/w	w/d	1,5				2,0									
	d/d		2,0				2,0									
12 N/mm <sup>2</sup>	w/w	w/d	2,0				2,0									
	d/d		2,0				2,5									

**Table C34.2:** Characteristic resistance under tensile load (Push through anchorage)

Anchor rod	M10				M12				M16			
Perforated sleeve FIS H K	18x130/200								22x130/200			

**Tensile load  $N_{Rk}$  [kN] depending on the compressive strength  $f_b$  (temperature range 50/80°C)**

compressive strength $f_b$	use category																	
	8 N/mm <sup>2</sup>	w/w	w/d	1,5								1,5						
d/d		2,0								2,0								
10 N/mm <sup>2</sup>	w/w	w/d	2,0								2,0							
	d/d		2,0								2,0							
12 N/mm <sup>2</sup>	w/w	w/d	2,0								2,0							
	d/d		2,5								2,5							

Factor for job site tests and displacements see annex C110.

Factor for temperature range 72/120°C: 0,83

fischer injektion system FIS V masonry

**Performances**

Vertical perforated brick HLz, T10, T11, Characteristic resistance under tensile load

**Annex C 34**

**Vertical perforated brick HLz, T10, T11, EN 771-1****Table C35.1:** Characteristic resistance under shear load (Pre-positioned anchorage)

<b>Anchor rod</b>	<b>M6</b>	<b>M8</b>	<b>M6</b>	<b>M8</b>	-	<b>M8</b>	<b>M10</b>	<b>M8</b>	<b>M10</b>	-	<b>M12</b>	<b>M16</b>	<b>M12</b>	<b>M16</b>	<b>M12</b>	<b>M16</b>
<b>Internal threaded anchor FIS E</b>	-	-	-	-	<b>M6</b>	<b>M8</b>	-	-	<b>M10</b>	<b>M12</b>	-	-	-	-	-	-
					<b>11x85</b>				<b>15x85</b>							
<b>Perforated sleeve FIS H K</b>	<b>12x50</b>		<b>12x85</b>		<b>16x85</b>			<b>16x130</b>		<b>20x85</b>			<b>20x130</b>		<b>20x200</b>	

**Shear load  $V_{RK}$  [kN] depending on the compressive strength  $f_b$  (temperature range 50/80°C and 72/120°C)**

compressive strength $f_b$	use category							
	<b>8 N/mm<sup>2</sup></b>	w/w	w/d	0,9		1,5		2,0
	d/d							
<b>10 N/mm<sup>2</sup></b>	w/w	w/d	0,9		1,5		2,0	
	d/d							
<b>12 N/mm<sup>2</sup></b>	w/w	w/d	1,2		2,0		2,0	
	d/d							

**Table C35.2:** Characteristic resistance under shear load (Push through anchorage)

<b>Anchor rod</b>	<b>M10</b>	<b>M12</b>	<b>M16</b>
<b>Perforated sleeve FIS H K</b>	<b>18x130/200</b>		<b>22x130/200</b>

**Shear load  $V_{RK}$  [kN] depending on the compressive strength  $f_b$  (temperature range 50/80°C and 72/120°C)**

compressive strength $f_b$	use category					
	<b>8 N/mm<sup>2</sup></b>	w/w	w/d	1,5		2,0
	d/d					
<b>10 N/mm<sup>2</sup></b>	w/w	w/d	1,5		2,0	
	d/d					
<b>12 N/mm<sup>2</sup></b>	w/w	w/d	2,0		2,0	
	d/d					

Factor for job site tests and displacements see annex C110.

fischer injektion system FIS V masonry

**Performances**

Vertical perforated brick HLz, T10, T11, Characteristic resistance under shear load

**Annex C 35**

**Vertical perforated brick HLz, T7 PF, filled with perlite, EN 771-1**

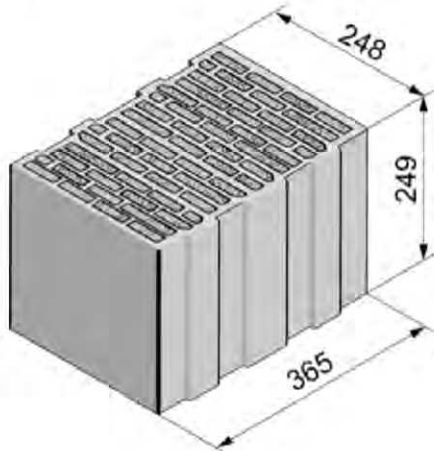

Vertical perforated brick HLz, T7 PF, filled with perlite, EN 771-1			
Producer	-		
Nominal dimensions [mm]	length L	width W	height H
	248	365	249
Density $\rho$ [kg/dm <sup>3</sup> ]	0,5		
Compressive strength $f_b$ [N/mm <sup>2</sup> ]	4 / 6		
Standard or annex	EN 771-1		

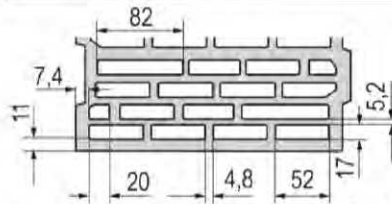

**Table C36.1:** Installation parameters  
(Pre-positioned anchorage with perforated sleeve FIS HK)

Anchor rod	M6	M8	M6	M8	-	M8	M10	M8	M10	-	M12	M16	M12	M16	M12	M16
Internal threaded anchor FIS E	-	-	-	-	M6	M8	-	-	M10	M12	-	-	-	-	-	-
					11x85				15x85							
Perforated sleeve FIS H K	12x50		12x85		16x85			16x130		20x85			20x130		20x200	
<b>Ankerstangen und Innengewindeanker FIS E mit Injektionsanker-Hülse FIS H K</b>																
Max. installation torque $T_{inst,max}$ [Nm]	2					5		2		5						
<b>General installation parameters</b>																
Edge distance $c_{min}$								60								
Spacing		$s_{min}$	$s_{cr}$	$s_{min}$ ⊥	$s_{cr}$ ⊥	[mm]			80							
									250							
									80							
									250							
<b>Drilling method</b>																
Rotary drilling with carbide drill																

**Table C36.2:** Group factors

Anchor rod	M6	M8	M6	M8	-	M8	M10	M8	M10	-	M12	M16	M12	M16	M12	M16
Internal threaded anchor FIS E	-	-	-	-	M6	M8	-	-	M10	M12	-	-	-	-	-	-
					11x85				15x85							
Perforated sleeve FIS H K	12x50		12x85		16x85			16x130		20x85			20x130		20x200	
Group factors		$\alpha_{q,N}$	$\alpha_{q,V}$	$\alpha_{q,N}$ ⊥	$\alpha_{q,V}$ ⊥	[-]			1,1							
									1,2							
									1,1							
									1,2							

fischer injektion system FIS V masonry

**Performances**  
Vertical perforated brick HLz, T7 PF, filled with perlite, dimensions, installation parameters

**Annex C 36**

**Vertical perforated brick HLz, T7 PF, filled with perlite, EN 771-1****Table C37.1:** Installation parameters  
(Push through anchorage with perforated sleeve FIS HK)

Anchor rod		M10	M12	M16
Perforated sleeve FIS H K		18x130/200		22x130/200
<b>Anchor rod with perforated sleeve FIS H K</b>				
Max. installation torque	$T_{inst,max}$ [Nm]	5		
<b>General installation parameters</b>				
Edge distance	$c_{min}$	60		
Spacing	$s_{min \parallel}$	80		
	$s_{cr \parallel}$	250		
	$s_{min \perp}$	80		
	$s_{cr \perp}$	250		
<b>Drilling method</b>				
Rotary drilling with carbide drill				

**Table C37.2:** Group factors

Anchor rod		M10	M12	M16
Perforated sleeve FIS H K		18x130/200		22x130/200
Group factors	$\alpha_{a,N \parallel}$	1,1		
	$\alpha_{a,V \parallel}$	1,2		
	$\alpha_{a,N \perp}$	1,1		
	$\alpha_{a,V \perp}$	1,2		

fischer injektion system FIS V masonry

**Performances**Vertical perforated brick HLz, T7 PF, filled with perlite,  
dimensions, installation parameters**Annex C 37**

**Vertical perforated brick HLz, T7 PF, filled with perlite, EN 771-1****Table C38.1:** Characteristic resistance under tensile load (Pre-positioned anchorage)

Anchor rod	M6	M8	M6	M8	-	M8	M10	M8	M10	-	M12	M16	M12	M16	M12	M16
Internal threaded anchor FIS E	-		-		M6	M8	-		-		M10	M12	-		-	
					11x85						15x85					
Perforated sleeve FIS H K	12x50		12x85		16x85			16x130		20x85			20x130		20x200	

**Tensile load  $N_{Rk}$  [kN] depending on the compressive strength  $f_b$  (temperature range 50/80°C)**

compressive strength $f_b$	use category																										
4 N/mm <sup>2</sup>	w/w	w/d	1,2					1,2					1,2					1,2					2,0				
	d/d		1,5					1,5					1,5					1,5					2,0				
6 N/mm <sup>2</sup>	w/w	w/d	1,5					1,5					1,5					1,5					2,5				
	d/d		1,5					2,0					1,5					2,0					3,0				

**Table C38.2:** Characteristic resistance under tensile load (Push through anchorage)

Anchor rod	M10				M12				M16							
Perforated sleeve FIS H K	18x130/200								22x130/200							

**Tensile load  $N_{Rk}$  [kN] depending on the compressive strength  $f_b$  (temperature range 50/80°C)**

compressive strength $f_b$	use category																	
4 N/mm <sup>2</sup>	w/w	w/d	1,2								1,2							
	d/d		1,5								1,5							
6 N/mm <sup>2</sup>	w/w	w/d	1,5								1,5							
	d/d		2,0								2,0							

Factor for job site tests and displacements see annex C110

Factor for temperature range 72/120°C: 0,83

fischer injektion system FIS V masonry

**Performances**

Vertical perforated brick HLz, T7 PF, filled with perlite,  
Characteristic resistance under tensile load

**Annex C 38**

**Vertical perforated brick HLz, T7 PF, filled with perlite, EN 771-1****Table C39.1:** Characteristic resistance under shear load (Pre-positioned anchorage)

Anchor rod	M6	M8	M6	M8	-	M8	M10	M8	M10	-	M12	M16	M12	M16	M12	M16
Internal threaded anchor FIS E	-		-		M6	M8	-		-		M10	M12	-		-	
					11x85						15x85					
Perforated sleeve FIS H K	12x50		12x85		16x85			16x130		20x85			20x130		20x200	

**Shear load  $V_{RK}$  [kN] depending on the compressive strength  $f_b$  (temperature range 50/80°C and 72/120°C)**

compressive strength $f_b$	use category														
4 N/mm <sup>2</sup>	w/w	w/d	0,9	1,5								1,2			
	d/d														
6 N/mm <sup>2</sup>	w/w	w/d	1,2	2,0								1,5			
	d/d														

**Table C39.2:** Characteristic resistance under shear load (Push through anchorage)

Anchor rod	M10				M12				M16			
Perforated sleeve FIS H K	18x130/200								22x130/200			

**Shear load  $V_{RK}$  [kN] depending on the compressive strength  $f_b$  (temperature range 50/80°C and 72/120°C)**

compressive strength $f_b$	use category													
4 N/mm <sup>2</sup>	w/w	w/d	1,5								1,2			
	d/d													
6 N/mm <sup>2</sup>	w/w	w/d	2,0								1,5			
	d/d													

Factor for job site tests and displacements see annex C110

fischer injektion system FIS V masonry

**Performances**Vertical perforated brick HLz, T7 PF, filled with perlite,  
Characteristic resistance under shear load**Annex C 39**

**Vertical perforated brick HLz, T9 MW, filled with mineral wool, EN 771-1**

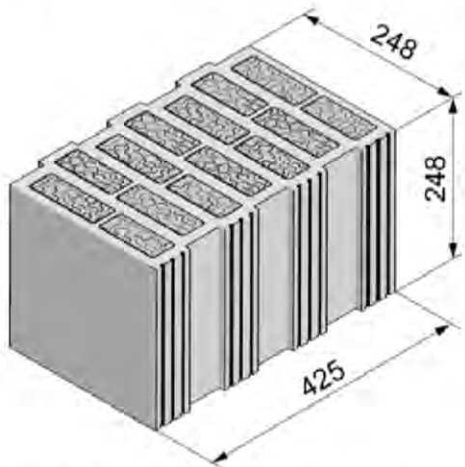

Vertical perforated brick HLz, T9 MW, filled with mineral wool, EN 771-1			
Producer	-		
Nominal dimensions [mm]	length L	width W	height H
	248	425	248
Density $\rho$ [kg/dm <sup>3</sup> ]	0,8		
Compressive strength $f_b$ [N/mm <sup>2</sup> ]	4 / 6 / 8		
Standard or annex	EN 771-1		

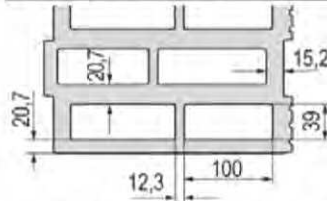

**Table C40.1:** Installation parameters  
(Pre-positioned anchorage with perforated sleeve FIS HK)

<b>Anchor rod</b>	M6	M8	M6	M8	-	M8	M10	M8	M10	-	M12	M16	M12	M16	M12	M16
<b>Internal threaded anchor FIS E</b>	-	-	-	-	M6	M8	-	-	-	M10	M12	-	-	-	-	-
					11x85					15x85						
<b>Perforated sleeve FIS H K</b>	12x50		12x85		16x85			16x130		20x85			20x130		20x200	
<b>Anchor rod and internal threaded anchor FIS E with perforated sleeve FIS H K</b>																
Max. installation torque	$T_{inst,max}$ [Nm]	3				5		3		5						
<b>General installation parameters</b>																
Edge distance	$c_{min}$							60								
Spacing	$s_{min} \parallel$							80								
	$s_{cr} \parallel$							250								
	$s_{min} \perp$							80								
	$s_{cr} \perp$							250								
<b>Drilling method</b>																
Rotary drilling with carbide drill																

**Table C40.2:** Group factors

<b>Anchor rod</b>	M6	M8	M6	M8	-	M8	M10	M8	M10	-	M12	M16	M12	M16	M12	M16
<b>Internal threaded anchor FIS E</b>	-	-	-	-	M6	M8	-	-	-	M10	M12	-	-	-	-	-
					11x85					15x85						
<b>Perforated sleeve FIS H K</b>	12x50		12x85		16x85			16x130		20x85			20x130		20x200	
Group factors	$\alpha_{q,N} \parallel$							1,3								
	$\alpha_{q,V} \parallel$							1,2								
	$\alpha_{q,N} \perp$							0,6								
	$\alpha_{q,V} \perp$							1,2								

fischer injektion system FIS V masonry

**Performances**

Vertical perforated brick HLz, T9 MW, filled with mineral wool, dimensions, installation parameters

**Annex C 40**

**Vertical perforated brick HLz, T9 MW, filled with mineral wool, EN 771-1****Table C41.1:** Installation parameters  
(Push through anchorage with perforated sleeve FIS HK)

Anchor rod		M10	M12	M16
Perforated sleeve FIS H K		18x130/200		22x130/200
<b>Anchor rod with perforated sleeve FIS H K</b>				
Max. installation torque	$T_{inst,max}$ [Nm]	5		
<b>General installation parameters</b>				
Edge distance	$c_{min}$	60		
	$s_{min} \parallel$	80		
Spacing	$s_{cr} \parallel$	250		
	$s_{min} \perp$	80		
	$s_{cr} \perp$	250		
<b>Drilling method</b>				
Rotary drilling with carbide drill				

**Table C41.2:** Group factors

Anchor rod		M10	M12	M16
Perforated sleeve FIS H K		18x130/200		22x130/200
Group factors	$\alpha_{q,N} \parallel$	1,3		
	$\alpha_{q,V} \parallel$	1,2		
	$\alpha_{q,N} \perp$	0,6		
	$\alpha_{q,V} \perp$	1,2		

fischer injektion system FIS V masonry

**Performances**Vertical perforated brick HLz, T9 MW, filled with mineral wool,  
dimensions, installation parameters**Annex C 41**



**Vertical perforated brick HLz, T9 MW, filled with mineral wool, EN 771-1****Table C42.1:** Characteristic resistance under tensile load (Pre-positioned anchorage)

Anchor rod	M6	M8	M6	M8	-	M8	M10	M8	M10	-	M12	M16	M12	M16	M12	M16
Internal threaded anchor FIS E	-	-	-	-	M6	M8	-	-	M10	M12	-	-	-	-	-	-
Perforated sleeve FIS H K	12x50		12x85		16x85			16x130		20x85			20x130		20x200	
<b>Tensile load <math>N_{Rk}</math> [kN] depending on the compressive strength <math>f_b</math> (temperature range 50/80°C)</b>																
compressive strength $f_b$	use category															
4 N/mm <sup>2</sup>	w/w	w/d	1,5		2,0			3,0		2,5			4,0			
	d/d		2,0		2,5			3,0		2,5			4,5			
6 N/mm <sup>2</sup>	w/w	w/d	2,0		2,5			3,5		3,0			5,0			
	d/d		2,0		3,0			4,0		3,0			5,5			
8 N/mm <sup>2</sup>	w/w	w/d	2,5		3,0			4,0		3,5			6,0			
	d/d		2,5		3,0			4,5		3,5			6,5			

**Table C42.2:** Characteristic resistance under tensile load (Push through anchorage)

Anchor rod	M10		M12		M16	
Perforated sleeve FIS H K	18x130/200				22x130/200	
<b>Tensile load <math>N_{Rk}</math> [kN] depending on the compressive strength <math>f_b</math> (temperature range 50/80°C)</b>						
compressive strength $f_b$	use category					
4 N/mm <sup>2</sup>	w/w	w/d	3,0		4,0	
	d/d		3,0		4,5	
6 N/mm <sup>2</sup>	w/w	w/d	3,5		5,0	
	d/d		4,0		5,5	
8 N/mm <sup>2</sup>	w/w	w/d	4,0		6,0	
	d/d		4,5		6,5	

Factor for job site tests and displacements see annex C110

Factor for temperature range 72/120°C: 0,83

fischer injektion system FIS V masonry

**Performances**Vertical perforated brick HLz, T9 MW, filled with mineral wool;  
Characteristic resistance under tensile load**Annex C 42**

<b>Vertical perforated brick HLz, T9 MW, filled with mineral wool, EN 771-1</b>																			
<b>Table C43.1: Characteristic resistance under shear load (Pre-positioned anchorage)</b>																			
Anchor rod		M6	M8	M6	M8	-		M8	M10	M8	M10	-		M12	M16	M12	M16	M12	M16
Internal threaded anchor FIS E		-		-		M6	M8	-		-		M10	M12	-				-	
Perforated sleeve FIS H K		12x50		12x85		16x85			16x130			20x85			20x130		20x200		
<b>Shear load <math>V_{RK}</math> [kN] depending on the compressive strength <math>f_b</math> (temperature range 50/80°C and 72/120°C)</b>																			
compressive strength $f_b$		use category																	
4 N/mm <sup>2</sup>	w/w	w/d	2,0	2,0			2,5			2,0			1,5						
	d/d			2,0			2,5			2,0			1,5						
6 N/mm <sup>2</sup>	w/w	w/d	2,5	2,5			3,0			2,5			2,0						
	d/d			2,5			3,0			2,5			2,0						
8 N/mm <sup>2</sup>	w/w	w/d	2,5	3,0			4,0			3,0			2,5						
	d/d			3,0			4,0			3,0			2,5						
<b>Table C43.2: Characteristic resistance under shear load (Push through anchorage)</b>																			
Anchor rod		M10				M12				M16									
Perforated sleeve FIS H K		18x130/200								22x130/200									
<b>Shear load <math>V_{RK}</math> [kN] depending on the compressive strength <math>f_b</math> (temperature range 50/80°C and 72/120°C)</b>																			
compressive strength $f_b$		use category																	
4 N/mm <sup>2</sup>	w/w	w/d	2,5								2,0								
	d/d		2,5								2,0								
6 N/mm <sup>2</sup>	w/w	w/d	3,0								2,5								
	d/d		3,0								2,5								
8 N/mm <sup>2</sup>	w/w	w/d	4,0								3,0								
	d/d		4,0								3,0								
Factor for job site tests and displacements see annex C110.																			
fischer injektion system FIS V masonry														<b>Annex C 43</b>					
<b>Performances</b> Vertical perforated brick HLz, T9 MW, filled with mineral wool; Characteristic resistance under shear load																			

**Vertical perforated brick HLz, FZ 7, filled with mineral wool, EN 771-1**

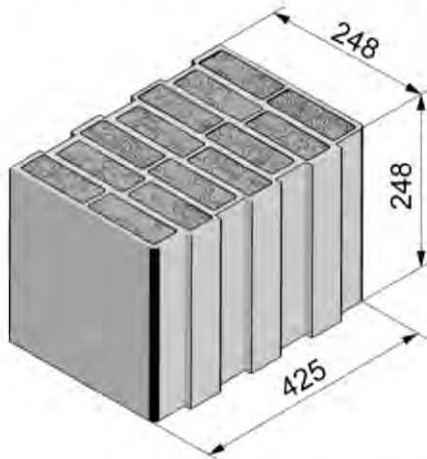

Vertical perforated brick HLz, FZ 7, filled with mineral wool, EN 771-1			
Producer	-		
Nominal dimensions [mm]	length L	width W	height H
	248	425	248
Density $\rho$ [kg/dm <sup>3</sup> ]	0,6		
Compressive strength $f_b$ [N/mm <sup>2</sup> ]	4 / 6 / 8		
Standard or annex	EN 771-1		

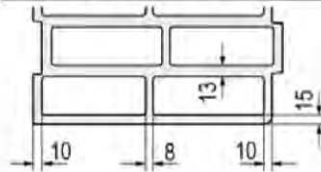

**Table C44.1:** Installation parameters  
(Pre-positioned anchorage with perforated sleeve FIS HK)

<b>Anchor rod</b>	M6	M8	M6	M8	-	M8	M10	M8	M10	-	M12	M16	M12	M16	M12	M16	
<b>Internal threaded anchor FIS E</b>	-	-	M6	M8		-	-	M10	M12		-			-			
			11x85					15x85									
<b>Perforated sleeve FIS H K</b>	12x50		12x85		16x85			16x130		20x85			20x130		20x200		
<b>Anchor rod and internal threaded anchor FIS E with perforated sleeve FIS H K</b>																	
Max. installation torque $T_{inst,max}$ [Nm]	2				5		2		5								
<b>General installation parameters</b>																	
Edge distance $c_{min}$									60								
Spacing	$s_{min} \parallel$									80							
	$s_{cr} \parallel$									250							
	$s_{min} \perp$									80							
	$s_{cr} \perp$									250							
<b>Drilling method</b>																	
Rotary drilling with carbide drill																	

**Table C44.2:** Group factors

<b>Anchor rod</b>	M6	M8	M6	M8	-	M8	M10	M8	M10	-	M12	M16	M12	M16	M12	M16	
<b>Internal threaded anchor FIS E</b>	-	-	M6	M8		-	-	M10	M12		-			-			
			11x85					15x85									
<b>Perforated sleeve FIS H K</b>	12x50		12x85		16x85			16x130		20x85			20x130		20x200		
Group factors	$\alpha_{q,N} \parallel$									1,9							
	$\alpha_{q,V} \parallel$									0,9							
	$\alpha_{q,N} \perp$									1,0							
	$\alpha_{q,V} \perp$									0,7							

fischer injektion system FIS V masonry

**Performances**

Vertical perforated brick HLz, FZ 7, filled with mineral wool;  
dimensions, installation parameters

**Annex C 44**

**Vertical perforated brick HLz, FZ 7, filled with mineral wool, EN 771-1****Table C45.1:** Installation parameters  
(Push through anchorage with perforated sleeve FIS HK)

Anchor rod		M10	M12	M16
Perforated sleeve FIS H K		18x130/200		22x130/200
<b>Anchor rod with perforated sleeve FIS H K</b>				
Max. installation torque	$T_{inst,max}$ [Nm]	5		
<b>General installation parameters</b>				
Edge distance	$c_{min}$	60		
Spacing	$s_{min} \parallel$	80		
	$s_{cr} \parallel$	250		
	$s_{min} \perp$	80		
	$s_{cr} \perp$	250		
<b>Drilling method</b>				
Rotary drilling with carbide drill				

**Table C45.2:** Group factors

Anchor rod		M10	M12	M16
Perforated sleeve FIS H K		18x130/200		22x130/200
Group factors	$\alpha_{q,N} \parallel$	1,9		
	$\alpha_{q,V} \parallel$	0,9		
	$\alpha_{q,N} \perp$	1,0		
	$\alpha_{q,V} \perp$	0,7		

fischer injektion system FIS V masonry

**Performances**Vertical perforated brick HLz, FZ 7, filled with mineral wool;  
dimensions, installation parameters**Annex C 45**

**Vertical perforated brick HLz, FZ 7, filled with mineral wool, EN 771-1****Table C46.1:** Characteristic resistance under tensile load (Pre-positioned anchorage)

Anchor rod	M6	M8	M6	M8	-	M8	M10	M8	M10	-	M12	M16	M12	M16	M12	M16
Internal threaded anchor FIS E	-	-	-	-	M6 M8 11x85	-	-	-	-	M10 M12 15x85	-	-	-	-	-	-
Perforated sleeve FIS H K	12x50		12x85		16x85			16x130		20x85			20x130		20x200	
<b>Tensile load <math>N_{Rk}</math> [kN] depending on the compressive strength <math>f_b</math> (temperature range 50/80°C)</b>																
compressive strength $f_b$	use category															
4 N/mm <sup>2</sup>	w/w	w/d	0,6	0,75	1,5			2,0		1,2			2,0		2,0	
	d/d		0,6	0,9	1,5			2,0		1,5			2,0		2,5	
6 N/mm <sup>2</sup>	w/w	w/d	0,75	0,9	1,5			2,0		1,5			2,5		2,5	
	d/d		0,9	0,9	2,0			2,5		2,0			2,5		3,0	
8 N/mm <sup>2</sup>	w/w	w/d	0,9	1,2	2,0			2,5		2,0			2,5		3,0	
	d/d		0,9	1,2	2,0			3,0		2,0			3,0		3,5	

**Table C46.2:** Characteristic resistance under tensile load (Push through anchorage)

Anchor rod	M10		M12		M16	
Perforated sleeve FIS H K	18x130/200				22x130/200	
<b>Tensile load <math>N_{Rk}</math> [kN] depending on the compressive strength <math>f_b</math> (temperature range 50/80°C)</b>						
compressive strength $f_b$	use category					
4 N/mm <sup>2</sup>	w/w	w/d	2,0		2,0	
	d/d		2,0		2,0	
6 N/mm <sup>2</sup>	w/w	w/d	2,0		2,5	
	d/d		2,5		2,5	
8 N/mm <sup>2</sup>	w/w	w/d	2,5		2,5	
	d/d		3,0		3,0	

Factor for job site tests and displacements see annex C110.

Factor for temperature range 72/120°C: 0,83

fischer injektion system FIS V masonry

**Performances**

Vertical perforated brick HLz, FZ 7, filled with mineral wool;  
Characteristic resistance under tensile load

**Annex C 46**

**Vertical perforated brick HLz, FZ 7, filled with mineral wool, EN 771-1****Table C47.1:** Characteristic resistance under shear load (Pre-positioned anchorage)

<b>Anchor rod</b>	<b>M6</b>	<b>M8</b>	<b>M6</b>	<b>M8</b>	-	<b>M8</b>	<b>M10</b>	<b>M8</b>	<b>M10</b>	-	<b>M12</b>	<b>M16</b>	<b>M12</b>	<b>M16</b>	<b>M12</b>	<b>M16</b>
<b>Internal threaded anchor FIS E</b>	-	-	<b>M6</b>	<b>M8</b>	<b>11x85</b>	-	-	<b>M10</b>	<b>M12</b>	<b>15x85</b>	-	-	-	-	-	-
<b>Perforated sleeve FIS H K</b>	<b>12x50</b>	<b>12x85</b>	<b>16x85</b>			<b>16x130</b>			<b>20x85</b>			<b>20x130</b>		<b>20x200</b>		

**Shear load  $V_{RK}$  [kN] depending on the compressive strength  $f_b$  (temperature range 50/80°C and 72/120°C)**

compressive strength $f_b$	use category															
<b>4 N/mm<sup>2</sup></b>	w/w	w/d	1,2											1,5		
	d/d															
<b>6 N/mm<sup>2</sup></b>	w/w	w/d	1,5											2,0		
	d/d															
<b>8 N/mm<sup>2</sup></b>	w/w	w/d	1,5											2,5		
	d/d															

**Table C47.2:** Characteristic resistance under shear load (Push through anchorage)

<b>Anchor rod</b>	<b>M10</b>	<b>M12</b>	<b>M16</b>
<b>Perforated sleeve FIS H K</b>	<b>18x130/200</b>		<b>22x130/200</b>

**Shear load  $V_{RK}$  [kN] depending on the compressive strength  $f_b$  (temperature range 50/80°C and 72/120°C)**

compressive strength $f_b$	use category															
<b>4 N/mm<sup>2</sup></b>	w/w	w/d											1,5			
	d/d															
<b>6 N/mm<sup>2</sup></b>	w/w	w/d											2,0			
	d/d															
<b>8 N/mm<sup>2</sup></b>	w/w	w/d											2,5			
	d/d															

Factor for job site tests and displacements see annex C110.

fischer injektion system FIS V masonry

**Performances**Vertical perforated brick HLz, FZ 7, filled with mineral wool;  
Characteristic resistance under shear load**Annex C 47**

**Vertical perforated brick HLz, form B, EN 771-1**

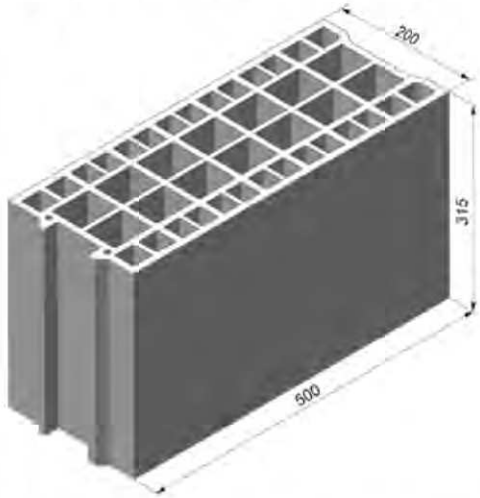

Vertical perforated brick HLz, form B, EN 771-1			
Producer	e.g. Bouyer Leroux		
Nominal dimensions [mm]	length L	width W	height H
	500	200	315
Density $\rho$ [kg/dm <sup>3</sup> ]	≥ 0,6		
Compressive strength $f_b$ [N/mm <sup>2</sup> ]	4 / 6 / 8		
Standard or annex	EN 771-1		

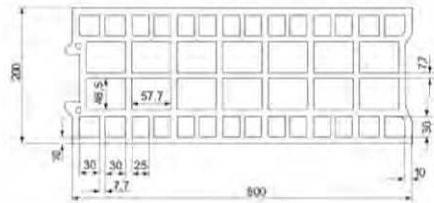

**Table C48.1:** Installation parameters  
(Pre-positioned anchorage with perforated sleeve FIS HK)

<b>Anchor rod</b>	M6	M8	M6	M8	-	M8	M10	M8	M10	-	M12	M16	M12	M16
<b>Internal threaded anchor FIS E</b>	-	-	M6	M8	11x85	-	-	M10	M12	15x85	-	-	-	-
<b>Perforated sleeve FIS H K</b>	12x50	12x85	16x85	16x130	20x85	20x130	-	-	-	-	-	-	-	-
<b>Anchor rod and internal threaded anchor FIS E with perforated sleeve FIS H K</b>														
Max. installation torque $T_{inst,max}$ [Nm]	2													
<b>General installation parameters</b>														
Edge distance $c_{min}$	120													
Spacing	$s_{min} \parallel$	120												
	$s_{cr} \parallel$	500												
	$s_{min} \perp = s_{cr} \perp$	315												
<b>Drilling method</b>														
Hammer drilling with hard metal hammer drill														

**Table C48.2:** Group factors

<b>Anchor rod</b>	M6	M8	M6	M8	-	M8	M10	M8	M10	-	M12	M16	M12	M16
<b>Internal threaded anchor FIS E</b>	-	-	M6	M8	11x85	-	-	M10	M12	15x85	-	-	-	-
<b>Perforated sleeve FIS H K</b>	12x50	12x85	16x85	16x130	20x85	20x130	-	-	-	-	-	-	-	-
Group factors	$\alpha_{q,N} \parallel$	1,3												
	$\alpha_{q,V} \parallel$	1,7												
	$\alpha_{q,N} \perp = \alpha_{q,V} \perp$	2												

fischer injektion system FIS V masonry

**Performances**  
Vertical perforated brick HLz, form B, dimensions, installation parameters

**Annex C 48**

**Vertical perforated brick HLz, form B, EN 771-1****Table C49.1:** Installation parameters  
(Push through anchorage with perforated sleeve FIS HK)

Anchor rod		M10	M12	M16
Perforated sleeve FIS H K		18x130/200		22x130/200
<b>Anchor rod with perforated sleeve FIS H K</b>				
Max. installation torque	$T_{inst,max}$ [Nm]	2		
<b>General installation parameters</b>				
Edge distance	$c_{min}$	120		
Spacing	$s_{min} \parallel$	120		
	$s_{cr} \parallel$	500		
	$s_{min} \perp = s_{cr} \perp$	315		
<b>Drilling method</b>				
Hammer drilling with hard metal hammer drill				

**Table C49.2:** Group factors

Anchor rod		M10	M12	M16
Perforated sleeve FIS H K		18x130/200		22x130/200
Group factors	$\alpha_{q,N} \parallel$	1,3		
	$\alpha_{q,V} \parallel$	1,7		
	$\alpha_{q,N} \perp = \alpha_{q,V} \perp$	2		

fischer injektion system FIS V masonry

**Performances**  
Vertical perforated brick HLz, form B, dimensions, installation parameters**Annex C 49**



**Vertical perforated brick HLz, form B, EN 771-1****Table C50.1:** Characteristic resistance under tensile load (Pre-positioned anchorage)

Anchor rod	M6	M8	M6	M8	-	M8	M10	M8	M10	-	M12	M16	M12	M16	
Internal threaded anchor FIS E	-	-	M6	M8	11x85	-	-	-	-	M10	M12	-	-	-	
Perforated sleeve FIS H K	12x50	12x85	16x85			16x130			20x85			20x130			
<b>Tensile load <math>N_{Rk}</math> [kN] depending on the compressive strength <math>f_b</math> (temperature range 50/80°C)</b>															
compressive strength $f_b$	use category														
4 N/mm <sup>2</sup>	w/w	w/d	0,5	1,5			0,75			1,5			1,5		
	d/d		0,6	1,5			0,9			1,5			2,0		
6 N/mm <sup>2</sup>	w/w	w/d	0,75	2,0			1,2			2,0			2,5		
	d/d		0,9	2,5			1,2			2,5			2,5		
8 N/mm <sup>2</sup>	w/w	w/d	0,9	3,0			1,5			3,0			3,5		
	d/d		1,2	3,0			2,0			3,0			3,5		

**Table C50.2:** Characteristic resistance under tensile load (Push through anchorage)

Anchor rod	M10		M12		M16	
Perforated sleeve FIS H K	18x130/200				22x130/200	
<b>Tensile load <math>N_{Rk}</math> [kN] depending on the compressive strength <math>f_b</math> (temperature range 50/80°C)</b>						
compressive strength $f_b$	use category					
4 N/mm <sup>2</sup>	w/w	w/d	0,75		1,5	
	d/d		0,9		2,0	
6 N/mm <sup>2</sup>	w/w	w/d	1,2		2,5	
	d/d		1,2		2,5	
8 N/mm <sup>2</sup>	w/w	w/d	1,5		3,5	
	d/d		2,0		3,5	

Factor for job site tests and displacements see annex C110.

Factor for temperature range 72/120°C: 0,83

fischer injektion system FIS V masonry

**Performances**

Vertical perforated brick HLz, form B, Characteristic resistance under tensile load

**Annex C 50**

**Vertical perforated brick HLz, form B, EN 771-1****Table C51.1:** Characteristic resistance under shear load (Pre-positioned anchorage)

Anchor rod	M6	M8	M6	M8	-	M8	M10	M8	M10	-	M12	M16	M12	M16
Internal threaded anchor FIS E	-		-		M6	M8	-		-		M10	M12	-	
					11x85						15x85			
Perforated sleeve FIS H K	12x50		12x85		16x85			16x130		20x85			20x130	

**Shear load  $V_{RK}$  [kN] depending on the compressive strength  $f_b$  (temperature range 50/80°C and 72/120°C)**

compressive strength $f_b$	use category									
	4 N/mm <sup>2</sup>	w/w	w/d	1,5				0,9	1,5	2,5
d/d										
6 N/mm <sup>2</sup>	w/w	w/d	2,5				1,5	2,5	3,5	1,5
	d/d									
8 N/mm <sup>2</sup>	w/w	w/d	3,5				2,0	3,5	4,5	2,0
	d/d									

**Table C51.2:** Characteristic resistance under shear load (Push through anchorage)

Anchor rod	M10	M12	M16
Perforated sleeve FIS H K	18x130/200		22x130/200

**Shear load  $V_{RK}$  [kN] depending on the compressive strength  $f_b$  (temperature range 50/80°C and 72/120°C)**

compressive strength $f_b$	use category				
	4 N/mm <sup>2</sup>	w/w	w/d	0,9	
d/d					
6 N/mm <sup>2</sup>	w/w	w/d	1,5		
	d/d				
8 N/mm <sup>2</sup>	w/w	w/d	2,0		
	d/d				

Factor for job site tests and displacements see annex C110

fischer injektion system FIS V masonry

**Performances**

Vertical perforated brick HLz, form B, Characteristic resistance under shear load

**Annex C 51**

**Vertical perforated brick HLz, form B, EN 771-1**

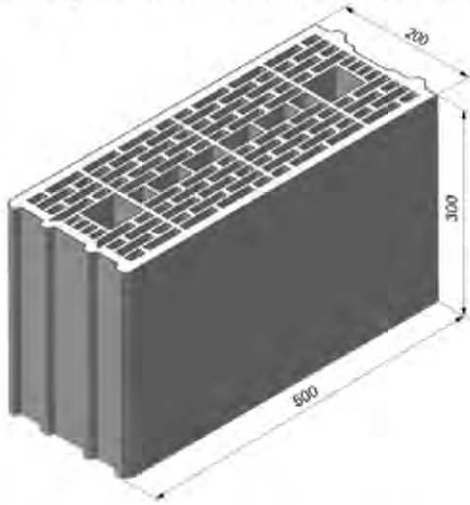

Vertical perforated brick HLz, form B, EN 771-1			
Producer	e.g. Wienerberger		
Nominal dimensions [mm]	length L	width W	height H
	500	200	300
Density $\rho$ [kg/dm <sup>3</sup> ]	≥ 0,7		
Compressive strength $f_b$ [N/mm <sup>2</sup> ]	4 / 6 / 8 / 10		
Standard or annex	EN 771-1		

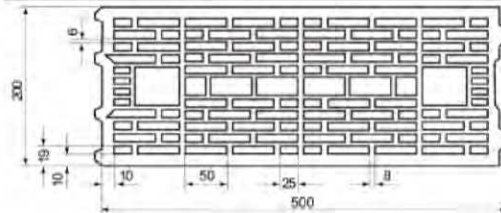

**Table C52.1:** Installation parameters  
(Pre-positioned anchorage with perforated sleeve FIS HK)

<b>Anchor rod</b>	M6	M8	M6	M8	-	M8	M10	M8	M10	--	M12	M16	M12	M16
<b>Internal threaded anchor FIS E</b>	-	-	M6		M8	-	-	M10		M12	-	-	-	-
			11x85				15x85							
<b>Perforated sleeve FIS H K</b>	12x50		12x85		16x85			16x130		20x85		20x130		
<b>Anchor rod and internal threaded anchor FIS E with perforated sleeve FIS H K</b>														
Max. installation torque $T_{inst,max}$ [Nm]	2													
<b>General installation parameters</b>														
Edge distance $c_{min}$	50													
Spacing	$s_{min} \parallel$	100												
	$s_{cr} \parallel$	500												
	$s_{min} \perp = s_{cr} \perp$	300												
<b>Drilling method</b>														
Hammer drilling with hard metal hammer drill														

**Table C52.2:** Group factors

<b>Anchor rod</b>	M6	M8	M6	M8	-	M8	M10	M8	M10	-	M12	M16	M12	M16
<b>Internal threaded anchor FIS E</b>	-	-	M6		M8	-	-	M10		M12	-	-	-	-
			11x85				15x85							
<b>Perforated sleeve FIS H K</b>	12x50		12x85		16x85			16x130		20x85		20x130		
Group factors	$\alpha_{q,N} \parallel$	1,4												
	$\alpha_{q,V} \parallel$	2												
	$\alpha_{q,N} \perp = \alpha_{q,V} \perp$													

fischer injektion system FIS V masonry

**Performances**  
Vertical perforated brick HLz, form B, dimensions, installation parameters

**Annex C 52**

**Vertical perforated brick HLz, form B, EN 771-1****Table C53.1:** Installation parameters  
(Push through anchorage with perforated sleeve FIS HK)

Anchor rod		M10	M12	M16
Perforated sleeve FIS H K		18x130/200		22x130/200
<b>Anchor rod with perforated sleeve FIS H K</b>				
Max. installation torque	$T_{inst,max}$ [Nm]	2		
<b>General installation parameters</b>				
Edge distance	$c_{min}$	80		
Spacing	$s_{min \parallel}$	100		
	$s_{cr \parallel}$	500		
	$s_{min \perp} = s_{cr \perp}$	300		
<b>Drilling method</b>				
Hammer drilling with hard metal hammer drill				

**Table C53.2:** Group factors

Anchor rod		M10	M12	M16
Perforated sleeve FIS H K		18x130/200		22x130/200
Group factors	$\alpha_{q,N \parallel}$	1,4		
	$\alpha_{q,V \parallel}$	2		
	$\alpha_{q,N \perp} = \alpha_{q,V \perp}$	2		

fischer injektion system FIS V masonry

**Performances**  
Vertical perforated brick HLz, form B, dimensions, installation parameters**Annex C 53**

**Vertical perforated brick HLz, form B, EN 771-1****Table C54.1:** Characteristic resistance under tensile load (Pre-positioned anchorage)

Anchor rod	M6	M8	M6	M8	-	M8	M10	M8	M10	-	M12	M16	M12	M16
Internal threaded anchor FIS E	-	-	-	-	M6	M8	-	-	-	M10	M12	-	-	-
Perforated sleeve FIS H K	12x50	12x85	12x85	12x85	11x85	11x85	16x85	16x130	16x130	20x85	20x85	20x85	20x130	20x130
<b>Tensile load <math>N_{Rk}</math> [kN] depending on the compressive strength <math>f_b</math> (temperature range 50/80°C)</b>														
compressive strength $f_b$	use category													
4 N/mm <sup>2</sup>	w/w	w/d	0,5		0,6		1,2		0,75		1,5			
	d/d		0,6		0,75		1,2		0,9		1,5			
6 N/mm <sup>2</sup>	w/w	w/d	0,75		0,9		1,5		1,2		2,0			
	d/d		0,9		1,2		2,0		1,2		2,5			
8 N/mm <sup>2</sup>	w/w	w/d	0,9		1,2		2,0		1,5		2,5			
	d/d		1,2		1,5		2,5		1,5		3,0			
10 N/mm <sup>2</sup>	w/w	w/d	1,2		1,5		2,5		2,0		3,5			
	d/d		1,5		2,0		3,0		2,0		4,0			

**Table C54.2:** Characteristic resistance under tensile load (Push through anchorage)

Anchor rod	M10	M12	M16
Perforated sleeve FIS H K	18x130/200	18x130/200	22x130/200
<b>Tensile load <math>N_{Rk}</math> [kN] depending on the compressive strength <math>f_b</math> (temperature range 50/80°C)</b>			
compressive strength $f_b$	use category		
4 N/mm <sup>2</sup>	w/w	w/d	1,2
	d/d		1,2
6 N/mm <sup>2</sup>	w/w	w/d	1,5
	d/d		2,0
8 N/mm <sup>2</sup>	w/w	w/d	2,0
	d/d		2,5
10 N/mm <sup>2</sup>	w/w	w/d	2,5
	d/d		3,0

Factor for job site tests and displacements see annex C110

Factor for temperature range 72/120°C: 0,83

fischer injektion system FIS V masonry

**Performances**

Vertical perforated brick HLz, form B, Characteristic resistance under tensile load

**Annex C 54**

<b>Vertical perforated brick HLz, form B, EN 771-1</b>														
<b>Table C55.1: Characteristic resistance under shear load (Pre-positioned anchorage)</b>														
Anchor rod	M6	M8	M6	M8	-	M8	M10	M8	M10	-	M12	M16	M12	M16
Internal threaded anchor FIS E	-		-		M6	M8	-		-		M10	M12	-	
					11x85						15x85			
Perforated sleeve FIS H K	12x50		12x85		16x85			16x130		20x85			20x130	
Shear load $V_{RK}$ [kN] depending on the compressive strength $f_b$ (temperature range 50/80°C and 72/120°C)														
compressive strength $f_b$	use category													
4 N/mm <sup>2</sup>	w/w	w/d	0,9	1,2	0,9	1,2	0,6	2,0	0,6					
	d/d													
6 N/mm <sup>2</sup>	w/w	w/d	1,2	1,5	1,2	1,5	0,9	3,0	0,9					
	d/d													
8 N/mm <sup>2</sup>	w/w	w/d	1,5	2,0	1,5	2,0	1,2	4,0	1,2					
	d/d													
10 N/mm <sup>2</sup>	w/w	w/d	2,0	3,0	2,0	3,0	1,5	5,0	1,5					
	d/d													
Table C55.2: Characteristic resistance under shear load (Push through anchorage)														
Anchor rod	M10				M12				M16					
Perforated sleeve FIS H K	18x130/200								22x130/200					
Shear load $V_{RK}$ [kN] depending on the compressive strength $f_b$ (temperature range 50/80°C and 72/120°C)														
compressive strength $f_b$	use category													
4 N/mm <sup>2</sup>	w/w	w/d	0,6											
	d/d													
6 N/mm <sup>2</sup>	w/w	w/d	0,9											
	d/d													
8 N/mm <sup>2</sup>	w/w	w/d	1,2											
	d/d													
10 N/mm <sup>2</sup>	w/w	w/d	1,5											
	d/d													
Factor for job site tests and displacements see annex C110														
fischer injektion system FIS V masonry											<b>Annex C 55</b>			
<b>Performances</b> Vertical perforated brick HLz, form B, Characteristic resistance under shear load														

**Vertical perforated brick HLz, form B, EN 771-1**

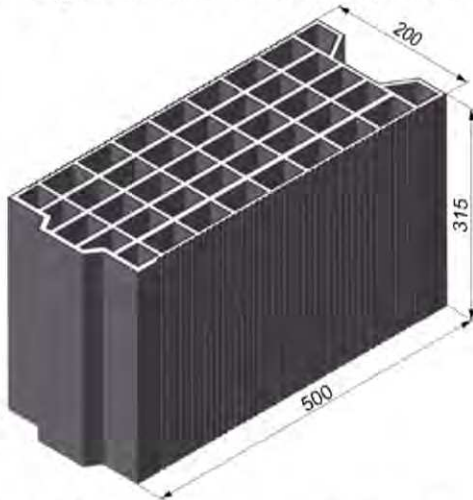

Vertical perforated brick HLz, form B, EN 771-1			
Producer	e.g. Terreal		
Nominal dimensions [mm]	length L	width W	height H
	500	200	315
Density $\rho$ [kg/dm <sup>3</sup> ]	≥ 0,7		
Compressive strength $f_b$ [N/mm <sup>2</sup> ]	2 / 4 / 6 / 8		
Standard or annex	EN 771-1		

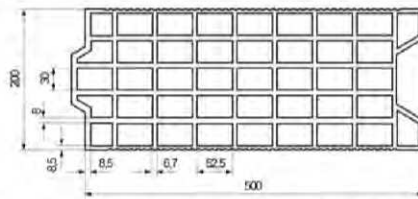

**Table C56.1:** Installation parameters  
(Pre-positioned anchorage with perforated sleeve FIS HK)

<b>Anchor rod</b>	M6	M8	M6	M8	-	M8	M10	M8	M10	-	M12	M16	M12	M16	
<b>Internal threaded anchor FIS E</b>	-	-	M6	M8	11x85	-	-	M10	M12	15x85	-	-	-	-	
<b>Perforated sleeve FIS H K</b>	12x50		12x85		16x85		16x130		20x85		20x130				
<b>Anchor rod and internal threaded anchor FIS E with perforated sleeve FIS H K</b>															
Max. installation torque	$T_{inst,max}$	[Nm]	2												
<b>General installation parameters</b>															
Edge distance	$c_{min}$		50				80		50		80				
Spacing	$s_{min} \parallel$	[mm]					100								
	$s_{cr} \parallel$						500								
	$s_{min} \perp$						100								
	$s_{cr} \perp$						315								
<b>Drilling method</b>															
Hammer drilling with hard metal hammer drill															

**Table C56.2:** Group factors

<b>Anchor rod</b>	M6	M8	M6	M8	-	M8	M10	M8	M10	-	M12	M16	M12	M16	
<b>Internal threaded anchor FIS E</b>	-	-	M6	M8	11x85	-	-	M10	M12	15x85	-	-	-	-	
<b>Perforated sleeve FIS H K</b>	12x50		12x85		16x85		16x130		20x85		20x130				
Group factors	$\alpha_{q,N} \parallel$	[-]					1,1								
	$\alpha_{q,V} \parallel$						1,2								
	$\alpha_{q,N} \perp$						1,1								
	$\alpha_{q,V} \perp$						1,2								

fischer injektion system FIS V masonry

**Performances**

Vertical perforated brick HLz, form B, dimensions, installation parameters

**Annex C 56**

**Vertical perforated brick HLz, form B, EN 771-1****Table C57.1:** Installation parameters  
(Push through anchorage with perforated sleeve FIS HK)

Anchor rod		M10	M12	M16
Perforated sleeve FIS H K		18x130/200		22x130/200
<b>Anchor rod with perforated sleeve FIS H K</b>				
Max. installation torque	$T_{inst,max}$ [Nm]	2		
<b>General installation parameters</b>				
Edge distance	$c_{min}$	80		
Spacing	$s_{min \parallel}$	100		
	$s_{cr \parallel}$ [mm]	500		
	$s_{min \perp}$	100		
	$s_{cr \perp}$	315		
<b>Drilling method</b>				
Hammer drilling with hard metal hammer drill				

**Table C57.2:** Group factors

Anchor rod		M10	M12	M16
Perforated sleeve FIS H K		18x130/200		22x130/200
Group factors	$\alpha_{a,N \parallel}$	1,1		
	$\alpha_{a,V \parallel}$	1,2		
	$\alpha_{a,N \perp}$	1,1		
	$\alpha_{a,V \perp}$	1,2		

fischer injektion system FIS V masonry

**Performances**  
Vertical perforated brick HLz, form B, dimensions, installation parameters**Annex C 57**



**Vertical perforated brick HLz, form B, EN 771-1****Table C58.1:** Characteristic resistance under tensile load (Pre-positioned anchorage)

<b>Anchor rod</b>	<b>M6</b>	<b>M8</b>	<b>M6</b>	<b>M8</b>	<b>-</b>	<b>M8</b>	<b>M10</b>	<b>M8</b>	<b>M10</b>	<b>-</b>	<b>M12</b>	<b>M16</b>	<b>M12</b>	<b>M16</b>
<b>Internal threaded anchor FIS E</b>	-	-	<b>M6</b>	<b>M8</b>	<b>11x85</b>	-	-	-	<b>M10</b>	<b>M12</b>	-	-	-	-
<b>Perforated sleeve FIS H K</b>	<b>12x50</b>	<b>12x85</b>	<b>16x85</b>				<b>16x130</b>		<b>20x85</b>			<b>20x130</b>		

**Tensile load  $N_{Rk}$  [kN] depending on the compressive strength  $f_b$  (temperature range 50/80°C)**

compressive strength $f_b$	use category													
<b>2 N/mm<sup>2</sup></b>	w/w	w/d	0,5											
	d/d		0,5				0,6		0,5				0,6	
<b>4 N/mm<sup>2</sup></b>	w/w	w/d	0,9											
	d/d		0,9		1,2									
<b>6 N/mm<sup>2</sup></b>	w/w	w/d	1,5											
	d/d		1,5											
<b>8 N/mm<sup>2</sup></b>	w/w	w/d	2,0											
	d/d		2,0											

**Table C58.2:** Characteristic resistance under tensile load (Push through anchorage)

<b>Anchor rod</b>	<b>M10</b>	<b>M12</b>	<b>M16</b>
<b>Perforated sleeve FIS H K</b>	<b>18x130/200</b>		<b>22x130/200</b>

**Tensile load  $N_{Rk}$  [kN] depending on the compressive strength  $f_b$  (temperature range 50/80°C)**

compressive strength $f_b$	use category													
<b>2 N/mm<sup>2</sup></b>	w/w	w/d	0,5											
	d/d		0,6											
<b>4 N/mm<sup>2</sup></b>	w/w	w/d	0,9											
	d/d		1,2											
<b>6 N/mm<sup>2</sup></b>	w/w	w/d	1,5											
	d/d		1,5											
<b>8 N/mm<sup>2</sup></b>	w/w	w/d	2,0											
	d/d		2,0											

Factor for job site tests and displacements see annex C110

Factor for temperature range 72/120°C: 0,83

fischer injektion system FIS V masonry

**Performances**

Vertical perforated brick HLz, form B, Characteristic resistance under tensile load

**Annex C 58**

<b>Vertical perforated brick HLz, form B, EN 771-1</b>																		
<b>Table C59.1: Characteristic resistance under shear load (Pre-positioned anchorage)</b>																		
Anchor rod		M6	M8	M6	M8	-		M8	M10	M8	M10	-		M12	M16	M12	M16	
Internal threaded anchor FIS E		-		-		M6	M8	-		-		M10	M12	-		-		
				11x85								15x85						
Perforated sleeve FIS H K		12x50		12x85		16x85				16x130		20x85		20x130				
<b>Shear load <math>V_{RK}</math> [kN] depending on the compressive strength <math>f_b</math> (temperature range 50/80°C and 72/120°C)</b>																		
compressive strength $f_b$		use category																
2 N/mm <sup>2</sup>	w/w	w/d	0,3	0,6	0,3	0,6	0,6	0,6	0,6	0,6	0,6	0,9	0,9	0,9	0,9	0,9	0,75	
	d/d	d/d																
4 N/mm <sup>2</sup>	w/w	w/d	0,75	1,2	0,75	1,2	1,2	1,2	1,2	1,2	1,2	2,0	2,0	2,0	2,0	2,0	1,5	
	d/d	d/d																
6 N/mm <sup>2</sup>	w/w	w/d	0,9	2,0	0,9	2,0	2,0	1,5	1,5	1,5	1,5	3,0	3,0	3,0	3,0	3,0	2,0	
	d/d	d/d																
8 N/mm <sup>2</sup>	w/w	w/d	1,5	2,5	1,5	2,5	2,5	2,0	2,0	2,0	2,0	4,0	4,0	4,0	4,0	4,0	3,0	
	d/d	d/d																
<b>Table C59.2: Characteristic resistance under shear load (Push through anchorage)</b>																		
Anchor rod		M10				M12				M16								
Perforated sleeve FIS H K		18x130/200								22x130/200								
<b>Shear load <math>V_{RK}</math> [kN] depending on the compressive strength <math>f_b</math> (temperature range 50/80°C and 72/120°C)</b>																		
compressive strength $f_b$		use category																
2 N/mm <sup>2</sup>	w/w	w/d	0,6								0,75							
	d/d	d/d																
4 N/mm <sup>2</sup>	w/w	w/d	1,2								1,5							
	d/d	d/d																
6 N/mm <sup>2</sup>	w/w	w/d	1,5								2,0							
	d/d	d/d																
8 N/mm <sup>2</sup>	w/w	w/d	2,0								3,0							
	d/d	d/d																
Factor for job site tests and displacements see annex C110																		
fischer injektion system FIS V masonry																<b>Annex C 59</b>		
<b>Performances</b>		Vertical perforated brick HLz, form B, Characteristic resistance under shear load																

**Vertical perforated brick HLz, form B, EN 771-1**

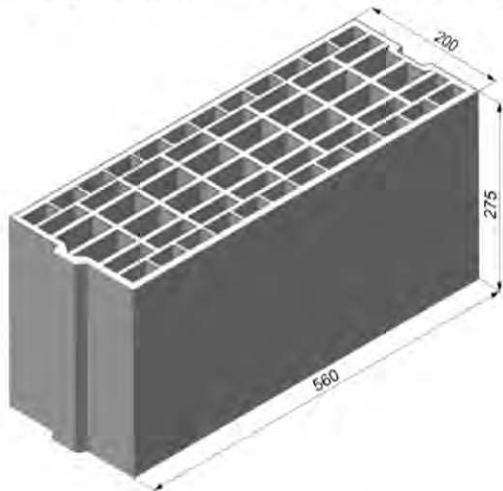

Vertical perforated brick HLz, form B, EN 771-1			
Producer	e.g. Imery		
Nominal dimensions [mm]	length L	width W	height H
	560	200	275
Density $\rho$ [kg/dm <sup>3</sup> ]	≥ 0,7		
Compressive strength $f_b$ [N/mm <sup>2</sup> ]	4 / 6 / 8		
Standard or annex	EN 771-1		

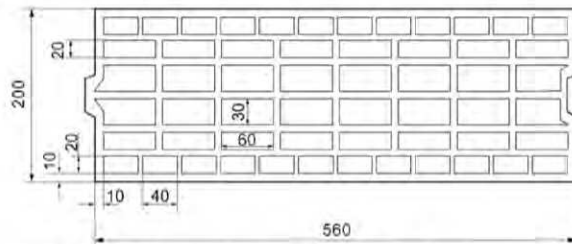

**Table C60.1:** Installation parameters

Anchor rod	M8	M10	M10	M12	M12	M16	M16
Perforated sleeve FIS H K	16x130		18x130/200		20x130		22x130/200
<b>Anchor rod with perforated sleeve FIS H K</b>							
Max. installation torque $T_{inst,max}$ [Nm]	2						
<b>General installation parameters</b>							
Edge distance $c_{min}$	80						
Spacing	$s_{min \parallel} = s_{cr \parallel}$ [mm]		560				
	$s_{min \perp} = s_{cr \perp}$		275				
<b>Drilling method</b>							
Hammer drilling with hard metal hammer drill							

**Table C60.2:** Group factors

Anchor rod	M8	M10	M10	M12	M12	M16	M16
Perforated sleeve FIS H K	16x130		18x130/200		20x130		22x130/200
Group factors	$\alpha_{q,N \parallel}$	[-]	2				
	$\alpha_{q,V \parallel}$						
	$\alpha_{q,N \perp}$						
	$\alpha_{q,V \perp}$						

fischer injektion system FIS V masonry

**Performances**  
Vertical perforated brick HLz, form B, dimensions, installation parameters

**Annex C 60**

**Vertical perforated brick HLz, form B, EN 771-1****Table C61.1:** Characteristic resistance under tensile load

Anchor rod		M8	M10	M10	M12	M12	M16	M16
Perforated sleeve FIS H K		16x130		18x130/200		20x130		22x130/200
<b>Tensile load <math>N_{Rk}</math> [kN] depending on the compressive strength <math>f_b</math> (temperature range 50/80°C)</b>								
compressive strength $f_b$	use category							
	w/w	w/d	0,9			1,2		
4 N/mm <sup>2</sup>	d/d		1,2			1,5		
	w/w	w/d	1,5			2,0		
6 N/mm <sup>2</sup>	d/d		1,5			2,0		
	w/w	w/d	2,0			2,5		
8 N/mm <sup>2</sup>	d/d		2,5			3,0		

Factor for temperature range 72/120°C: 0,83

**Table C61.2:** Characteristic resistance under shear load

Anchor rod		M8	M10	M10	M12	M12	M16	M16
Perforated sleeve FIS H K		16x130		18x130/200		20x130		22x130/200
<b>Shear load <math>V_{Rk}</math> [kN] depending on the compressive strength <math>f_b</math> (temperature range 50/80°C and 72/120°C)</b>								
compressive strength $f_b$	use category							
	w/w	w/d	0,9					
4 N/mm <sup>2</sup>	d/d					0,9		
	w/w	w/d	1,5					
6 N/mm <sup>2</sup>	d/d					1,5		
	w/w	w/d	2,0					
8 N/mm <sup>2</sup>	d/d					2,0		

Factor for job site tests and displacements see annex C110

fischer injektion system FIS V masonry

**Performances**Vertical perforated brick HLz, form B,  
Characteristic resistance under tensile and shear load**Annex C 61**

**Vertical perforated brick HLz, EN 771-1**

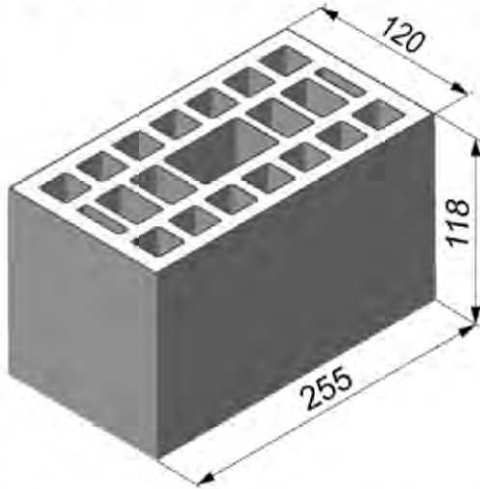

Vertical perforated brick HLz, EN 771-1			
Producer	e.g. Wienerberger		
Nominal dimensions [mm]	length L	width W	height H
	255	120	118
Density $\rho$ [kg/dm <sup>3</sup> ]	≥ 1,0		
Compressive strength $f_b$ [N/mm <sup>2</sup> ]	2 / 4 / 6 / 8 / 10 / 12		
Standard or annex	EN 771-1		

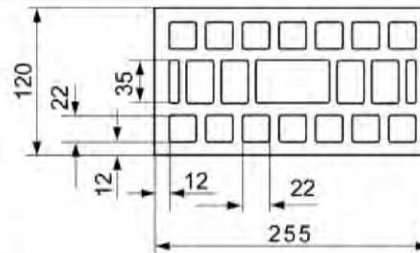

**Table C62.1:** Installation parameters

<b>Anchor rod</b>	M6	M8	M6	M8	-	M8	M10	-	M12	M16
<b>Internal threaded anchor FIS E</b>	-	-	-	-	M6	M8	-	M10	M12	-
					11x85			15x85		
<b>Perforated sleeve FIS H K</b>	12x50		12x85		16x85			20x85		
<b>Anchor rod and internal threaded anchor FIS E with perforated sleeve FIS H K</b>										
Max. installation torque $T_{inst,max}$ [Nm]	2									
<b>General installation parameters</b>										
Edge distance $c_{min}$	60									
Spacing $s_{cr}$	$s_{cr \parallel} = s_{min \parallel}$									
	$s_{cr \perp} = s_{min \perp}$									
	255									
	120									
<b>Drilling method</b>										
Hammer drilling with hard metal hammer drill										

**Table C62.2:** Group factors

<b>Anchor rod</b>	M6	M8	M6	M8	-	M8	M10	-	M12	M16
<b>Internal threaded anchor FIS E</b>	-	-	-	-	M6	M8	-	M10	M12	-
					11x85			15x85		
<b>Perforated sleeve FIS H K</b>	12x50		12x85		16x85			20x85		
Group factors	$\alpha_{q,N \parallel}$	[-]	2							
	$\alpha_{q,V \parallel}$									
	$\alpha_{q,N \perp}$									
	$\alpha_{q,V \perp}$									

fischer injektion system FIS V masonry

**Performances**  
Vertical perforated brick HLz, dimensions, installation parameters

**Annex C 62**

**Vertical perforated brick HLz, EN 771-1****Table C63.1:** Characteristic resistance under tensile load

Anchor rod		M6	M8	M6	M8	-		M8	M10	-		M12	M16
Internal threaded anchor FIS E		-		-		M6	M8	-		M10	M12	-	
						11x85				15x85			
Perforated sleeve FIS H K		12x50		12x85		16x85				20x85			
<b>Tensile load <math>N_{Rk}</math> [kN] depending on the compressive strength <math>f_b</math> (temperature range 50/80°C)</b>													
compressive strength $f_b$	use category												
2 N/mm <sup>2</sup>	w/w	w/d	0,4		0,5				-				
	d/d		0,5		0,5				-				
4 N/mm <sup>2</sup>	w/w	w/d	0,9		0,9				0,5				
	d/d		0,9		1,2				0,5				
6 N/mm <sup>2</sup>	w/w	w/d	1,2		1,5				0,75				
	d/d		1,5		1,5				0,75				
8 N/mm <sup>2</sup>	w/w	w/d	1,5		2,0				0,9				
	d/d		2,0		2,0				0,9				
10 N/mm <sup>2</sup>	w/w	w/d	2,0		2,5				1,2				
	d/d		2,5		2,5				1,2				
12 N/mm <sup>2</sup>	w/w	w/d	2,5		3,0				1,5				
	d/d		3,0		3,5				1,5				

Factor for job site tests and displacements see annex C110

Factor for temperature range 72/120°C: 0,83

fischer injektion system FIS V masonry

**Performances**

Vertical perforated brick HLz, Characteristic resistance under tensile load

**Annex C 63**

**Vertical perforated brick HLz, EN 771-1****Table C64.1:** Characteristic resistance under shear load

Anchor rod	M6	M8	M6	M8	-	M8	M10	-	M12	M16
Internal threaded anchor FIS E	-		-		M6	M8	-		M10	M12
					11x85				15x85	
Perforated sleeve FIS H K	12x50		12x85		16x85			20x85		
<b>Shear load <math>V_{RK}</math> [kN] depending on the compressive strength <math>f_b</math> (temperature range 50/80°C and 72/120°C)</b>										
compressive strength $f_b$	use category									
2 N/mm <sup>2</sup>	w/w	w/d	0,6	0,75	0,6	0,75	0,9			
	d/d									
4 N/mm <sup>2</sup>	w/w	w/d	1,2	1,5	1,2	1,5	2,0			
	d/d									
6 N/mm <sup>2</sup>	w/w	w/d	2,0	2,0	2,0	2,0	2,5			
	d/d									
8 N/mm <sup>2</sup>	w/w	w/d	2,5	3,0	2,5	3,0	3,5			
	d/d									
10 N/mm <sup>2</sup>	w/w	w/d	3,0	3,5	3,0	3,5	4,5			
	d/d									
12 N/mm <sup>2</sup>	w/w	w/d	4,0	4,5	4,0	4,5	5,5			
	d/d									

Factor for job site tests and displacements see annex C110

fischer injektion system FIS V masonry

**Performances**

Vertical perforated brick HLz, Characteristic resistance under shear load

**Annex C 64**

**Vertical perforated brick HLz, EN 771-1**

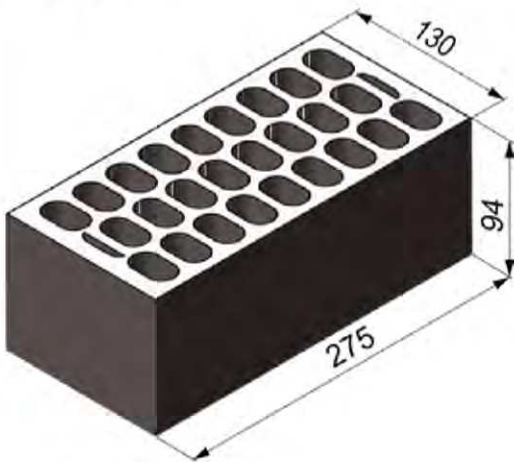

Vertical perforated brick HLz, EN 771-1			
Producer	e.g. Ceramica Farreny S.A.		
Nominal dimensions [mm]	length L	width W	height H
	275	130	94
Density $\rho$ [kg/dm <sup>3</sup> ]	≥ 0,8		
Compressive strength $f_b$ [N/mm <sup>2</sup> ]	6 / 8 / 12 / 16 / 20		
Standard or annex	EN 771-1		

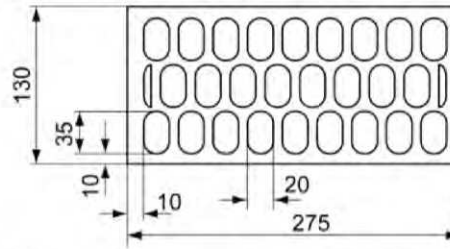

**Table C65.1:** Installation parameters

<b>Anchor rod</b>	M6	M8	M6	M8	-	M8	M10	-	M12	M16
<b>Internal threaded anchor FIS E</b>	-		-		M6	M8	-		M10	M12
	-		-		11x85		-		15x85	
<b>Perforated sleeve FIS H K</b>	12x50		12x85		16x85			20x85		
<b>Anchor rod and internal threaded anchor FIS E with perforated sleeve FIS H K</b>										
Max. installation torque $T_{inst,max}$ [Nm]	2									
<b>General installation parameters</b>										
Edge distance $c_{min}$	100					120				
Spacing $s_{cr \parallel} = s_{min \parallel}$ [mm]	275									
	$s_{cr \perp} = s_{min \perp}$	95								
<b>Drilling method</b>										
Hammer drilling with hard metal hammer drill										

**Table C65.2:** Group factors

<b>Anchor rod</b>	M6	M8	M6	M8	-	M8	M10	-	M12	M16
<b>Internal threaded anchor FIS E</b>	-		-		M6	M8	-		M10	M12
	-		-		11x85		-		15x85	
<b>Perforated sleeve FIS H K</b>	12x50		12x85		16x85			20x85		
Group factors [-]	$\alpha_{q,N \parallel}$	2								
	$\alpha_{q,V \parallel}$									
	$\alpha_{q,N \perp}$									
	$\alpha_{q,V \perp}$									

fischer injektion system FIS V masonry

**Performances**  
Vertical perforated brick HLz, dimensions, installation parameters

**Annex C 65**



<b>Vertical perforated brick HLz, EN 771-1</b>										
<b>Table C66.1: Characteristic resistance under tensile load</b>										
Anchor rod	M6	M8	M6	M8	-	M8	M10	-	M12	M16
Internal threaded anchor FIS E	-		-		M6	M8	-		M10	M12
					11x85				15x85	
Perforated sleeve FIS H K	12x50		12x85		16x85			20x85		
Tensile load $N_{Rk}$ [kN] depending on the compressive strength $f_b$ (temperature range 50/80°C)										
compressive strength $f_b$	use category									
6 N/mm <sup>2</sup>	w/w	w/d	0,4		0,9					
	d/d		0,4		0,9					
8 N/mm <sup>2</sup>	w/w	w/d	0,5		1,2					
	d/d		0,6		1,2					
12 N/mm <sup>2</sup>	w/w	w/d	0,75		1,5					
	d/d		0,9		2,0					
16 N/mm <sup>2</sup>	w/w	w/d	0,9		2,0					
	d/d		1,2		2,5					
20 N/mm <sup>2</sup>	w/w	w/d	1,2		3,0					
	d/d		1,5		3,0					
Factor for temperature range 72/120°C: 0,83										
<b>Table C66.2: Characteristic resistance under shear load</b>										
Anchor rod	M6	M8	M6	M8	-	M8	M10	-	M12	M16
Internal threaded anchor FIS E	-		-		M6	M8	-		M10	M12
					11x85				15x85	
Perforated sleeve FIS H K	12x50		12x85		16x85			20x85		
Shear load $V_{Rk}$ [kN] depending on the compressive strength $f_b$ (temperature range 50/80°C and 72/120°C)										
compressive strength $f_b$	use category									
6 N/mm <sup>2</sup>	w/w	w/d	1,2		1,2					
	d/d									
8 N/mm <sup>2</sup>	w/w	w/d	1,5		1,5					
	d/d									
12 N/mm <sup>2</sup>	w/w	w/d	2,0		2,5					
	d/d									
16 N/mm <sup>2</sup>	w/w	w/d	3,0		3,0					
	d/d									
20 N/mm <sup>2</sup>	w/w	w/d	4,0		4,0					
	d/d									
Factor for job site tests and displacements see annex C110										
fischer injektion system FIS V masonry									<b>Annex C 66</b>	
<b>Performances</b> Vertical perforated brick HLz, Characteristic resistance under tensile and shear load										

**Vertical perforated brick HLz, EN 771-1**

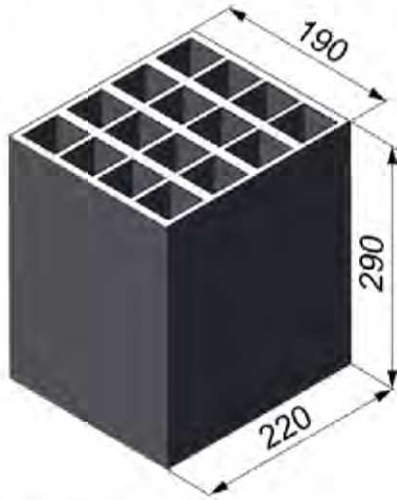

Vertical perforated brick HLz, EN 771-1			
Producer	e.g. Perceram		
Nominal dimensions [mm]	length L	width W	height H
	220	190	290
Density $\rho$ [kg/dm <sup>3</sup> ]	≥ 0,7		
Compressive strength $f_b$ [N/mm <sup>2</sup> ]	6 / 8 / 10		
Standard or annex	EN 771-1		

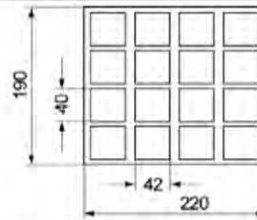

**Table C67.1:** Installation parameters  
(Pre-positioned anchorage with perforated sleeve FIS HK)

<b>Anchor rod</b>	M6	M8	M6	M8	-	M8	M10	M8	M10	-	M12	M16	M12	M16
<b>Internal threaded anchor FIS E</b>	-	-	M6	M8	-	-	-	M10	M12	-	-	-	-	-
			11x85					15x85						
<b>Perforated sleeve FIS H K</b>	12x50	12x85	16x85		16x130		20x85		20x130					
<b>Anchor rod and internal threaded anchor FIS E with perforated sleeve FIS H K</b>														
Max. installation torque $T_{inst,max}$ [Nm]	2													
<b>General installation parameters</b>														
Edge distance $c_{min}$	110													
Spacing $s_{min} \parallel = s_{cr} \parallel$	220													
	$s_{min} \perp = s_{cr} \perp$	290												
<b>Drilling method</b>														
Hammer drilling with hard metal hammer drill														

**Table C67.2:** Group factors

<b>Anchor rod</b>	M6	M8	M6	M8	-	M8	M10	M8	M10	-	M12	M16	M12	M16
<b>Internal threaded anchor FIS E</b>	-	-	M6	M8	-	-	-	M10	M12	-	-	-	-	-
			11x85					15x85						
<b>Perforated sleeve FIS H K</b>	12x50	12x85	16x85		16x130		20x85		20x130					
Group factors	$\alpha_{q,N} \parallel$	[-]	2											
	$\alpha_{q,V} \parallel$													
	$\alpha_{q,N} \perp$													
	$\alpha_{q,V} \perp$													

fischer injektion system FIS V masonry

**Performances**  
Vertical perforated brick HLz, dimensions, installation parameters

**Annex C 67**

<b>Vertical perforated brick HLz, EN 771-1</b>			
<b>Table C68.1:</b> Installation parameters (Push through anchorage with perforated sleeve FIS HK)			
<b>Anchor rod</b>	<b>M10</b>	<b>M12</b>	<b>M16</b>
<b>Perforated sleeve FIS H K</b>	<b>18x130/200</b>		<b>22x130/200</b>
<b>Anchor rod with perforated sleeve FIS H K</b>			
Max. installation torque	$T_{inst,max}$ [Nm]	2	
<b>General installation parameters</b>			
Edge distance	$c_{min}$	110	
Spacing	$s_{min \parallel} = s_{cr \parallel}$	220	
	$s_{min \perp} = s_{cr \perp}$	290	
<b>Drilling method</b>			
Hammer drilling with hard metal hammer drill			
<b>Table C68.2:</b> Group factors			
<b>Anchor rod</b>	<b>M10</b>	<b>M12</b>	<b>M16</b>
<b>Perforated sleeve FIS H K</b>	<b>18x130/200</b>		<b>22x130/200</b>
Group factors	$\alpha_{g,N \parallel}$	[-]	2
	$\alpha_{g,V \parallel}$		
	$\alpha_{g,N \perp}$		
	$\alpha_{g,V \perp}$		
fischer injektion system FIS V masonry			<b>Annex C 68</b>
<b>Performances</b> Vertical perforated brick HLz, dimensions, installation parameters			

**Vertical perforated brick HLz, EN 771-1****Table C69.1:** Characteristic resistance under tensile load (Pre-positioned anchorage)

Anchor rod	M6	M8	M6	M8	-	M8	M10	M8	M10	-	M12	M16	M12	M16
Internal threaded anchor FIS E	-	-	M6	M8	11x85	-	-	-	-	M10	M12	-	-	-
Perforated sleeve FIS H K	12x50	12x85	16x85			16x130			20x85			20x130		
<b>Tensile load <math>N_{Rk}</math> [kN] depending on the compressive strength <math>f_b</math> (temperature range 50/80°C)</b>														
compressive strength $f_b$	use category													
6 N/mm <sup>2</sup>	w/w	w/d	0,3	1,2	1,2			1,5	1,2			1,5		
	d/d		0,4	1,5	1,5			1,5	1,5			1,5		
8 N/mm <sup>2</sup>	w/w	w/d	0,5	1,5	1,5			2,0	1,5			2,0		
	d/d		0,5	2,0	2,0			2,5	2,0			2,5		
10 N/mm <sup>2</sup>	w/w	w/d	0,6	2,0	2,0			2,5	2,0			2,5		
	d/d		0,6	2,5	2,5			3,0	2,5			3,0		

**Table C69.2:** Characteristic resistance under tensile load (Push through anchorage)

Anchor rod	M10		M12		M16	
Perforated sleeve FIS H K	18x130/200				22x130/200	
<b>Tensile load <math>N_{Rk}</math> [kN] depending on the compressive strength <math>f_b</math> (temperature range 50/80°C)</b>						
compressive strength $f_b$	use category					
6 N/mm <sup>2</sup>	w/w	w/d	1,5			
	d/d		1,5			
8 N/mm <sup>2</sup>	w/w	w/d	2,0			
	d/d		2,5			
10 N/mm <sup>2</sup>	w/w	w/d	2,5			
	d/d		3,0			

Factor for job site tests and displacements see annex C110

Factor for temperature range 72/120°C: 0,83

fischer injektion system FIS V masonry

**Performances**

Vertical perforated brick HLz, Characteristic resistance under tensile load

**Annex C 69**

**Vertical perforated brick HLz, EN 771-1****Table C70.1:** Characteristic resistance under shear load (Pre-positioned anchorage)

Anchor rod	M6	M8	M6	M8	-	M8	M10	M8	M10	-	M12	M16	M12	M16
Internal threaded anchor FIS E	-	-	-	-	M6	M8	-	-	-	M10	M12	-	-	-
					11x85					15x85				
Perforated sleeve FIS H K	12x50		12x85		16x85			16x130		20x85			20x130	

**Shear load  $V_{RK}$  [kN] depending on the compressive strength  $f_b$  (temperature range 50/80°C and 72/120°C)**

compressive strength $f_b$	use category									
	w/w	w/d								
6 N/mm <sup>2</sup>	w/w	w/d	1,5	1,5	1,5	2,5	1,5	2,0		
	d/d									
8 N/mm <sup>2</sup>	w/w	w/d	2,0	2,0	2,0	3,5	2,0	3,0		
	d/d									
10 N/mm <sup>2</sup>	w/w	w/d	2,5	3,0	3,0	4,5	3,0	3,5		
	d/d									

**Table C70.2:** Characteristic resistance under shear load (Push through anchorage)

Anchor rod	M10	M12	M16
Perforated sleeve FIS H K	18x130/200		22x130/200

**Shear load  $V_{RK}$  [kN] depending on the compressive strength  $f_b$  (temperature range 50/80°C and 72/120°C)**

compressive strength $f_b$	use category			
	w/w	w/d		
6 N/mm <sup>2</sup>	w/w	w/d	2,0	
	d/d			
8 N/mm <sup>2</sup>	w/w	w/d	3,0	
	d/d			
10 N/mm <sup>2</sup>	w/w	w/d	3,5	
	d/d			

Factor for job site tests and displacements see annex C110.

fischer injektion system FIS V masonry

**Performances**

Vertical perforated brick HLz, Characteristic resistance under shear load

**Annex C 70**

**Vertical perforated brick HLz, EN 771-1**

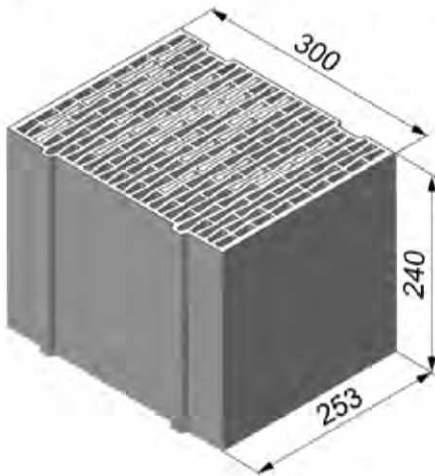

Vertical perforated brick HLz, EN 771-1			
Producer	e.g. Ziegelwerk Brenna		
Nominal dimensions [mm]	length L	width W	height H
	253	300	240
Density $\rho$ [kg/dm <sup>3</sup> ]	≥ 0,8		
Compressive strength $f_b$ [N/mm <sup>2</sup> ]	2 / 4 / 6		
Standard or annex	EN 771-1		

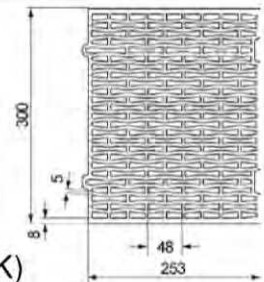

**Table C71.1:** Installation parameters  
(Pre-positioned anchorage with perforated sleeve FIS HK)

<b>Anchor rod</b>	M6	M8	M6	M8	-	M8	M10	M8	M10	-	M12	M16	M12	M16
<b>Internal threaded anchor FIS E</b>	-	-	M6	M8	11x85	-	-	-	M10	M12	15x85	-	-	-
<b>Perforated sleeve FIS H K</b>	12x50	12x85	16x85		16x130		20x85		20x130					
<b>Anchor rod and internal threaded anchor FIS E with perforated sleeve FIS H K</b>														
Max. installation torque $T_{inst,max}$ [Nm]	2													
<b>General installation parameters</b>														
Edge distance $c_{min}$	60													
Spacing $s_{min}$	$s_{min} \parallel = s_{cr} \parallel$													
	$s_{min} \perp = s_{cr} \perp$													
<b>Drilling method</b>														
Hammer drilling with hard metal hammer drill														

**Table C71.2:** Group factors

<b>Anchor rod</b>	M6	M8	M6	M8	-	M8	M10	M8	M10	-	M12	M16	M12	M16
<b>Internal threaded anchor FIS E</b>	-	-	M6	M8	11x85	-	-	-	M10	M12	15x85	-	-	-
<b>Perforated sleeve FIS H K</b>	12x50	12x85	16x85		16x130		20x85		20x130					
Group factors	$\alpha_{q,N} \parallel$	2												
	$\alpha_{q,V} \parallel$													
	$\alpha_{q,N} \perp$													
	$\alpha_{q,V} \perp$													

fischer injektion system FIS V masonry

**Performances**  
Vertical perforated brick HLz, dimensions, installation parameters

**Annex C 71**

<b>Vertical perforated brick HLz, EN 771-1</b>			
<b>Table C72.1:</b> Installation parameters (Push through anchorage with perforated sleeve FIS HK)			
<b>Anchor rod</b>	<b>M10</b>	<b>M12</b>	<b>M16</b>
<b>Perforated sleeve FIS H K</b>	<b>18x130/200</b>		<b>22x130/200</b>
<b>Anchor rod with perforated sleeve FIS H K</b>			
Max. installation torque	$T_{inst,max}$ [Nm]	2	
<b>General installation parameters</b>			
Edge distance	$c_{min}$	60	
Spacing	$s_{min \parallel} = s_{cr \parallel}$	255	
	$s_{min \perp} = s_{cr \perp}$	240	
<b>Drilling method</b>			
Hammer drilling with hard metal hammer drill			
<b>Table C72.2:</b> Group factors			
<b>Anchor rod</b>	<b>M10</b>	<b>M12</b>	<b>M16</b>
<b>Perforated sleeve FIS H K</b>	<b>18x130/200</b>		<b>22x130/200</b>
Group factors	$\alpha_{q,N \parallel}$	[-]	2
	$\alpha_{q,V \parallel}$		
	$\alpha_{q,N \perp}$		
	$\alpha_{q,V \perp}$		
fischer injektion system FIS V masonry			<b>Annex C 72</b>
<b>Performances</b> Vertical perforated brick HLz, dimensions, installation parameters			

**Vertical perforated brick HLz, EN 771-1****Table C73.1:** Characteristic resistance under tensile load (Pre-positioned anchorage)

Anchor rod	M6	M8	M6	M8	-	M8	M10	M8	M10	-	M12	M16	M12	M16
Internal threaded anchor FIS E	-	-	-	-	M6	M8	-	-	-	M10	M12	-	-	-
					11x85					15x85				
Perforated sleeve FIS H K	12x50		12x85		16x85			16x130		20x85			20x130	
<b>Tensile load <math>N_{Rk}</math> [kN] depending on the compressive strength <math>f_b</math> (temperature range 50/80°C)</b>														
compressive strength $f_b$	use category													
2 N/mm <sup>2</sup>	w/w	w/d	-	0,5	0,5			0,4		0,5			0,4	
	d/d		0,3	0,5	0,5			0,5		0,5			0,5	
4 N/mm <sup>2</sup>	w/w	w/d	0,5	0,9	0,9			0,9		0,9			0,9	
	d/d		0,6	0,9	0,9			0,9		0,9			0,9	
6 N/mm <sup>2</sup>	w/w	w/d	0,75	1,5	1,5			1,2		1,5			1,2	
	d/d		0,9	1,5	1,5			1,5		1,5			1,5	

**Table C73.2:** Characteristic resistance under tensile load (Push through anchorage)

Anchor rod	M10		M12		M16	
Perforated sleeve FIS H K	18x130/200				22x130/200	
<b>Tensile load <math>N_{Rk}</math> [kN] depending on the compressive strength <math>f_b</math> (temperature range 50/80°C)</b>						
compressive strength $f_b$	use category					
2 N/mm <sup>2</sup>	w/w	w/d	0,4			
	d/d		0,5			
4 N/mm <sup>2</sup>	w/w	w/d	0,9			
	d/d		0,9			
6 N/mm <sup>2</sup>	w/w	w/d	1,2			
	d/d		1,5			

Factor for job site tests and displacements see annex C110.

Factor for temperature range 72/120°C: 0,83

fischer injektion system FIS V masonry

**Performances**

Vertical perforated brick HLz, Characteristic resistance under tensile load

**Annex C 73**



**Vertical perforated brick HLz, EN 771-1****Table C74.1:** Characteristic resistance under shear load (Pre-positioned anchorage)

Anchor rod	M6	M8	M6	M8	-	M8	M10	M8	M10	-	M12	M16	M12	M16
Internal threaded anchor FIS E	-	-	M6	M8	11x85	-	-	-	-	M10	M12	-	-	-
Perforated sleeve FIS H K	12x50	12x85	16x85			16x130			20x85			20x130		

**Shear load  $V_{RK}$  [kN] depending on the compressive strength  $f_b$  (temperature range 50/80°C and 72/120°C)**

compressive strength $f_b$	use category			
2 N/mm <sup>2</sup>	w/w	w/d	0,5	0,6
	d/d			
4 N/mm <sup>2</sup>	w/w	w/d	0,9	1,2
	d/d			
6 N/mm <sup>2</sup>	w/w	w/d	1,5	1,5
	d/d			

**Table C74.2:** Characteristic resistance under shear load (Push through anchorage)

Anchor rod	M10	M12	M16
Perforated sleeve FIS H K	18x130/200		22x130/200

**Shear load  $V_{RK}$  [kN] depending on the compressive strength  $f_b$  (temperature range 50/80°C and 72/120°C)**

compressive strength $f_b$	use category			
2 N/mm <sup>2</sup>	w/w	w/d	0,5	0,6
	d/d			
4 N/mm <sup>2</sup>	w/w	w/d	0,9	1,2
	d/d			
6 N/mm <sup>2</sup>	w/w	w/d	1,5	1,5
	d/d			

Factor for job site tests and displacements see annex C110.

fischer injektion system FIS V masonry

**Performances**

Vertical perforated brick HLz, Characteristic resistance under shear load

**Annex C 74**

**Vertical perforated brick HLz, Porothersm W 44, filled with mineral wool, EN 771-1**

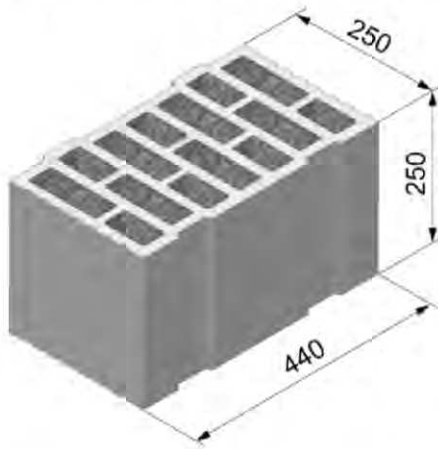

Vertical perforated brick HLz, Porothersm W 44, filled with mineral wool, EN 771-1			
Producer	-		
Nominal dimensions [mm]	length L	width W	height H
	250	440	250
Density $\rho$ [kg/dm <sup>3</sup> ]	0,7		
Compressive strength $f_b$ [N/mm <sup>2</sup> ]	6 / 8 / 10		
Standard or annex	EN 771-1		

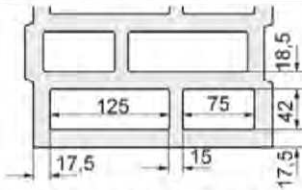

**Table C75.1:** Installation parameters (Pre-positioned anchorage with perforated sleeve FIS HK)

<b>Anchor rod</b>	M6	M8	M6	M8	-	M8	M10	M8	M10	-	M12	M16	M12	M16	M12	M16
<b>Internal threaded anchor FIS E</b>	-	-	M6	M8	11x85	-	-	M10	M12	15x85	-	-	-	-	-	-
<b>Perforated sleeve FIS H K</b>	12x50		12x85		16x85			16x130			20x85		20x130		20x200	
<b>Anchor rod and internal threaded anchor FIS E with perforated sleeve FIS H K</b>																
Max. installation torque $T_{inst,max}$ [Nm]	2					5	2	5	6							
<b>General installation parameters</b>																
Edge distance $c_{min}$	60															
Spacing	$s_{min} \parallel$	80														
	$s_{cr} \parallel$	250														
	$s_{min} \perp$	80														
	$s_{cr} \perp$	250														
<b>Drilling method</b>																
Rotary drilling with carbide drill																

**Table C75.2:** Group factors

<b>Anchor rod</b>	M6	M8	M6	M8	-	M8	M10	M8	M10	-	M12	M16	M12	M16	M12	M16
<b>Internal threaded anchor FIS E</b>	-	-	M6	M8	11x85	-	-	M10	M12	15x85	-	-	-	-	-	-
<b>Perforated sleeve FIS H K</b>	12x50		12x85		16x85			16x130			20x85		20x130		20x200	
Group factors	$\alpha_{q,N} \parallel$	1,3														
	$\alpha_{q,V} \parallel$	1,3														
	$\alpha_{q,N} \perp$	0,8														
	$\alpha_{q,V} \perp$	1,3														

fischer injektion system FIS V masonry

**Performances**

Vertical perforated brick HLz, Porothersm W 44, filled with mineral wool; dimensions, installation parameters

**Annex C 75**

**Vertical perforated brick HLz, Porothersm W 44, filled with mineral wool, EN 771-1****Table C76.1:** Installation parameters  
(Push through anchorage with perforated sleeve FIS HK)

Anchor rod		M10	M12	M16
Perforated sleeve FIS H K		18x130/200		22x130/200
<b>Anchor rod with perforated sleeve FIS H K</b>				
Max. installation torque	$T_{inst,max}$ [Nm]	5	6	
<b>General installation parameters</b>				
Edge distance	$c_{min}$			60
Spacing	$s_{min} \parallel$			80
	$s_{cr} \parallel$			250
	$s_{min} \perp$			80
	$s_{cr} \perp$			250
<b>Drilling method</b>				
Rotary drilling with carbide drill				

**Table C76.2:** Group factors

Anchor rod		M10	M12	M16
Perforated sleeve FIS H K		18x130/200		22x130/200
Group factors	$\alpha_{a,N} \parallel$			1,3
	$\alpha_{a,V} \parallel$			1,3
	$\alpha_{a,N} \perp$			0,8
	$\alpha_{a,V} \perp$			1,3

fischer injektion system FIS V masonry

**Performances**Vertical perforated brick HLz, Porothersm W 44, filled with mineral wool;  
dimensions, installation parameters**Annex C 76**

<b>Vertical perforated brick HLz, Porothersm W 44, filled with mineral wool, EN 771-1</b>																			
<b>Table C77.1: Characteristic resistance under tensile load (Pre-positioned anchorage)</b>																			
Anchor rod		M6	M8	M6	M8	-		M8	M10	M8	M10	-		M12	M16	M12	M16	M12	M16
Internal threaded anchor FIS E		-		-		M6	M8	-		-		M10	M12	-				-	
Perforated sleeve FIS H K		12x50		12x85		16x85			16x130			20x85			20x130		20x200		
<b>Tensile load <math>N_{Rk}</math> [kN] depending on the compressive strength <math>f_b</math> (temperature range 50/80°C)</b>																			
compressive strength $f_b$		use category																	
<b>6 N/mm<sup>2</sup></b>	w/w	w/d	0,75	1,5	1,2						1,5					2,5			
	d/d		0,9	1,5	1,2						1,5					2,5			
<b>8 N/mm<sup>2</sup></b>	w/w	w/d	0,9	1,5	1,2						1,5					2,5			
	d/d		0,9	2,0	1,5						2,0					3,0			
<b>10 N/mm<sup>2</sup></b>	w/w	w/d	0,9	2,0	1,5						2,0					3,0			
	d/d		1,2	2,0	1,5						2,0					3,5			
<b>Table C77.2: Characteristic resistance under tensile load (Push through anchorage)</b>																			
Anchor rod		M10				M12				M16									
Perforated sleeve FIS H K		18x130/200								22x130/200									
<b>Tensile load <math>N_{Rk}</math> [kN] depending on the compressive strength <math>f_b</math> (temperature range 50/80°C)</b>																			
compressive strength $f_b$		use category																	
<b>6 N/mm<sup>2</sup></b>	w/w	w/d													1,5				
	d/d														1,5				
<b>8 N/mm<sup>2</sup></b>	w/w	w/d													1,5				
	d/d														2,0				
<b>10 N/mm<sup>2</sup></b>	w/w	w/d													2,0				
	d/d														2,0				
Factor for job site tests and displacements see annex C110																			
Factor for temperature range 72/120°C: 0,83																			
fischer injektion system FIS V masonry														<b>Annex C 77</b>					
<b>Performances</b> Vertical perforated brick HLz, Porothersm W 44, filled with mineral wool, Characteristic resistance under tensile load																			

<b>Vertical perforated brick HLz, Porothersm W 44, filled with mineral wool, EN 771-1</b>																
<b>Table C78.1: Characteristic resistance under shear load (Pre-positioned anchorage)</b>																
Anchor rod	M6	M8	M6	M8	-	M8	M10	M8	M10	-	M12	M16	M12	M16	M12	M16
Internal threaded anchor FIS E	-		-		M6	M8	-		-		M10	M12	-		-	
					11x85						15x85					
Perforated sleeve FIS H K	12x50		12x85		16x85			16x130		20x85			20x130		20x200	
Shear load $V_{RK}$ [kN] depending on the compressive strength $f_b$ (temperature range 50/80°C and 72/120°C)																
compressive strength $f_b$	use category															
	w/w	w/d	0,9				1,2		0,9			1,2		1,2		
6 N/mm <sup>2</sup>	w/w	w/d	0,9				1,5		0,9			1,5		1,2		
	d/d	d/d	1,2				1,5		1,2			1,5		1,5		
8 N/mm <sup>2</sup>	w/w	w/d	1,2				1,5		1,2			1,5		1,5		
	d/d	d/d														
10 N/mm <sup>2</sup>	w/w	w/d														
	d/d	d/d														
<b>Table C78.2: Characteristic resistance under shear load (Push through anchorage)</b>																
Anchor rod	M10				M12				M16							
Perforated sleeve FIS H K	18x130/200								22x130/200							
Shear load $V_{RK}$ [kN] depending on the compressive strength $f_b$ (temperature range 50/80°C and 72/120°C)																
compressive strength $f_b$	use category															
	w/w	w/d	1,2				1,2									
6 N/mm <sup>2</sup>	w/w	w/d	1,5				1,5									
	d/d	d/d	1,5				1,5									
8 N/mm <sup>2</sup>	w/w	w/d	1,5				1,5									
	d/d	d/d														
10 N/mm <sup>2</sup>	w/w	w/d														
	d/d	d/d														
Factor for job site tests and displacements see annex C110.																
fischer injektion system FIS V masonry														<b>Annex C 78</b>		
<b>Performances</b> Vertical perforated brick HLz, Porothersm W 44, filled with mineral wool; Characteristic resistance under shear load																

**Vertical perforated brick HLz, EN 771-1**

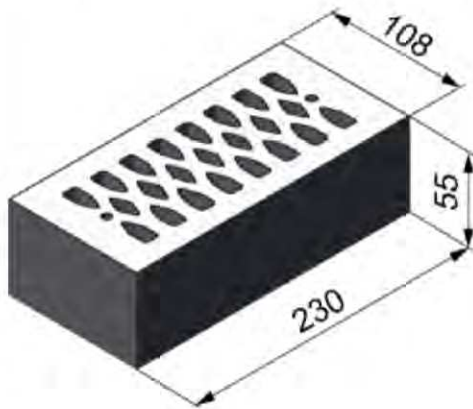

Vertical perforated brick HLz, EN 771-1			
Producer	e.g. Wienerberger.		
Nominal dimensions [mm]	length L	width W	height H
	230	108	55
Density $\rho$ [kg/dm <sup>3</sup> ]	≥ 1,4		
Compressive strength $f_b$ [N/mm <sup>2</sup> ]	2 / 4 / 6 / 8		
Standard or annex	EN 771-1		

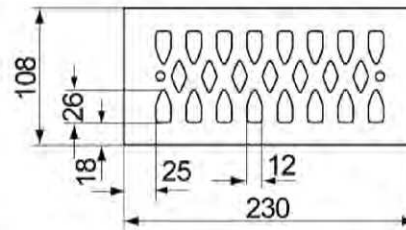

**Table C79.1:** Installation parameters

<b>Anchor rod</b>	M6	M8	M6	M8	-	M8	M10	-	M12	M16		
<b>Internal threaded anchor FIS E</b>	-		-		M6	M8	-		M10	M12		
	-		-		11x85		-		15x85			
<b>Perforated sleeve FIS H K</b>	12x50		12x85		16x85			20x85				
<b>Anchor rod and internal threaded anchor FIS E with perforated sleeve FIS H K</b>												
Max. installation torque $T_{inst,max}$ [Nm]	2											
<b>General installation parameters</b>												
Edge distance $c_{min}$	60											
Spacing	$s_{min}$	$s_{cr}$	[mm]	80							-	
				230							-	
				60							-	
				60							-	
				60							-	
<b>Drilling method</b>												
Hammer drilling with hard metal hammer drill												

**Table C79.2:** Group factors

<b>Anchor rod</b>	M6	M8	M6	M8	-	M8	M10	-	M12	M16		
<b>Internal threaded anchor FIS E</b>	-		-		M6	M8	-		M10	M12		
	-		-		11x85		-		15x85			
<b>Perforated sleeve FIS H K</b>	12x50		12x85		16x85			20x85				
Group factors	$\alpha_{q,N}$	$\alpha_{q,V}$	[-]	2							-	
				2							-	
				2							-	
				2							-	

fischer injektion system FIS V masonry

**Performances**

Vertical perforated brick HLz, dimensions, installation parameters

**Annex C 79**

**Vertical perforated brick HLz, EN 771-1**

**Table C80.1:** Characteristic resistance under tensile load <sup>1)</sup>

Anchor rod		M6	M8	M6	M8	-	M8	M10	-	M12	M16	
Internal threaded anchor FIS E		-		-		M6	M8	-		M10	M12	-
						11x85				15x85		
Perforated sleeve FIS H K		12x50		12x85		16x85			20x85			
<b>Tensile load <math>N_{Rk}</math> [kN] depending on the compressive strength <math>f_b</math> (temperature range 50/80°C)</b>												
compressive strength $f_b$	use category											
2 N/mm <sup>2</sup>	w/w	w/d	0,3	0,9	0,75			0,5				
	d/d		0,3	0,9	0,9			0,6				
4 N/mm <sup>2</sup>	w/w	w/d	0,6	1,5	1,5			0,9				
	d/d		0,75	2,0	1,5			1,2				
6 N/mm <sup>2</sup>	w/w	w/d	0,9	2,5	2,5			1,5				
	d/d		0,9	3,0	2,5			1,5				
8 N/mm <sup>2</sup>	w/w	w/d	1,2	3,5	3,0			2,0				
	d/d		1,5	4,0	3,5			2,5				

<sup>1)</sup> If the fixing is in a solid area, for w/w, the characteristic value shall be reduced with the factor 0,64.

Factor for temperature range 72/120°C: 0,83

**Table C80.2:** Characteristic resistance under shear load

Anchor rod		M6	M8	M6	M8	-	M8	M10	-	M12	M16	
Internal threaded anchor FIS E		-		-		M6	M8	-		M10	M12	-
						11x85				15x85		
Perforated sleeve FIS H K		12x50		12x85		16x85			20x85			
<b>Shear load <math>V_{Rk}</math> [kN] depending on the compressive strength <math>f_b</math> (temperature range 50/80°C and 72/120°C)</b>												
compressive strength $f_b$	use category											
2 N/mm <sup>2</sup>	w/w	w/d	0,6						0,4			
	d/d		0,6						0,4			
4 N/mm <sup>2</sup>	w/w	w/d	1,2						0,9			
	d/d		1,2						0,9			
6 N/mm <sup>2</sup>	w/w	w/d	1,5						1,2			
	d/d		1,5						1,2			
8 N/mm <sup>2</sup>	w/w	w/d	2,5						1,5			
	d/d		2,5						1,5			

Factor for job site tests and displacements see annex C110

fischer injektion system FIS V masonry

**Performances**

Vertical perforated brick HLz, Characteristic resistance under tensile and shear load

**Annex C 80**

**Horizontal perforated brick LLz, EN 771-1**

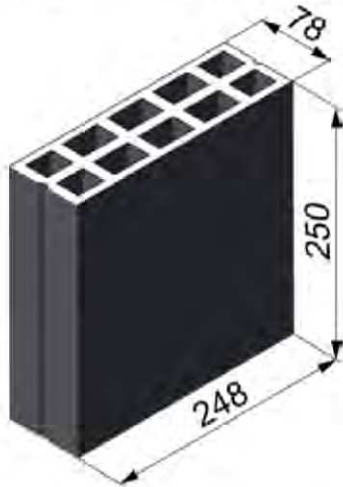

Horizontal perforated brick LLz, EN 771-1			
Producer	-		
Nominal dimensions [mm]	length L	width W	height H
	250	78	248
Density $\rho$ [kg/dm <sup>3</sup> ]	≥ 0,7		
Compressive strength $f_b$ [N/mm <sup>2</sup> ]	2 / 4 / 6		
Standard or annex	EN 771-1		

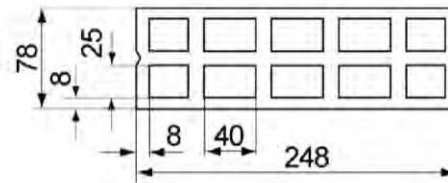

**Table C81.1:** Installation parameters

Anchor rod		M6	M8
Perforated sleeve FIS H K		12x50	
<b>Anchor rod with perforated sleeve FIS H K</b>			
Max. installation torque	$T_{inst,max}$ [Nm]	2	
<b>General installation parameters</b>			
Edge distance	$c_{min}$	100	
Spacing	$s_{min} \parallel$	75	
	$s_{cr} \parallel$	250	
	$s_{min} \perp = s_{cr} \perp$	250	
<b>Drilling method</b>			
Hammer drilling with hard metal hammer drill			

**Table C81.2:** Group factors

Anchor rod		M6	M8
Perforated sleeve FIS H K		12x50	
Group factors	$\alpha_{q,N} \parallel$	1,6	
	$\alpha_{q,V} \parallel$	1,1	
	$\alpha_{q,N} \perp$	2,0	
	$\alpha_{q,V} \perp$	2,0	

fischer injektion system FIS V masonry

**Performances**  
Horizontal perforated brick LLz, dimensions, installation parameters

**Annex C 81**



**Horizontal perforated brick LLz, EN 771-1****Table C82.1:** Characteristic resistance under tensile load

Anchor rod		M6		M8	
Perforated sleeve FIS H K		12x50			
Tensile load $N_{Rk}$ [kN] depending on the compressive strength $f_b$ (temperature range 50/80°C)					
compressive strength $f_b$	use category				
2 N/mm <sup>2</sup>	w/w	w/d	0,5		
	d/d		0,6		
4 N/mm <sup>2</sup>	w/w	w/d	0,9		
	d/d		1,2		
6 N/mm <sup>2</sup>	w/w	w/d	1,5		
	d/d		1,5		

Factor for temperature range 72/120°C: 0,83

**Table C82.2:** Characteristic resistance under shear load

Anchor rod		M6		M8	
Perforated sleeve FIS H K		12x50			
Shear load $V_{Rk}$ [kN] depending on the compressive strength $f_b$ (temperature range 50/80°C and 72/120°C)					
compressive strength $f_b$	use category				
2 N/mm <sup>2</sup>	w/w	w/d	0,5		
	d/d		0,5		
4 N/mm <sup>2</sup>	w/w	w/d	0,9		
	d/d		0,9		
6 N/mm <sup>2</sup>	w/w	w/d	1,5		
	d/d		1,5		

Factor for job site tests and displacements see annex C110.

fischer injektion system FIS V masonry

**Performances**

Horizontal perforated brick LLz, Characteristic resistance under tensile and shear load

**Annex C 82**

**Horizontal perforated brick LLz, EN 771-1**



Horizontal perforated brick LLz, EN 771-1			
Producer	e.g. Ceramica Farreny S.A.		
Nominal dimensions [mm]	length L	width W	height H
	275	88	128
Density $\rho$ [kg/dm <sup>3</sup> ]	≥ 0,8		
Compressive strength $f_b$ [N/mm <sup>2</sup> ]	2		
Standard or annex	EN 771-1		

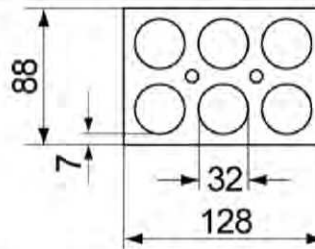

**Table C83.1:** Installation parameters

Anchor rod		M6	M8
Perforated sleeve FIS H K		12x50	
<b>Anchor rod with perforated sleeve FIS H K</b>			
Max. installation torque	$T_{inst,max}$ [Nm]	2	
<b>General installation parameters</b>			
Edge distance	$c_{min}$	60	
	$s_{min} \parallel$	75	
	$s_{cr} \parallel$ [mm]	275	
	$s_{min} \perp$	75	
	$s_{cr} \perp$	130	
<b>Drilling method</b>			
Hammer drilling with hard metal hammer drill			

**Table C83.2:** Group factors

Anchor rod		M6	M8
Perforated sleeve FIS H K		12x50	
Group factors	$\alpha_{q,N} \parallel$	1,3	
	$\alpha_{q,V} \parallel$	1,5	
	$\alpha_{q,N} \perp$	1,3	
	$\alpha_{q,V} \perp$	1,5	

fischer injektion system FIS V masonry

**Performances**  
Horizontal perforated brick LLz, dimensions, installation parameters

**Annex C 83**

<b>Horizontal perforated brick LLz, EN 771-1</b>			
<b>Table C84.1: Characteristic resistance under tensile load</b>			
Anchor rod		M6	M8
Perforated sleeve FIS H K		12x50	
<b>Tensile load <math>N_{Rk}</math> [kN] depending on the compressive strength <math>f_b</math> (temperature range 50/80°C)</b>			
compressive strength $f_b$	use category		
2 N/mm <sup>2</sup>	w/w	w/d	1,5
	d/d		
Factor for temperature range 72/120°C: 0,83			
<b>Table C84.2: Characteristic resistance under shear load</b>			
Anchor rod		M6	M8
Perforated sleeve FIS H K		12x50	
<b>Shear load <math>V_{Rk}</math> [kN] depending on the compressive strength <math>f_b</math> (temperature range 50/80°C and 72/120°C)</b>			
compressive strength $f_b$	use category		
2 N/mm <sup>2</sup>	w/w	w/d	1,2
	d/d		
Factor for job site tests and displacements see annex C110			
fischer injektion system FIS V masonry			<b>Annex C 84</b>
<b>Performances</b> Horizontal perforated brick LLz, Characteristic resistance under tensile and shear load			

**Light-weight concrete hollow block Hbl, EN 771-3**

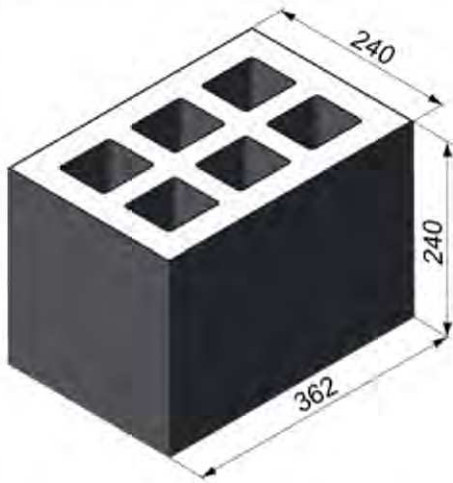

Light-weight concrete hollow block Hbl, EN 771-3			
Producer	-		
Nominal dimensions [mm]	Länge L	Breite B	Höhe H
	362	240	240
Density $\rho$ [kg/dm <sup>3</sup> ]	≥ 1,0		
Compressive strength $f_b$ [N/mm <sup>2</sup> ]	2 / 4		
Standard or annex	EN 771-3		

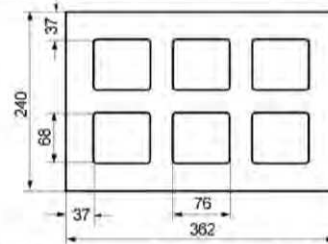

**Table C85.1:** Installation parameters  
(Pre-positioned anchorage with perforated sleeve FIS HK)

<b>Anchor rod</b>	M6	M8	M6	M8	-	M8	M10	M8	M10	-	M12	M16	M12	M16	M12	M16
<b>Internal threaded anchor FIS E</b>	-	-	M6 M8		11x85		-	-	M10/M12		15x85		-	-	-	-
<b>Perforated sleeve FIS H K</b>	12x50		12x85		16x85			16x130		20x85			20x130		20x200	
<b>Anchor rod and internal threaded anchor FIS E with perforated sleeve FIS H K</b>																
Max. installation torque $T_{inst,max}$ [Nm]	2															
<b>General installation parameters</b>																
Edge distance $c_{min}$	60															
Spacing	$s_{min \parallel}$	100														
	$s_{cr \parallel}$	362														
	$s_{min \perp} = s_{cr \perp}$	240														
<b>Drilling method</b>																
Hammer drilling with hard metal hammer drill																

**Table C85.2:** Group factors

<b>Anchor rod</b>	M6	M8	M6	M8	-	M8	M10	M8	M10	-	M12	M16	M12	M16	M12	M16
<b>Internal threaded anchor FIS E</b>	-	-	M6 M8		11x85		-	-	M10/M12		15x85		-	-	-	-
<b>Perforated sleeve FIS H K</b>	12x50		12x85		16x85			16x130		20x85			20x130		20x200	
Group factors	$\alpha_{q,N \parallel}$	1,2														
	$\alpha_{q,V \parallel}$	1,1														
	$\alpha_{q,N \perp}$	2,0														
	$\alpha_{q,V \perp}$	2,0														

fischer injektion system FIS V masonry

**Performances**  
Light-weight concrete hollow block Hbl, dimensions, installation parameters

**Annex C 85**

**Light-weight concrete hollow block Hbl, EN 771-3****Table C86.1:** Installation parameters  
(Push through anchorage with perforated sleeve FIS HK)

Anchor rod		M10	M12	M16
Perforated sleeve FIS H K		18x130/200		22x130/200
<b>Anchor rod with perforated sleeve FIS H K</b>				
Max. installation torque	$T_{inst,max}$ [Nm]	2		
<b>General installation parameters</b>				
Edge distance	$c_{min}$	60		
Spacing	$s_{min \parallel}$	100		
	$s_{cr \parallel}$	362		
	$s_{min \perp} = s_{cr \perp}$	240		
<b>Drilling method</b>				
Hammer drilling with hard metal hammer drill				

**Table C86.2:** Group factors

Anchor rod		M10	M12	M16
Perforated sleeve FIS H K		18x130/200		22x130/200
Group factors	$\alpha_{q,N \parallel}$	1,2		
	$\alpha_{q,V \parallel}$	1,1		
	$\alpha_{q,N \perp}$	2,0		
	$\alpha_{q,V \perp}$			

fischer injektion system FIS V masonry

**Performances**  
Light-weight concrete hollow block Hbl, dimensions, installation parameters**Annex C 86**

**Light-weight concrete hollow block Hbl, EN 771-3**

**Table C87.1:** Characteristic resistance under tensile load (Pre-positioned anchorage)

Anchor rod	M6	M8	M6	M8	-	M8	M10	M8	M10	-	M12	M16	M12	M16	M12	M16	
Internal threaded anchor FIS E	-	-	-	-	M6 11x85	M8	M10	-	-	M10 15x85	M12	M16	M12	M16	M12	M16	
Perforated sleeve FIS H K	12x50		12x85		16x85			16x130			20x85		20x130		20x200		
Tensile load $N_{Rk}$ [kN] depending on the compressive strength $f_b$ (temperature range 50/80°C)																	
compressive strength $f_b$	use category																
2 N/mm <sup>2</sup>	w/w	w/d	1,2								1,5						2,5
	d/d		1,2								1,5						2,5
4 N/mm <sup>2</sup>	w/w	w/d	2,0								3,0						5,0
	d/d		2,5								3,0						5,5

**Table C87.2:** Characteristic resistance under tensile load (Push through anchorage)

Anchor rod	M10		M12		M16	
Perforated sleeve FIS H K	18x130/200				22x130/200	
Tensile load $N_{Rk}$ [kN] depending on the compressive strength $f_b$ (temperature range 50/80°C)						
compressive strength $f_b$	use category					
2 N/mm <sup>2</sup>	w/w	w/d	1,5			
	d/d		1,5			
4 N/mm <sup>2</sup>	w/w	w/d	3,0			
	d/d		3,0			

Factor for job site tests and displacements see annex C110

Factor for temperature range 72/120°C: 0,83

fischer injektion system FIS V masonry

**Performances**

Light-weight concrete hollow block Hbl, Characteristic resistance under tensile load

**Annex C 87**

**Light-weight concrete hollow block Hbl, EN 771-3**

**Table C88.1:** Characteristic resistance under shear load (Pre-positioned anchorage)

<b>Anchor rod</b>	M6	M8	M6	M8	-	M8	M10	M8	M10	-	M12	M16	M12	M16	M12	M16
<b>Internal threaded anchor FIS E</b>	-		-		M6	M8	-		-		M10	M12	-		-	
					11x85						15x85					
<b>Perforated sleeve FIS H K</b>	12x50		12x85		16x85			16x130		20x85			20x130		20x200	
<b>Shear load <math>V_{Rk}</math> [kN] depending on the compressive strength <math>f_b</math> (temperature range 50/80°C and 72/120°C)</b>																
compressive strength $f_b$	use category															
<b>2 N/mm<sup>2</sup></b>	w/w	w/d	0,9													
	d/d															
<b>4 N/mm<sup>2</sup></b>	w/w	w/d	2,0													
	d/d															

**Table C88.2:** Characteristic resistance under shear load (Push through anchorage)

<b>Anchor rod</b>	<b>M10</b>			<b>M12</b>			<b>M16</b>		
<b>Perforated sleeve FIS H K</b>	<b>18x130/200</b>						<b>22x130/200</b>		
<b>Shear load <math>V_{Rk}</math> [kN] depending on the compressive strength <math>f_b</math> (temperature range 50/80°C and 72/120°C)</b>									
compressive strength $f_b$	use category								
<b>2 N/mm<sup>2</sup></b>	w/w	w/d	0,9						
	d/d								
<b>4 N/mm<sup>2</sup></b>	w/w	w/d	2,0						
	d/d								

Factor for job site tests and displacements see annex C110

fischer injektion system FIS V masonry

**Performances**

Light-weight concrete hollow block Hbl, Characteristic resistance under shear load

**Annex C 88**

**Light-weight concrete hollow block Hbl, EN 771-3**

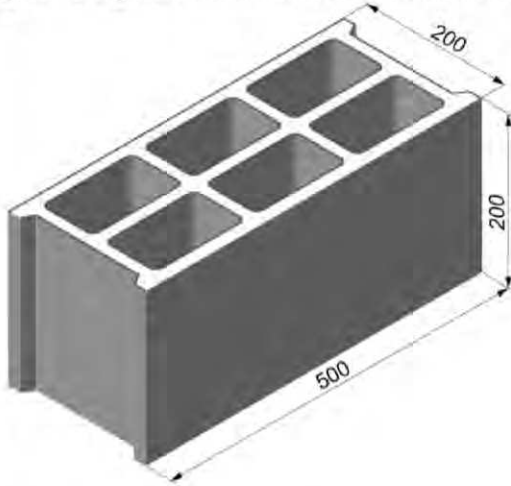

Light-weight concrete hollow block Hbl, EN 771-3			
Producer	e.g. Sepa		
Nominal dimensions [mm]	length L	width W	height H
	500	200	200
Density $\rho$ [kg/dm <sup>3</sup> ]	≥ 1,0		
Compressive strength $f_b$ [N/mm <sup>2</sup> ]	2 / 4 / 6		
Standard or annex	EN 771-1		

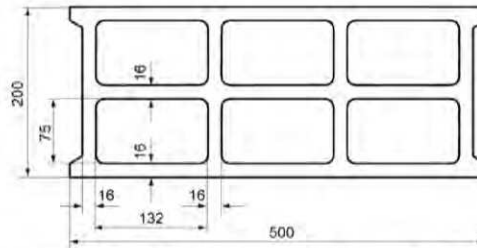

**Table C89.1:** Installation parameters

<b>Anchor rod</b>	M6	M8	M6	M8	-	M8	M10	M8	M10	M10	M12	-	M12	M16
<b>Internal threaded anchor FIS E</b>	-	-	M6	M8	11x85	-	-	-	-	-	-	M10	M12	-
<b>Perforated sleeve FIS H K</b>	12x50		12x85		16x85			16x130		18x130/200		20x85		
<b>Anchor rod and internal threaded anchor FIS E with perforated sleeve FIS H K</b>														
Max. installation torque $T_{inst,max}$ [Nm]	1				2									
<b>General installation parameters</b>														
Edge distance $c_{min}$					100									
Spacing $s_{min}$    = $s_{cr}$    [mm]					500									
					200									
<b>Drilling method</b>														
Hammer drilling with hard metal hammer drill														

**Table C89.2:** Group factors

<b>Anchor rod</b>	M6	M8	M6	M8	-	M8	M10	M8	M10	M10	M12	-	M12	M16	
<b>Internal threaded anchor FIS E</b>	-	-	M6	M8	11x85	-	-	-	-	-	-	M10	M12	-	
<b>Perforated sleeve FIS H K</b>	12x50		12x85		16x85			16x130		18x130/200		20x85			
Group factors [-]	$\alpha_{q,N}$					2									
	$\alpha_{q,V}$														
	$\alpha_{q,N}$ ⊥														
	$\alpha_{q,V}$ ⊥														

fischer injektion system FIS V masonry

**Performances**  
Light-weight concrete hollow block Hbl, dimensions, installation parameters

**Annex C 89**



**Light-weight concrete hollow block Hbl, EN 771-3****Table C90.1:** Characteristic resistance under tensile load

Anchor rod	M6	M8	M6	M8	-	M8	M10	M8	M10	M10	M12	-	M12	M16
Internal threaded anchor FIS E	-	-	M6	M8	11x85	-	-	-	-	-	-	M10	M12	-
Perforated sleeve FIS H K	12x50	12x85	16x85			16x130		18x130/200		20x85				
<b>Tensile load <math>N_{Rk}</math> [kN] depending on the compressive strength <math>f_b</math> (temperature range 50/80°C)</b>														
compressive strength $f_b$	use category													
2 N/mm <sup>2</sup>	w/w	w/d	0,4											
	d/d		0,5											
4 N/mm <sup>2</sup>	w/w	w/d	0,9											
	d/d		0,9											
6 N/mm <sup>2</sup>	w/w	w/d	1,2											
	d/d		1,5											

Factor for temperature range 72/120°C: 0,83

**Table C90.2:** Characteristic resistance under shear load

Anchor rod	M6	M8	M6	M8	-	M8	M10	M8	M10	M10	M12	-	M12	M16
Internal threaded anchor FIS E	-	-	M6	M8	11x85	-	-	-	-	-	-	M10	M12	-
Perforated sleeve FIS H K	12x50	12x85	16x85			16x130		18x130/200		20x85				
<b>Shear load <math>V_{Rk}</math> [kN] depending on the compressive strength <math>f_b</math> (temperature range 50/80°C and 72/120°C)</b>														
compressive strength $f_b$	use category													
2 N/mm <sup>2</sup>	w/w	w/d	0,9											
	d/d		0,9											
4 N/mm <sup>2</sup>	w/w	w/d	1,5											
	d/d		1,5											
6 N/mm <sup>2</sup>	w/w	w/d	2,5											
	d/d		2,5											

Factor for job site tests and displacements see annex C110

fischer injektion system FIS V masonry

**Performances**Light-weight concrete hollow block Hbl,  
Characteristic resistance under tensile and shear load**Annex C 90**

**Light-weight concrete hollow block Hbl, EN 771-3**

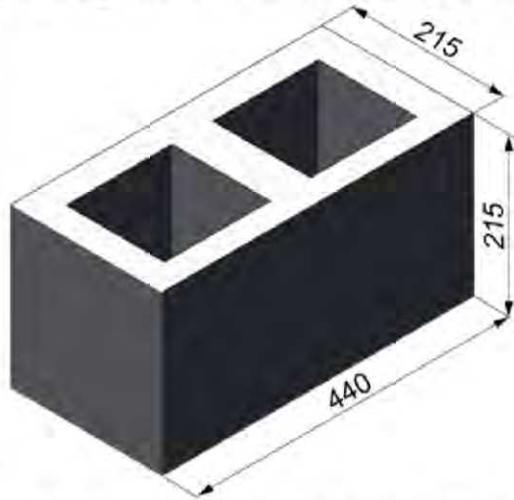

Light-weight concrete hollow block Hbl, EN 771-3			
Producer	e.g. Roadstone wood		
Nominal dimensions [mm]	length L	width W	height H
	440	215	215
Density $\rho$ [kg/dm <sup>3</sup> ]	≥ 1,2		
Compressive strength $f_b$ [N/mm <sup>2</sup> ]	4 / 6 / 8 / 10		
Standard or annex	EN 771-3		

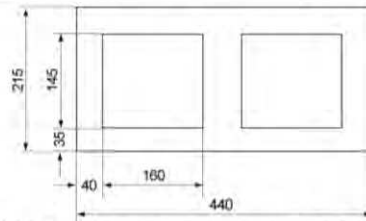

**Table C91.1:** Installation parameters (Pre-positioned anchorage with perforated sleeve FIS HK)

<b>Anchor rod</b>	M6	M8	M6	M8	-	M8	M10	M8	M10	-	M12	M16	M12	M16
<b>Internal threaded anchor FIS E</b>	-	-	M6	M8	11x85	-	-	M10	M12	15x85	-	-	-	-
<b>Perforated sleeve FIS H K</b>	12x50		12x85		16x85		16x130		20x85		20x130			
<b>Anchor rod and internal threaded anchor FIS E with perforated sleeve FIS HK</b>														
Max. installation torque	$T_{inst,max}$	[Nm]	2											
<b>General installation parameters</b>														
Edge distance	$c_{min}$		110											
Spacing	$s_{min} \parallel$	[mm]	100											
	$s_{cr} \parallel$		440											
	$s_{min} \perp$		100											
	$s_{cr} \perp$		215											
	<b>Drilling method</b>													
Hammer drilling with hard metal hammer drill														

**Table C91.2:** Group factors

<b>Anchor rod</b>	M6	M8	M6	M8	-	M8	M10	M8	M10	-	M12	M16	M12	M16
<b>Internal threaded anchor FIS E</b>	-	-	M6	M8	11x85	-	-	M10	M12	15x85	-	-	-	-
<b>Perforated sleeve FIS H K</b>	12x50		12x85		16x85		16x130		20x85		20x130			
Group factors	$\alpha_{q,N} \parallel$	[-]	1,4											
	$\alpha_{q,V} \parallel$		2,0											
	$\alpha_{q,N} \perp$		1,4											
	$\alpha_{q,V} \perp$		1,2											

fischer injektion system FIS V masonry

**Performances**

Light-weight concrete hollow block Hbl, dimensions, installation parameters

**Annex C 91**

**Light-weight concrete hollow block Hbl, EN 771-3****Table C92.1:** Installation parameters  
(Push through anchorage with perforated sleeve FIS HK)

Anchor rod		M10	M12	M16
Perforated sleeve FIS H K		18x130/200		22x130/200
<b>Anchor rod with perforated sleeve FIS H</b>				
Max. installation torque	$T_{inst,max}$ [Nm]	2		
<b>General installation parameters</b>				
Edge distance	$c_{min}$	110		
Spacing	$s_{min} \parallel$	100		
	$s_{cr} \parallel$	440		
	$s_{min} \perp$	100		
	$s_{cr} \perp$	215		
<b>Drilling method</b>				
Hammer drilling with hard metal hammer drill				

**Table C92.2:** Group factors

Anchor rod		M10	M12	M16
Perforated sleeve FIS H K		18x130/200		22x130/200
Group factors	$\alpha_{a,N} \parallel$	1,4		
	$\alpha_{a,V} \parallel$	2,0		
	$\alpha_{a,N} \perp$	1,4		
	$\alpha_{a,V} \perp$	1,2		

fischer injektion system FIS V masonry

**Performances**  
Light-weight concrete hollow block Hbl, dimensions, installation parameters**Annex C 92**

**Light-weight concrete hollow block Hbl, EN 771-3**

**Table C93.1:** Characteristic resistance under tensile load (Pre-positioned anchorage)

Anchor rod	M6	M8	M6	M8	-	M8	M10	M8	M10	-	M12	M16	M12	M16
Internal threaded anchor FIS E	-	-	M6	M8	11x85	-	-	-	-	M10	M12	-	-	-
Perforated sleeve FIS H K	12x50	12x85	16x85			16x130			20x85			20x130		
Tensile load $N_{Rk}$ [kN] depending on the compressive strength $f_b$ (temperature range 50/80°C)														
compressive strength $f_b$	use category													
4 N/mm <sup>2</sup>	w/w	w/d	0,9			1,2			2,0					
	d/d		1,2			1,5			2,0					
6 N/mm <sup>2</sup>	w/w	w/d	1,5			2,0			3,0					
	d/d		1,5			2,0			3,0					
8 N/mm <sup>2</sup>	w/w	w/d	2,0			2,5			3,5					
	d/d		2,0			3,0			4,0					
10 N/mm <sup>2</sup>	w/w	w/d	2,5			3,0			4,5					
	d/d		3,0			3,5			5,0					

**Table C93.2:** Characteristic resistance under tensile load (Push through anchorage)

Anchor rod	M10		M12		M16	
Perforated sleeve FIS H K	18x130/200				22x130/200	
Tensile load $N_{Rk}$ [kN] depending on the compressive strength $f_b$ (temperature range 50/80°C)						
compressive strength $f_b$	use category					
4 N/mm <sup>2</sup>	w/w	w/d	1,2		2,0	
	d/d		1,5		2,0	
6 N/mm <sup>2</sup>	w/w	w/d	2,0		3,0	
	d/d		2,0		3,0	
8 N/mm <sup>2</sup>	w/w	w/d	2,5		3,5	
	d/d		3,0		4,0	
10 N/mm <sup>2</sup>	w/w	w/d	3,0		4,5	
	d/d		3,5		5,0	

Factor for job site tests and displacements see annex C110

Factor for temperature range 72/120°C: 0,83

fischer injektion system FIS V masonry

**Performances**

Light-weight concrete hollow block Hbl, Characteristic resistance under tensile load

**Annex C 93**

**Light-weight concrete hollow block Hbl, EN 771-3**

**Table C94.1:** Characteristic resistance under shear load (Pre-positioned anchorage)

Anchor rod	M6	M8	M6	M8	-	M8	M10	M8	M10	-	M12	M16	M12	M16	
Internal threaded anchor FIS E	-	-	-	-	M6	M8	-	-	-	M10	M12	-	-	-	
					11x85					15x85					
Perforated sleeve FIS H K	12x50		12x85		16x85			16x130		20x85			20x130		
<b>Shear load <math>V_{RK}</math> [kN] depending on the compressive strength <math>f_b</math> (temperature range 50/80°C and 72/120°C)</b>															
compressive strength $f_b$	use category														
4 N/mm <sup>2</sup>	w/w	w/d	0,75	1,2	0,75	1,2	0,75								1,2
	d/d														
6 N/mm <sup>2</sup>	w/w	w/d	1,2	2,0	1,2	2,0	1,2								2,0
	d/d														
8 N/mm <sup>2</sup>	w/w	w/d	1,5	2,5	1,5	2,5	1,5								2,5
	d/d														
10 N/mm <sup>2</sup>	w/w	w/d	2,0	3,0	2,0	3,0	2,0								3,0
	d/d														

**Table C94.2:** Characteristic resistance under shear load (Push through anchorage)

Anchor rod	M10		M12		M16		
Perforated sleeve FIS H K	18x130/200				22x130/200		
<b>Shear load <math>V_{RK}</math> [kN] depending on the compressive strength <math>f_b</math> (temperature range 50/80°C and 72/120°C)</b>							
compressive strength $f_b$	use category						
4 N/mm <sup>2</sup>	w/w	w/d					1,2
	d/d						
6 N/mm <sup>2</sup>	w/w	w/d					2,0
	d/d						
8 N/mm <sup>2</sup>	w/w	w/d					2,5
	d/d						
10 N/mm <sup>2</sup>	w/w	w/d					3,0
	d/d						

Factor for job site tests and displacements see annex C110

fischer injektion system FIS V masonry

**Performances**  
Light-weight concrete hollow block Hbl, Characteristic resistance under shear load

**Annex C 94**

**Light-weight concrete solid block Vbl, EN 771-3**

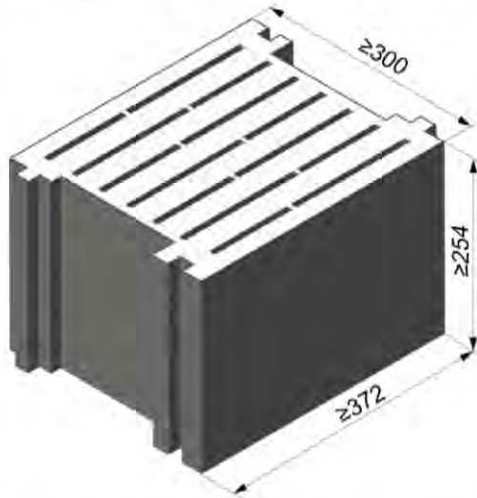

Light-weight concrete solid block Vbl, EN 771-3			
Producer	e.g. Sepa		
Nominal dimensions [mm]	length L	width W	height H
	≥ 372	≥ 300	≥ 254
Density $\rho$ [kg/dm <sup>3</sup> ]	≥ 0,6		
Compressive strength $f_b$ [N/mm <sup>2</sup> ]	2		
Standard or annex	EN 771-3		

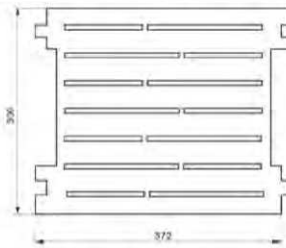

**Table C95.1:** Installation parameters

Anchor rod	M8	M10	M10	M12	M12	M16	M16	M12	M16	
Perforated sleeve FIS H K	16x130		18x130/200		20x130		22x130/200		20x200	
<b>Anchor rod with perforated sleeve FIS H K</b>										
Max. installation torque $T_{inst,max}$ [Nm]	4									
<b>General installation parameters</b>										
Edge distance $c_{min}$	130									
Spacing $s_{min}$	$s_{min} \parallel = s_{cr} \parallel$ [mm]		370							
	$s_{min} \perp = s_{cr} \perp$		250							
<b>Drilling method</b>										
Hammer drilling with hard metal hammer drill										

**Table C95.2:** Group factors

Anchor rod	M8	M10	M10	M12	M12	M16	M16	M12	M16	
Perforated sleeve FIS H K	16x130		18x130/200		20x130		22x130/200		20x200	
Group factors	$\alpha_{q,N} \parallel$		2							
	$\alpha_{q,V} \parallel$									
	$\alpha_{q,N} \perp$									
	$\alpha_{q,V} \perp$									

fischer injektion system FIS V masonry

**Performances**  
Light-weight concrete solid block Vbl, dimensions, installation parameters

**Annex C 95**

**Light-weight concrete solid block Vbl, EN 771-3**

**Table C96.1:** Characteristic resistance under tensile load

Anchor rod	M8	M10	M10	M12	M12	M16	M16	M12	M16
Perforated sleeve FIS H K	16x130		18x130/200		20x130		22x130/200		20x200
<b>Tensile load <math>N_{Rk}</math> [kN] depending on the compressive strength <math>f_b</math> (temperature range 50/80°C)</b>									
compressive strength $f_b$	use category								
2 N/mm <sup>2</sup>	w/w	w/d	2,0			2,5			3,0
	d/d		2,0			3,0			4,0

Factor for temperature range 72/120°C: 0,83

**Table C96.2:** Characteristic resistance under shear load

Anchor rod	M8	M10	M10	M12	M12	M16	M16	M12	M16	
Perforated sleeve FIS H K	16x130		18x130/200		20x130		22x130/200		20x200	
<b>Shear load <math>V_{Rk}</math> [kN] depending on the compressive strength <math>f_b</math> (temperature range 50/80°C and 72/120°C)</b>										
compressive strength $f_b$	use category									
2 N/mm <sup>2</sup>	w/w	w/d	4,5				6,5			
	d/d									

Factor for job site tests and displacements see annex C110

fischer injektion system FIS V masonry

**Performances**

Light-weight concrete solid block Vbl,  
Characteristic resistance under tensile and shear load

**Annex C 96**

**Light-weight concrete solid block Vbl, EN 771-3**

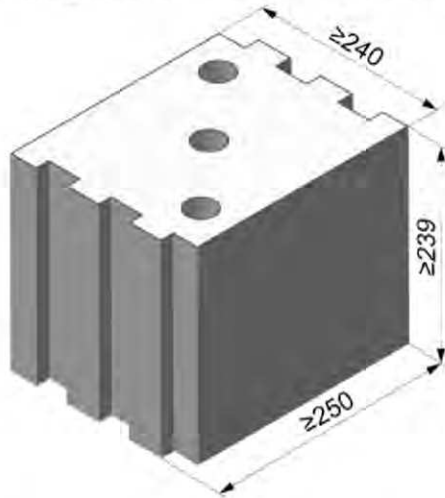

Light-weight concrete solid block Vbl, EN 771-3			
Producer	KLB		
Nominal dimensions [mm]	length L	width W	height H
	≥ 250	≥ 240	≥ 239
Density $\rho$ [kg/dm <sup>3</sup> ]	≥ 1,6		
Compressive strength $f_b$ [N/mm <sup>2</sup> ]	4 / 6 / 8		
Standard or annex	EN 771-3		

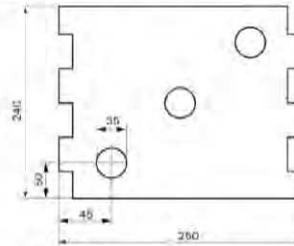

**Table C97.1:** Installation parameters  
(Pre-positioned anchorage with perforated sleeve FIS HK)

<b>Anchor rod</b>	M6	M8	M6	M8	-	M8	M10	M8	M10	-	M12	M16	M12	M16	M12	M16
<b>Internal threaded anchor FIS E</b>	-	-	M6	M8	11x85	-	-	M10	M12	15x85	-	-	-	-	-	-
<b>Perforated sleeve FIS H K</b>	12x50	12x85	16x85	16x130	20x85	20x130	20x200									
<b>Anchor rod and internal threaded anchor FIS E with perforated sleeve FIS H K</b>																
Max. installation torque $T_{inst,max}$ [Nm]	4															
<b>General installation parameters</b>																
Edge distance $c_{min}$	130															
Spacing $s_{min}$	$s_{min} \parallel = s_{cr} \parallel$															
	$s_{min} \perp = s_{cr} \perp$															
<b>Drilling method</b>																
Hammer drilling with hard metal hammer drill																

**Table C97.2:** Group factors

<b>Anchor rod</b>	M6	M8	M6	M8	-	M8	M10	M8	M10	-	M12	M16	M12	M16	M12	M16
<b>Internal threaded anchor FIS E</b>	-	-	M6	M8	11x85	-	-	M10	M12	15x85	-	-	-	-	-	-
<b>Perforated sleeve FIS H K</b>	12x50	12x85	16x85	16x130	20x85	20x130	20x200									
Group factors	$\alpha_{q,N} \parallel$	2,0														
	$\alpha_{q,V} \parallel$															
	$\alpha_{q,N} \perp$															
	$\alpha_{q,V} \perp$															

fischer injektion system FIS V masonry

**Performances**  
Light-weight concrete solid block Vbl, dimensions, installation parameters

**Annex C 97**



**Light-weight concrete solid block Vbl, EN 771-3****Table C98.1:** Installation parameters  
(Push through anchorage with perforated sleeve FIS HK)

Anchor rod	M10	M12	M16
Perforated sleeve FIS H K	18x130/200		22x130/200
<b>Anchor rod with perforated sleeve FIS H K</b>			
Max. installation torque $T_{inst,max}$ [Nm]	2		
<b>General installation parameters</b>			
Edge distance $c_{min}$	130		
Spacing $s_{min}$ [mm]	$s_{min} \parallel = s_{cr} \parallel$	250	
	$s_{min} \perp = s_{cr} \perp$	250	
<b>Drilling method</b>			
Hammer drilling with hard metal hammer drill			

**Table C98.2:** Group factors

Anchor rod	M10	M12	M16
Perforated sleeve FIS H K	18x130/200		22x130/200
Group factors $\alpha_{g,N} \parallel$ $\alpha_{g,V} \parallel$ $\alpha_{g,N} \perp$ $\alpha_{g,V} \perp$ [-]	2,0		

fischer injektion system FIS V masonry

**Performances**  
Light-weight concrete solid block Vbl, dimensions, installation parameters**Annex C 98**

**Light-weight concrete solid block Vbl, EN 771-3**

**Table C99.1:** Characteristic resistance under tensile load (Pre-positioned anchorage)

Anchor rod		M6	M8	M6	M8	-	M8	M10	M8	M10	-	M12	M16	M12	M16	M12	M16	
Internal threaded anchor FIS E		-		-		M6	M8	-		-		M10	M12	-		-		
Perforated sleeve FIS H K		12x50		12x85		16x85			16x130			20x85			20x130		20x200	
Tensile load $N_{Rk}$ [kN] depending on the compressive strength $f_b$ (temperature range 50/80°C)																		
compressive strength $f_b$		use category																
4 N/mm <sup>2</sup>	w/w	w/d	1,2	2,0	2,5						3,0							
	d/d		2,0	3,5	4,0						5,0							
6 N/mm <sup>2</sup>	w/w	w/d	1,5	3,0	4,0						5,0							
	d/d		3,0	5,0	6,5						7,5							
8 N/mm <sup>2</sup>	w/w	w/d	2,0	4,0	5,0						6,5							
	d/d		4,0	7,0	8,5						9,0							

**Table C99.2:** Characteristic resistance under tensile load (Push through anchorage)

Anchor rod		M10				M12				M16			
Perforated sleeve FIS H K		18x130/200								22x130/200			
Tensile load $N_{Rk}$ [kN] depending on the compressive strength $f_b$ (temperature range 50/80°C)													
compressive strength $f_b$		use category											
4 N/mm <sup>2</sup>	w/w	w/d	2,5						3,0				
	d/d		4,0						5,0				
6 N/mm <sup>2</sup>	w/w	w/d	4,0						5,0				
	d/d		6,5						7,5				
8 N/mm <sup>2</sup>	w/w	w/d	5,0						6,5				
	d/d		8,5						9,0				

Factor for job site tests and displacements see annex C110.

Factor for temperature range 72/120°C: 0,83

fischer injektion system FIS V masonry

**Performances**

Light-weight concrete solid block Vbl, Characteristic resistance under tensile load

**Annex C 99**

**Light-weight concrete solid block Vbl, EN 771-3**

**Table C100.1:** Characteristic resistance under shear load (Pre-positioned anchorage)

Anchor rod	M6	M8	M6	M8	-	M8	M10	M8	M10	-	M12	M16	M12	M16	M12	M16
Internal threaded anchor FIS E	-		-		M6	M8	-		-		M10	M12	-		-	
					11x85						15x85					
Perforated sleeve FIS H K	12x50		12x85		16x85			16x130		20x85			20x130		20x200	
<b>Shear load <math>V_{RK}</math> [kN] depending on the compressive strength <math>f_b</math> (temperature range 50/80°C and 72/120°C)</b>																
compressive strength $f_b$	use category															
4 N/mm <sup>2</sup>	w/w	w/d	2,0	3,0	2,0	3,0	2,0	3,5				4,5				
	d/d															
6 N/mm <sup>2</sup>	w/w	w/d	3,0	4,5	3,0	4,5	3,0	5,5				6,5				
	d/d															
8 N/mm <sup>2</sup>	w/w	w/d	4,0	6,0	4,0	6,0	4,0	7,0				8,5				
	d/d															

**Table C100.2:** Characteristic resistance under shear load (Push through anchorage)

Anchor rod	M10			M12			M16			
Perforated sleeve FIS H K	18x130/200						22x130/200			
<b>Shear load <math>V_{RK}</math> [kN] depending on the compressive strength <math>f_b</math> (temperature range 50/80°C and 72/120°C)</b>										
compressive strength $f_b$	use category									
4 N/mm <sup>2</sup>	w/w	w/d	3,5						4,5	
	d/d									
6 N/mm <sup>2</sup>	w/w	w/d	5,5						6,5	
	d/d									
8 N/mm <sup>2</sup>	w/w	w/d	7,0						8,5	
	d/d									

Factor for job site tests and displacements see annex C110.

fischer injektion system FIS V masonry

**Performances**

Light-weight concrete solid block Vbl, Characteristic resistance under shear load

**Annex C 100**

**Light-weight concrete solid block Vbl, EN 771-3**

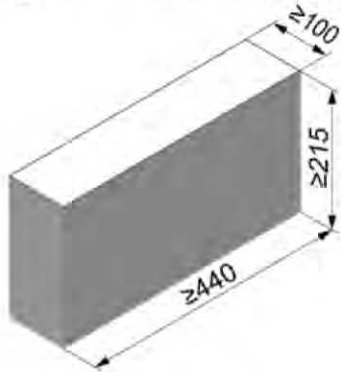

Light-weight concrete solid block Vbl, EN 771-3			
Producer	Roadstone wood		
Nominal dimensions [mm]	length L	width W	height H
	≥ 440	≥ 100	≥ 215
Density $\rho$ [kg/dm <sup>3</sup> ]	≥ 2,0		
Compressive strength $f_b$ [N/mm <sup>2</sup> ]	4 / 6 / 8 / 10		
Standard or annex	EN 771-3		

**Table C101.1:** Installation parameters

Anchor rod		M6	M8	M10	M12	M16
<b>Anchor rod without perforated sleeve</b>						
Effective anchorage depth $h_{ef}$ [mm]		50	70	50	70	50
Max. installation torque $T_{inst,max}$ [Nm]		4		10		
<b>General installation parameters</b>						
Edge distance $c_{min}$		100				
Spacing	$s_{min} \parallel$	75				
	$s_{cr} \parallel$	440				
	$s_{min} \perp$	75				
	$s_{cr} \perp$	215				
<b>Drilling method</b>						
Hammer drilling with hard metal hammer drill						

**Table C101.2:** Group factors

Anchor rod		M6	M8	M10	M12	M16
Group factors	$\alpha_{q,N} \parallel$	1,6				
	$\alpha_{q,V} \parallel$	1,3				
	$\alpha_{q,N} \perp$	1,4				
	$\alpha_{q,V} \perp$	1,3				

fischer injektion system FIS V masonry

**Performances**

Light-weight concrete solid block Vbl, dimensions, installation parameters

**Annex C 101**

**Light-weight concrete solid block Vbl, EN 771-3****Table C102.1:** Characteristic resistance under tensile load

Anchor rod		M6	M8	M10	M12	M16
<b>Tensile load <math>N_{Rk}</math> [kN] depending on the compressive strength <math>f_b</math> (temperature range 50/80°C)</b>						
compressive strength $f_b$	use category	Effective anchorage depth $h_{ef}$ [mm]				
		≥ 50				
4 N/mm <sup>2</sup>	w/w   w/d	1,2			1,2	
	d/d	2,0			2,0	
6 N/mm <sup>2</sup>	w/w   w/d	1,5			2,0	
	d/d	3,0			3,5	
8 N/mm <sup>2</sup>	w/w   w/d	2,0			2,5	
	d/d	4,0			4,5	
10N/mm <sup>2</sup>	w/w   w/d	3,0			3,5	
	d/d	5,0			5,5	

Factor for temperature range 72/120°C: 0,83

**Table C102.2:** Characteristic resistance under shear load

Anchor rod		M6	M8	M10	M12	M16
<b>Shear load <math>V_{Rk}</math> [kN] depending on the compressive strength <math>f_b</math> (temperature range 50/80°C and 72/120°C)</b>						
compressive strength $f_b$	use category	Effective anchorage depth $h_{ef}$ [mm]				
		≥ 50				
4 N/mm <sup>2</sup>	w/w   w/d	1,2	1,5	1,5	1,5	1,5
	d/d					
6 N/mm <sup>2</sup>	w/w   w/d	2,0	2,0	2,5	2,5	2,5
	d/d					
8 N/mm <sup>2</sup>	w/w   w/d	2,5	2,5	3,0	3,0	3,5
	d/d					
10N/mm <sup>2</sup>	w/w   w/d	3,0	3,5	4,0	4,0	4,5
	d/d					

Factor for job site tests and displacements see annex C110

fischer injektion system FIS V masonry

**Performances**Light-weight concrete solid block Vbl,  
Characteristic resistance under tensile and shear load**Annex C 102**

**Light-weight concrete solid block Vbl, EN 771-3**

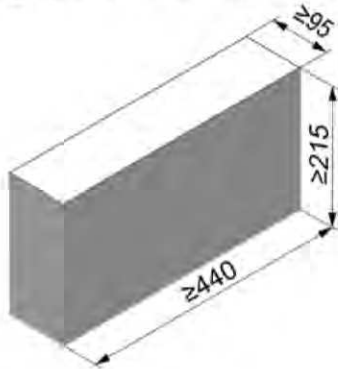

Light-weight concrete solid block Vbl, EN 771-3			
Producer	Tramac		
Nominal dimensions [mm]	length L	width W	height H
	≥ 440	≥ 95	≥ 215
Density $\rho$ [kg/dm <sup>3</sup> ]	≥ 2,0		
Compressive strength $f_b$ [N/mm <sup>2</sup> ]	6 / 8 / 10 / 12		
Standard or annex	EN 771-3		

**Table C103.1:** Installation parameters

Anchor rod		M6		M8		M10		M12		M16		
<b>Anchor rod without perforated sleeve</b>												
Effective anchorage depth	$h_{ef}$	[mm]	50	70	50	70	50	70	50	70	50	70
Max. installation torque	$T_{inst,max}$	[Nm]	4		10							
<b>General installation parameters</b>												
Edge distance	$c_{min}$		60									
Spacing	$s_{min} \parallel$	[mm]	75									
	$s_{cr} \parallel$		440									
	$s_{min} \perp$		75									
	$s_{cr} \perp$		215									
	<b>Drilling method</b>											
Hammer drilling with hard metal hammer drill												

**Table C103.2:** Group factors

Anchor rod		M6		M8		M10		M12		M16	
Group factors	$\alpha_{g,N} \parallel$	[-]	1,9								
	$\alpha_{g,V} \parallel$		1,4								
	$\alpha_{g,N} \perp$		1,9								
	$\alpha_{g,V} \perp$		1,4								

fischer injektion system FIS V masonry

**Performances**

Light-weight concrete solid block Vbl, dimensions, installation parameters

**Annex C 103**

**Light-weight concrete solid block Vbl, EN 771-3**

**Table C104.1:** Characteristic resistance under tensile load

Anchor rod		M6		M8		M10		M12		M16		
Tensile load $N_{Rk}$ [kN] depending on the compressive strength $f_b$ (temperature range 50/80°C)												
compressive strength $f_b$	use category		Effective anchorage depth $h_{ef}$ [mm]									
	w/w	w/d	50	70	50	70	50	70	50	70	50	70
6 N/mm <sup>2</sup>	w/w	w/d	1,5	2,0	1,5	2,0	1,5	2,0	1,5	2,0	1,5	2,0
	d/d		2,5	3,5	2,5	3,5	2,5	3,5	2,5	3,5	2,5	3,5
8 N/mm <sup>2</sup>	w/w	w/d	2,0	2,5	2,0	2,5	2,0	3,0	2,0	3,0	2,0	3,0
	d/d		3,5	4,5	3,5	4,5	3,5	5,0	3,5	5,0	3,5	5,0
10N/mm <sup>2</sup>	w/w	w/d	2,5	3,5	2,5	3,5	2,5	3,5	2,5	3,5	2,5	3,5
	d/d		4,5	6,0	4,5	6,0	4,5	6,0	4,5	6,0	4,5	6,0
12N/mm <sup>2</sup>	w/w	w/d	3,0	4,0	3,0	4,0	3,0	4,5	3,0	4,5	3,0	4,5
	d/d		5,0	7,0	5,0	7,0	5,0	7,5	5,0	7,5	5,0	7,5

Factor for temperature range 72/120°C: 0,83

**Table C104.2:** Characteristic resistance under shear load

Anchor rod		M6		M8		M10		M12		M16		
Shear load $V_{Rk}$ [kN] depending on the compressive strength $f_b$ (temperature range 50/80°C and 72/120°C)												
compressive strength $f_b$	use category		Effective anchorage depth $h_{ef}$ [mm]									
	w/w	w/d	≥ 50									
6 N/mm <sup>2</sup>	w/w	w/d	2,0		2,0		2,0		1,5		1,5	
	d/d		2,0		2,0		2,0		1,5		1,5	
8 N/mm <sup>2</sup>	w/w	w/d	2,5		2,5		3,0		2,5		2,5	
	d/d		2,5		2,5		3,0		2,5		2,5	
10N/mm <sup>2</sup>	w/w	w/d	3,5		3,5		4,0		3,0		3,0	
	d/d		3,5		3,5		4,0		3,0		3,0	
12N/mm <sup>2</sup>	w/w	w/d	4,0		4,0		4,5		3,5		3,5	
	d/d		4,0		4,0		4,5		3,5		3,5	

Factor for job site tests and displacements see annex C110

fischer injektion system FIS V masonry

**Performances**

Light-weight concrete solid block Vbl,  
Characteristic resistance under tensile and shear load

**Annex C 104**

**Autoclaved aerated concrete (cylindrical drill hole), EN 771-4**



Autoclaved aerated concrete, EN 771-4			
Producer	e.g. Ytong		
Density $\rho$ [kg/dm <sup>3</sup> ]	0,35	0,5	0,65
Compressive strength $f_b$ [N/mm <sup>2</sup> ]	2	4	6
Standard or annex	EN 771-4		

**Table C105.1:** Installation parameters

Anchor rod	M6	M8	M10	M12	M16	-		-	
Internal threaded anchor FIS E	-	-	-	-		M6	M8	M10	M12
	11x85		15x85						
<b>Anchor rod and internal threaded anchor FIS E without perforated sleeve</b>									
Effective anchorage depth $h_{ef}$ [mm]	100	200	100	200	100	200	100	200	85
Max. installation torque $T_{inst,max}$ [Nm]	1	4	1	8	2	12	2	16	2
<b>General installation parameters</b>									
Edge distance $c_{min}$	100								
Spacing	$s_{cr \parallel} = s_{min \parallel}$	250							
	$h_{ef}=200mm$	80							
	$s_{cr \perp} = s_{min \perp}$	250							
	$h_{ef}=200mm$	80							
	$s_{cr \perp} = s_{min \perp}$	80							
<b>Drilling method</b>									
Hammer drilling with hard metal hammer drill									
fischer injektion system FIS V masonry								<b>Annex C 105</b>	
<b>Performances</b>		Autoclaved aerated concrete (cylindrical drill hole), dimensions, installation parameters							



**Table C106.1:** Group factors for autoclaved aerated concrete  
(Compressive strength  $f_b = 2 \text{ N/mm}^2$ )

Anchor rod	M6	M8	M10	M12	M16	-		-		
Internal threaded anchor FIS E	-	-	-	-	-	M6	M8	M10	M12	
						11x85		15x85		
Group factors	$h_{ef}=200 \alpha_{q,N} \parallel$	[-]	1,6			-	-			
	$h_{ef}=200 \alpha_{q,V} \parallel$		1,1			-	-			
	$\alpha_{q,N} \parallel, \alpha_{q,V} \parallel$		2							
	$h_{ef}=200 \alpha_{q,N} \perp$		1,6			-	-			
	$h_{ef}=200 \alpha_{q,V} \perp$		0,8			-	-			
	$\alpha_{q,N} \perp, \alpha_{q,V} \perp$		2							

**Table C106.2:** Group factors for autoclaved aerated concrete  
(Compressive strength  $f_b = 4 \text{ N/mm}^2$ )

Anchor rod	M6	M8	M10	M12	M16	-		-		
Internal threaded anchor FIS E	-	-	-	-	-	M6	M8	M10	M12	
						11x85		15x85		
Group factors	$h_{ef}=200 \alpha_{q,N} \parallel$	[-]	0,7			-	-			
	$h_{ef}=200 \alpha_{q,V} \parallel$		2,0			-	-			
	$\alpha_{q,N} \parallel, \alpha_{q,V} \parallel$		2							
	$h_{ef}=200 \alpha_{q,N} \perp$		0,7			-	-			
	$h_{ef}=200 \alpha_{q,V} \perp$		1,2			-	-			
	$\alpha_{q,N} \perp, \alpha_{q,V} \perp$		2							

**Table C106.3:** Group factors for autoclaved aerated concrete  
(Compressive strength  $f_b = 6 \text{ N/mm}^2$ )

Anchor rod	M6	M8	M10	M12	M16	-		-		
Internal threaded anchor FIS E	-	-	-	-	-	M6	M8	M10	M12	
						11x85		15x85		
Group factors	$h_{ef}=200 \alpha_{q,N} \parallel$	[-]	0,7			-	-			
	$h_{ef}=200 \alpha_{q,V} \parallel$		2,0			-	-			
	$\alpha_{q,N} \parallel, \alpha_{q,V} \parallel$		2							
	$h_{ef}=200 \alpha_{q,N} \perp$		0,7			-	-			
	$h_{ef}=200 \alpha_{q,V} \perp$		1,2			-	-			
	$\alpha_{q,N} \perp, \alpha_{q,V} \perp$		2							

fischer injektion system FIS V masonry	<b>Annex C 106</b>
<b>Performances</b> Autoclaved aerated concrete (cylindrical drill hole), Group factors	

**Autoclaved aerated concrete (cylindrical drill hole), EN 771-4**

**Table C107.1:** Characteristic resistance under tensile load

Anchor rod		M6		M8		M10		M12		M16		-		-	
Internal threaded anchor FIS E		-		-		-		-		-		M6	M8	M10	M12
												11x85		15x85	
Tensile load $N_{Rk}$ [kN] depending on the compressive strength $f_b$ (temperature range 50/80°C)															
compressive strength $f_b$	use category	Effective anchorage depth $h_{ef}$ [mm]													
		100	200	100	200	100	200	100	200	100	200	100	200	85	
2 N/mm <sup>2</sup>	w/w	w/d	1,2	1,2	1,5	2,0	1,5	3,0	1,5	3,0	2,0	3,0	1,5	1,5	
	d/d		1,5	3,0	1,5	3,0	1,5	3,5	2,0	4,0	2,0	4,0	1,5	1,5	
4 N/mm <sup>2</sup>	w/w	w/d	1,2	-	2,0	1,5	2,5	3,5	2,5	3,5	2,0	3,5	2,0	1,5	
	d/d		1,5	-	2,0	3,0	3,0	5,0	2,5	5,0	2,0	5,0	2,0	1,5	
6 N/mm <sup>2</sup>	w/w	w/d	1,5	-	3,0	2,5	4,5	5,0	4,5	7,0	3,0	8,5	3,5	2,5	
	d/d		1,5	-	3,5	4,0	5,0	7,0	5,0	9,0	3,0	11,5	3,5	2,5	

Factor for temperature range 72/120°C: 0,83

**Table C107.2:** Characteristic resistance under shear load

Anchor rod		M6		M8		M10		M12		M16		-		-	
Internal threaded anchor FIS E		-		-		-		-		-		M6	M8	M10	M12
												11x85		15x85	
Shear load $V_{Rk}$ [kN] depending on the compressive strength $f_b$ (temperature range 50/80°C and 72/120°C)															
compressive strength $f_b$	use category	Effective anchorage depth $h_{ef}$ [mm]													
		100	200	100	200	100	200	100	200	100	200	100	200	85	
2 N/mm <sup>2</sup>	w/w	w/d	1,2	1,2	1,2	1,2	1,2	1,2	1,5	1,2	1,2	1,2	1,2	1,2	1,5
	d/d		1,2	1,2	1,2	1,2	1,2	1,2	1,5	1,2	1,2	1,2	1,2	1,2	1,5
4 N/mm <sup>2</sup>	w/w	w/d	2,0	-	2,5	2,0	2,0	2,0	2,5	2,0	2,0	2,0	2,0	2,0	2,5
	d/d		2,0	-	2,5	2,0	2,0	2,0	2,5	2,0	2,0	2,0	2,0	2,0	2,5
6 N/mm <sup>2</sup>	w/w	w/d	2,5	-	3,0	2,5	3,0	3,0	3,5	4,0	4,5	4,5	2,5	3,5	
	d/d		2,5	-	3,0	2,5	3,0	3,0	3,5	4,0	4,5	4,5	2,5	3,5	

Factor for job site tests and displacements see annex C110

fischer injektion system FIS V masonry

**Performances**

Autoclaved aerated concrete (cylindrical drill hole),  
Characteristic resistance under tensile and shear load

**Annex C 107**

**Autoclaved aerated concrete (conical drill hole with special drill bit PBB), EN 771-4**



Autoclaved aerated concrete, EN 771-4			
Producer	e.g. Ytong		
Density $\rho$ [kg/dm <sup>3</sup> ]	0,35	0,5	0,65
Compressive strength $f_b$ [N/mm <sup>2</sup> ]	2	4	6
Standard or annex	EN 771-4		

**Table C108.1:** Installation parameters

Anchor rod	M8		M10		M12		-		
Internal threaded anchor FIS E	-	-	-	-	-	-	M6	M8	
Anchor rod and internal threaded anchor FIS E without perforated sleeve									
Effective anchorage depth $h_{ef}$ [mm]	75	95	75	95	75	95	85		
Max. installation torque $T_{Inst,max}$ [Nm]	2								
<b>General installation parameters</b>									
Edge distance $c_{min}$	120	150	120	150	120	150	150		
Spacing	$s_{cr \parallel} = s_{min \parallel}$ [mm]	240	300	240	300	240	300	300	
	$s_{cr \perp} = s_{min \perp}$	240	250	240	250	240	250	250	
<b>Drilling method</b>									
Hammer drilling with hard metal hammer drill									

**Table C108.2:** Group factors

Anchor rod	M8		M10		M12		-	
Internal threaded anchor FIS E	-	-	-	-	-	-	M6	M8
Anchor rod and internal threaded anchor FIS E without perforated sleeve								
Group factors	$\alpha_{q,N \parallel}$	[-]	2					
	$\alpha_{q,V \parallel}$							
	$\alpha_{q,N \perp}$							
	$\alpha_{q,V \perp}$							

fischer injektion system FIS V masonry

**Performances**

Autoclaved aerated concrete (conical drill hole with special drill bit PBB), dimensions, installation parameters

**Annex C 108**

**Autoclaved aerated concrete (conical drill hole with special drill bit PBB), EN 771-4****Table C109.1:** Characteristic resistance under tensile load

Anchor rod		M8		M10		M12		-	
Internal threaded anchor FIS E		-	-	-	-	-	-	M6	M8
		11x85							
<b>Tensile load <math>N_{Rk}</math> [kN] depending on the compressive strength <math>f_b</math> (temperature range 50/80°C)</b>									
compressive strength $f_b$	use category	Effective anchorage depth $h_{ef}$ [mm]							
		75	95	75	95	75	95	85	
2 N/mm <sup>2</sup>	w/w	2,0	2,5	2,0	2,5	2,0	2,5	2,0	2,0
	d/d	2,0	2,5	2,0	2,5	2,0	2,5	2,0	2,0
4 N/mm <sup>2</sup>	w/w	3,0	3,5	3,0	3,5	3,0	3,5	3,0	3,0
	d/d	3,0	3,5	3,0	3,5	3,0	3,5	3,0	3,0
6 N/mm <sup>2</sup>	w/w	3,5	4,0	3,5	4,0	3,5	4,0	3,5	3,5
	d/d	4,0	4,5	4,0	4,5	4,0	4,5	4,0	4,0

Factor for temperature range 72/120°C: 0,83

**Table C109.2:** Characteristic resistance under shear load

Anchor rod		M8		M10		M12		-	
Internal threaded anchor FIS E		-	-	-	-	-	-	M6	M8
		11x85							
<b>Shear load <math>V_{Rk}</math> [kN] depending on the compressive strength <math>f_b</math> (temperature range 50/80°C and 72/120°C)</b>									
compressive strength $f_b$	use category	Effective anchorage depth $h_{ef}$ [mm]							
		75	95	75	95	75	95	85	
2 N/mm <sup>2</sup>	w/w	2,5							
	d/d								
4 N/mm <sup>2</sup>	w/w	4,5							
	d/d								
6 N/mm <sup>2</sup>	w/w	6,0							
	d/d								

Factor for job site tests and displacements see annex C110

fischer injektion system FIS V masonry

**Performances**Autoclaved aerated concrete (conical drill hole with special drill bit PBB),  
Characteristic resistance under tensile and shear load**Annex C 109**

**β-factors for job site tests; displacements**

**Table C110.1:** β-factors for job site tests

use category		w/w and w/d		d/d	
temperature range		50/80	72/120	50/80	72/120
Material	Size				
solid units	M6	0,55	0,46	0,96	0,80
	M8	0,57	0,51		
	M10	0,59	0,52		
	M12 FIS E 11x85	0,6	0,54		
	M16 FIS E 15x85	0,62	0,52		
	16x85	0,55	0,46		
hollow units	all sizes	0,86	0,72	0,96	0,8
Autoclaved aerated concrete cylindrical drill hole	all sizes	0,73	0,73	0,81	0,81
Autoclaved aerated concrete conical drill hole	all sizes	0,66	0,59	0,73	0,66

**Table C110.2:** Displacements

Material	N [kN]	δN <sub>0</sub> [mm]	δN <sub>∞</sub> [mm]	V [kN]	δV <sub>0</sub> [mm]	δV <sub>∞</sub> [mm]
solid units and autoclaved aerated concrete h <sub>ef</sub> =100m	$\frac{N_{Rk}}{1,4 * \gamma_{Mm}}$	0,03	0,06	$\frac{V_{Rk}}{1,4 * \gamma_{Mm}}$	0,82	0,88
hollow units	$\frac{N_{Rk}}{1,4 * \gamma_{Mm}}$	0,48	0,06	$\frac{V_{Rk}}{1,4 * \gamma_{Mm}}$	1,71	2,56
solid brick Mz NF annex C 4 - C 7	$\frac{N_{Rk}}{1,4 * \gamma_{Mm}}$	0,74	1,48	$\frac{V_{Rk}}{1,4 * \gamma_{Mm}}$	1,23	1,85
solid brick Ks NF annex C 14 / C 15	$\frac{N_{Rk}}{1,4 * \gamma_{Mm}}$	0,2	0,4	$\frac{V_{Rk}}{1,4 * \gamma_{Mm}}$	0,91	1,37
AAC h <sub>ef</sub> =200 mm annex C 105 - C 107	$\frac{N_{Rk}}{1,4 * \gamma_{Mm}}$	1,03	2,06	$\frac{V_{Rk}}{1,4 * \gamma_{Mm}}$	1,25	1,88
brick Annex C 89 / C 90	$\frac{N_{Rk}}{1,4 * \gamma_{Mm}}$	0,03	0,06	$\frac{V_{Rk}}{1,4 * \gamma_{Mm}}$	6,44	9,66

For anchorage in autoclaved aerated concrete, the partial safety factor  $\gamma_{MAAC}$  shall be used instead of  $\gamma_{Mm}$ .

fischer injektion system FIS V masonry

**Performances**  
β-factors for job site tests; displacements

**Annex C 110**